

1 Dedusting Technology

1.1 Silo Filter PNEUFIX

- 1.1.1 PNEUFIX 20-24
- 1.1.2 PNEUFIX 30-48

1.2 Silo Filter STAFI

1.3 Mixer Filter MIXFI

1.4 Loader Filter BELFI

1.5 Conveyor and Loader Filter ULUFI

1.6 Transfer filter Stafi R

1.7 Cement Scale filter ZEWAfi

2 Silo Safety

2.1 Overpressure Vacuumflap SDAK

2.2 Overfill Protection

- 2.2.1 NW 80, 100, 125, 150

2.3 Level Indicators

- 2.3.1 Max
- 2.3.2 Min

3 Discharge Aids

3.1 Pneumatical LUALO

- 3.1.1 Air Jet Loosening System
- 3.1.2 Cushion Air Loosening System
- 3.1.3 Air Injector Loosening System

3.2 Mechanical ASK / SVA

- 3.2.1 Discharge Vibrating Cage ASK 1xxx
- 3.2.2 Vibrating Boom SVA
- 3.2.3 Discharge and dosing system

4 Shutoff Components

4.1 Butterfly Valves

- 4.1.1 Butterfly Valves F1
- 4.1.2 Butterfly Valves F2

4.2 Modular Flat Gate Valves SMFS

- 4.2.1 SMFS-H hand driven
- 4.2.2 SMFS-P pneumatically driven
- 4.2.3 SMFS-GM electromotor driven
- 4.2.4 SMFS Coarse Grain

4.3 Round Gate Valves SMRS-H / -P

4.4 Segment Lock Type SPS-EP electro-pneumatic

5 Loading Spouts

5.1 Silo Vehicle Loaders

- 5.1.1 JBM 220 QUADRO
- 5.1.2 JBM 200 TELE-RONDO

5.2 Open Truck Silo Vehicle Loaders

5.2.1 RONDO 250

- 5.2.1.1 JBM 250 RONDO hand
- 5.2.1.2 JBM 250 RONDO motor

- Silo Vehicles
- Open Road and Railway Vehicles
- Combined Version Silo Vehicles and Open Road Vehicles

- 5.2.1.3 JBM 300 RONDO 300 M

5.2.2 Gravel Loader RONDO 350 500

5.2.3 Gravel Loader RONDO 600 800

5.3 Stockpile Loader JBM 350 H

5.4 Ship Loader JBM 500

5.5 Docking Device NW 200

5.6 Positioners Longitudinal and

Cross Traversing Unit QLV 400 / LV 400

- 5.6.1 Longitudinal and Cross Traversing Unit QLV 400

- 5.6.2 Longitudinal Traverse Unit LV 400

6 Filling

6.1 Flow-Bow®

6.2 Filling Pipes

6.2.1 Filling Pipes galvanized

6.2.2 Filling Pipes Fixing

- 6.2.2.1 Clamps
- 6.2.2.2 Brackets

6.3 CONNEX Pipe Coupling

6.4 Two Way Valve ZR

6.5 Pinch Valve SQV

6.6 Additional Nozzle

6.7 Insert Bow

7 Conveyors / Dosages

7.1 Pipe Screw Conveyors

7.2 Rotary Valve

8 BIG-BAG

8.1 Mobile BIG-BAG Filling Station SBB 1000 M

8.2 Bagemptying Station SSA-10

9 Silos

9.1 Cement Silos

10 Miscellaneous

Brochures

PRESSURE DIFFERENCE ACTUATED FULLY AUTOMATIC ELECTRO-PNEUMATIC FILTER

WITH WEATHER HOOD WITHOUT FAN



The filter is used for dedusting silos and bunkers which are pneumatically loaded.

Areas of Application

- Installation-friendly filter box
- Easy to open weather hood with integrated dedusting system. This allows easy access to the filter cartridges, **as well as a tool-free exchange of the filter cartridges.**
- The filter cartridges with high-quality, star-shaped folded polyester non-woven material lining, ensure lower rest dust concentration.
- Fully electronic preset, differential pressure controlled automatic cleaning system.
- Besides free selectable clearance times through full-electronic filter control, the pressure difference actuated dedusting automatic is installed on the filter box, **factory-set wired and programmed.**

Details / Explanation

- Rust removal: SA 2,5
- Primer: 2K; 40µm
- Top coat: 2K; RAL 9006; 40µm

Finish



Easy to open weather hood

Tool-free exchange of filter cartridges

The engaging frequency of the dedusting automatic depends on the dust setting of the exhaust air, as well as the consistence of the medium.

Notice



SCHEME OF STREAMING

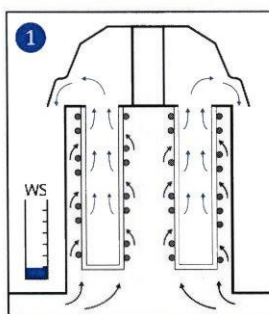

1 Dust loaded air streams through the filter cartridge. The dust particles displace on the outer surface of the filter cartridges. Through the open top cartridges the clean medium can exhaust.

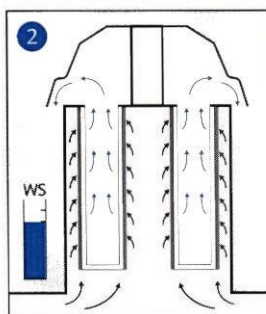

2 With increasing dust deposit, the filter resistance increases. As the set-up differential pressure is reached, the cleaning cycle begins automatically.

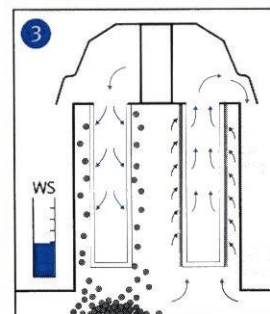

3 Undisturbed continuous operation is ensured by the single cleaning of filter elements. The dust falls back into the silo. At a under usage of a minimum-filter resistance, the cleaning cycle turns off automatically.

Dimensions top filter

Filter system	20	24
A without fan mm	1500	1700
B without fan mm	970	
C mm	630	
G mm	1030	
X mm free space cartridge filters	2000	2400

Dimensions connecting flange

Filter system	20	24
Outside \varnothing mm	900	
Inside \varnothing mm	800	
Hole circle mm	860	
Number of holes / \varnothing mm	8 x \varnothing 14	

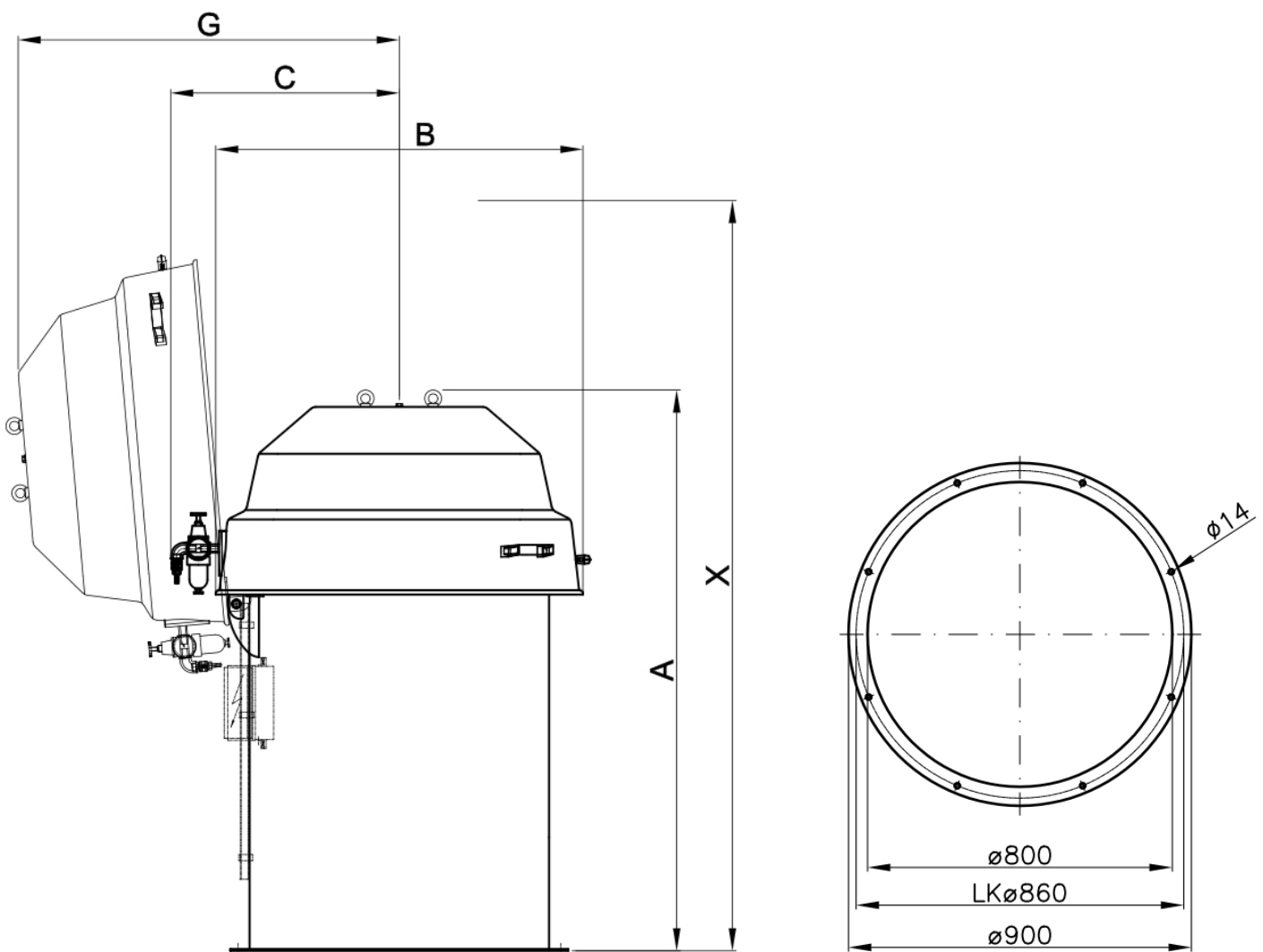

Technical data filter

Filter system	20	24
Capacity, Nm ³ /h	1000	1200
Maximum temperature	130°C / optional 150°C	
Filter cartridges, pc.	4	
Filter medium	polyester	
Solenoid valves, pc.	4	
Operating pressure	2,5 bar	
Air connection, mm	ø 13	
Actuation air	75 Nltr / min. with a break time of 20 sec.	
Weight, kg	140	155

Article number

Filter system	20	24
	Article number	Article number
Without fan	722 10 342	722 10 343
Without fan ATEX 20 / 22	722 10 359	722 10 360
Without fan stainless steel VA	722 10 208	722 10 300

WITH WEATHER HOOD AND FAN

Filter with fan

Filter without fan with exhaust air pipe

The filter is used for dedusting silos and bunkers which are pneumatically loaded.

- Installation-friendly filter box
- Easy to open weather hood with integrated dedusting system. This allows easy access to the filter cartridges, **as well as a tool-free exchange of the filter cartridges.**
- The filter cartridges with high-quality, star-shaped folded polyester non-woven material lining, ensure lower rest dust concentration.
- Fully electronic preset automatic differential pressure controlled automatic cleaning system
- Filter control mounted on the filter housing, wired and programmed
- The powerful fan is mounted on a console on the side of the filter housing. As a result, the position of the fan remains unchanged when the filter housing is opened. On the exhaust side there is an air outlet arch for rain protection and a bird protection grille.

- Rust removal: SA 2,5
Primer: 2K; 40µm
Top coat: 2K; RAL 9006; 40µm

Areas of Application**Details / Explanation****Finish**

Dimensions filter

Filter system	20	24
A without fan mm	1350	1550
B without fan mm	995	
C mm	435	
D mm	1450	1650
G mm	995	
X mm free space cartridge filters	2200	2400

Dimensions connecting flange

Filter system	20	24
Outside ø mm	900	
Inside ø mm	800	
Hole circle mm	860	
Number of holes, ø mm	8 x ø 14	

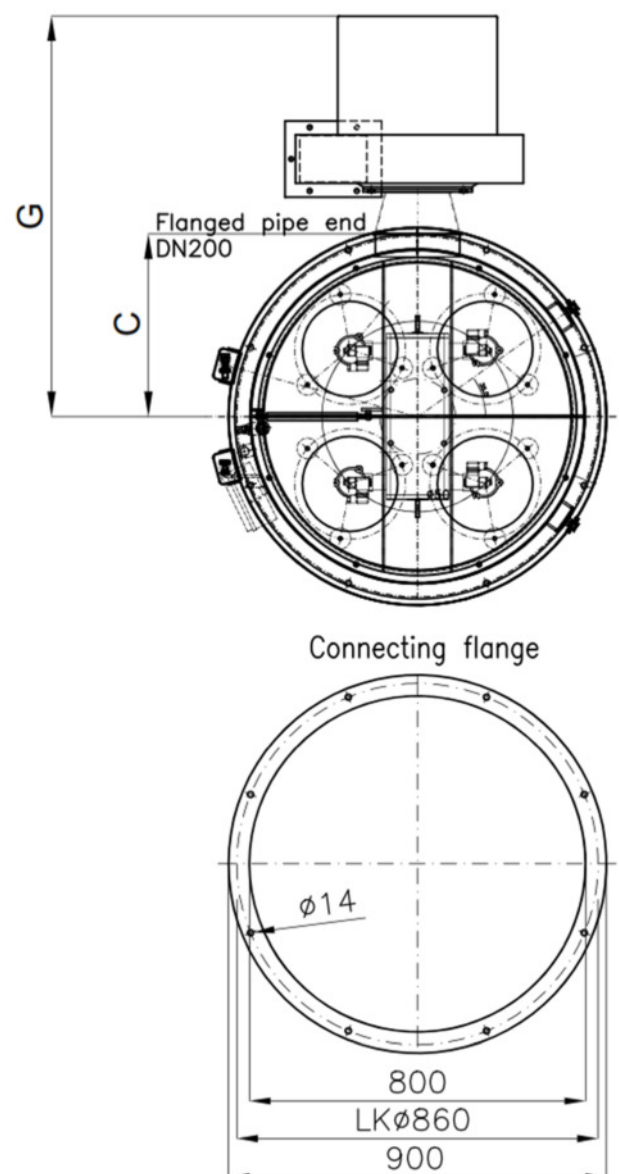
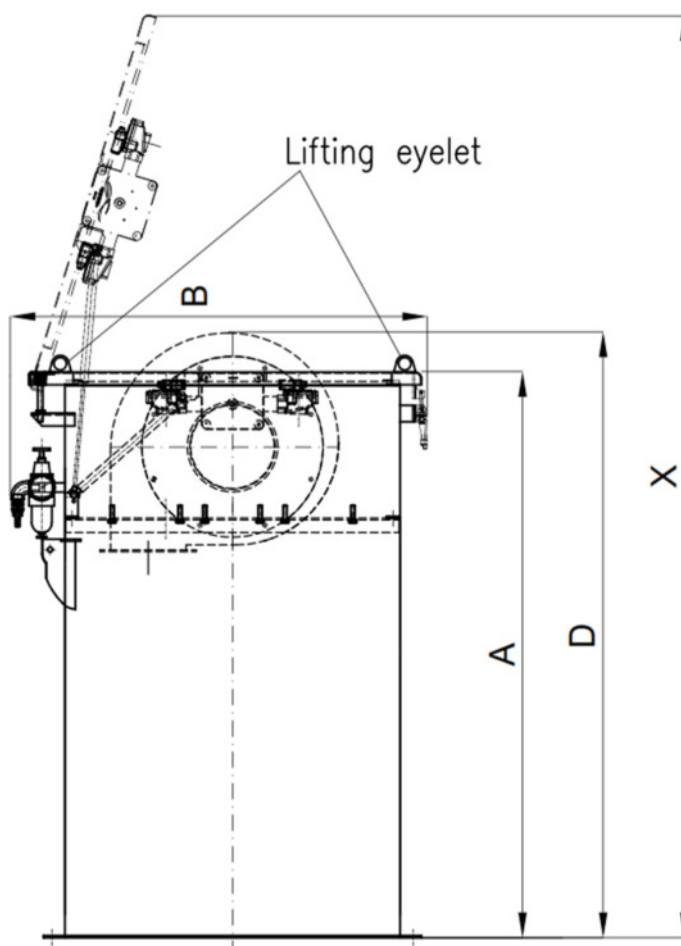

Technical data filter

Filter system	20	24
Capacity, Nm ³ / h	1000	1200
Maximum temperature	130°C / optional 150°C	
Filter cartridges, pc.	4	
Filter medium	polyester	
Solenoid valves, pc.	4	
Operating pressure	2,5 bar	
Compressed air connection, mm	ø 13	
Compressed air demand, Nltr / min	75 Nltr / min. with a break time of 20 sec.	
Weight, kg	180	195



Technical data fan

Filter system	20	24
Fan power, kW	0,55	1,1
Motor voltage	230 V / 400 V / 50 Hz	
Static pressure rise, Pa	approx. 2200	approx. 2400
Volume flow, m ³ / h	max. 1140	max. 1500

Article number

Filter system	20	24
	Article number	Article number
Without fan	722 10 347	722 10 348
Without fan ATEX 20 / 22	722 10 359	722 10 292
Without fan product contact stainless steel VA	722 10 390	722 10 391
With air vents NW 200 beading	722 10 224	722 10 392
Other versions on request		

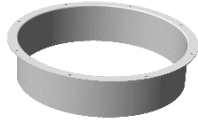
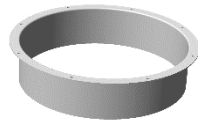
Equipment / Spare parts

Filter system	20	24	
	Article number	Article number	
Welded frame primed	722 10 130	722 10 130	
Welded frame stainless steel VA 1.4301	722 10 162	722 10 162	
Filter cartridge SLP standard	722 10 001	722 10 158	

Filter system	20	24	
	Article number	Article number	
Filter cartridge SLP antistatic ATEX 	722 10 087	722 10 057	
Filter cartridge SLP by 150°C	722 10 218	722 10 183	
Inspection flap - spare -	STO581	STO581	
Control system DP4 for pneumatic filters, connection voltage 230 V/AC for 4 magnet valves 24V/DC	881 10 209	881 10 209	
Control system DP4 for pneumatic filters, connection voltage 24 V/DC for 4 magnet valves 24V/DC	881 10 209-24V	881 10 209-24V	
Control system DP4 for pneumatic filters, connection voltage 230 V/AC ATEX zone 22 for 4 pneumatic valves	881 10 210	881 10 210	
Control system DP4 for pneumatic filters, connection voltage 24 V/DC ATEX zone 22 for 4 pneumatic valves 	881 10 210-24V	881 10 210-24V	
Valve cover set without coil ATEX / 881 10 210 	881 10 268	881 10 268	
Valve cover set 24V/DC, consisting of diaphragm, coil, cover	881 10 245	881 10 245	
Valve cover set 230 V/AC, consisting of diaphragm, coil, cover	881 10 247	881 10 247	

Diaphragm for quick relief valve	881 10 246	881 10 246	
Magnetic valve coil, 24V/DC	881 10 245-01	881 10 245-01	
Magnetic valve coil, 230V/AC	881 10 247-01	881 10 247-01	
Valve cover	881 10 253	881 10 253	
Valve connector Typ BI, cables 2m	881 10 401	881 10 401	
Filter regulator G 1/2"	874 10 001	874 10 001	
Magnetic valve complete, 24V/AC / 24V/DC old filter version (up to year of construction. 2013)	on request	on request	

Additional sizes and options (e.g. pressure surge protect construction) can be tailored to your special application!

When placing an order please define the materials which are stored in your silo (e.g. cement, lime etc...)

PRESSURE DIFFERENCE ACTUATED FULLY AUTOMATIC ELECTRO-PNEUMATIC FILTER



The filter is used for dedusting silos and bunkers which are pneumatically loaded.

- Installation-friendly filter box made out of coated steel plate.
- Galvanised, easy to open weather hood. This guarantees tool-free access to the filter cartridges at any time
- The filter cartridges with high-quality, star-shaped folded polyester non-woven material lining and plastic bottom ensure lower concentration of residual dust concentration. The installation is carried out clean gas-sided.
- The quick release outlets together with the blast pipes are directly installed on the pressure reservoir in the cap. Thus short ways of the dedusting air are created. This reduces the consumption of compressed air and results in an optimal cleaning of the filter cartridges.
- The powerful ventilator is installed on a console next to the filter box. Therefore, the ventilator doesn't change its position when opening the filter box. A blow out arch, functioning as a rain protection, as well as a bird protection grid, are installed at the air exhaust side of the box
- In order to protect the solenoid valves and the filter cartridges a pressure reduction / compressed-air service unit with 25 micrometer filter is installed upstream
- Besides free selectable clearance times through full-electronic filter control, the pressure difference actuated dedusting automatic is installed on the filter box, **factory-set wired and programmed.**

- Rust removal: SA 2,5
Primer: 2K; 40µm
Top coat: 2K; RAL 9006; 40µm

The switch frequency of the dedusting automatic depends on the dust consistence of the exhaust air, as well as the consistence of the medium.

Dimensions Top Filter

Filter area m ²	30	36	42	48
A without / with ventilator	1640 / on the side			
B without / with ventilator	Ø 1200			
C mm	870	900	900	900
D mm	1150			
F mm	approx. 2600			
G mm	920			
Y cartridges extending into	-	200	200	400
S	Ø 14			

Dimensions Connection Flange

Filter area m ²	30	36	42	48
Outside ø mm	1200			
Inside ø mm	1100			
Hole circle mm	1050			
Number of holes / ø mm	12 x Ø 14			

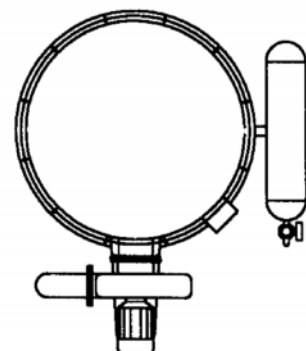
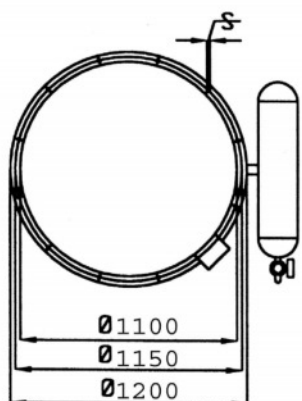
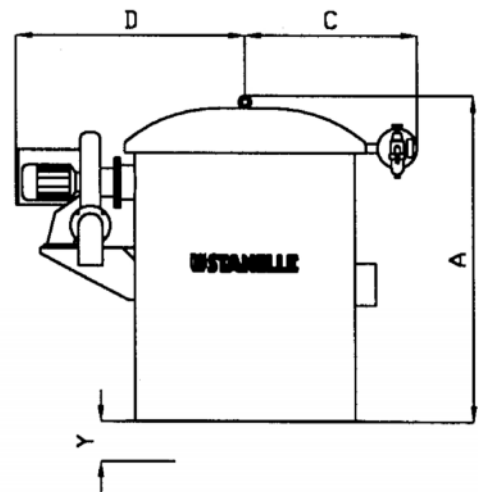
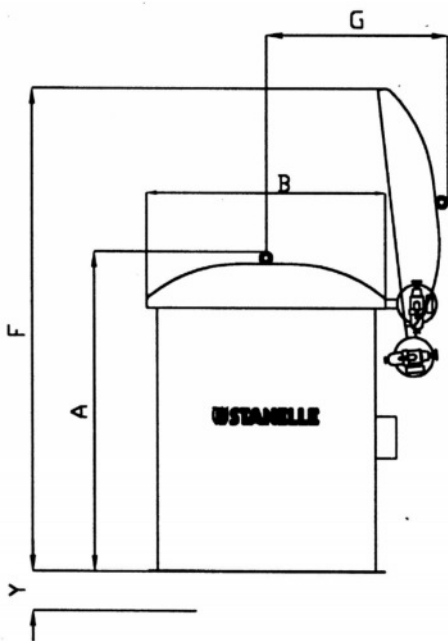

Technical Data Top Filter

Filter area m ²	30	36	42	48
Capacity Nm ³ /h	1500	1800	2100	2400
Maximum temperature	120° C			
Filter cartridges/pc.	6		7	
Filter medium	Polyester			
Solenoid valve/pc.	6		7	
Operating pressure	2,5 bar			
Air connection/mm	ø 13			
Air supply	50 Nltr/min. with a break time of 20 Sec.			
Weight without/with ventilator	345 / 390	345 / 390	345 / 390	370 / 420

Filter cartridge protruding into the silo 200 mm or 400 mm

Technical Data Ventilator

Filter area m ²	30	36	42	48
Ventilator power	1,5 KW	1,5 KW	1,5 KW	2,2 KW
Current consumption approx.	4,48 A / 3,31 A	4,48 A / 3,31 A	4,48 A / 3,31 A	6,2 A / 4,46 A
Motor voltage	230 V / 400 V AC			
Control voltage	230 V / 50 Hz			
Static pressure increase at engine	1800 PA	1800 PA	1800 PA	1860 PA
Volume flow rate max.	3600 m ³	3600 m ³	3600 m ³	4200 m ³

Article Number

Filter area m ²	30	36	42	48
	Article number	Article number	Article number	Article number
without ventilator	722 10 182	722 10 204	722 10 206	722 10 340
with ventilator	722 10 288	722 10 287	722 10 276	722 10 341

Additional sizes and options (e.g. pressure surge protect construction) can be tailored to your special application!

Notice



When placing an order please define the materials which are stored in your silo (e.g. cement, lime etc...)

SEMI-AUTOMATIC TUBE FILTER SYSTEM FOR DRY, POWDERY BULK MATERIALS



**Dedusting filter with
mechanical dedusting**

The filter is used for discontinuous load and convey processes with powdery dry bulk materials.

Areas of application

- Mechanically cleaned tube filter with an out-of-balance shaker.
- Easy maintenance due to 3-door body design and easy to open weather hood.
- Doors with self-closing and adjustable spring lock.
- Equipped with 24 filter tubes made of polyester / polyester needle felt and maintenance friendly clip-in locks including sealing material and fixing screws.

- Steel frame, outside parts are hot-dip galvanised

Details / Explanation

Finish

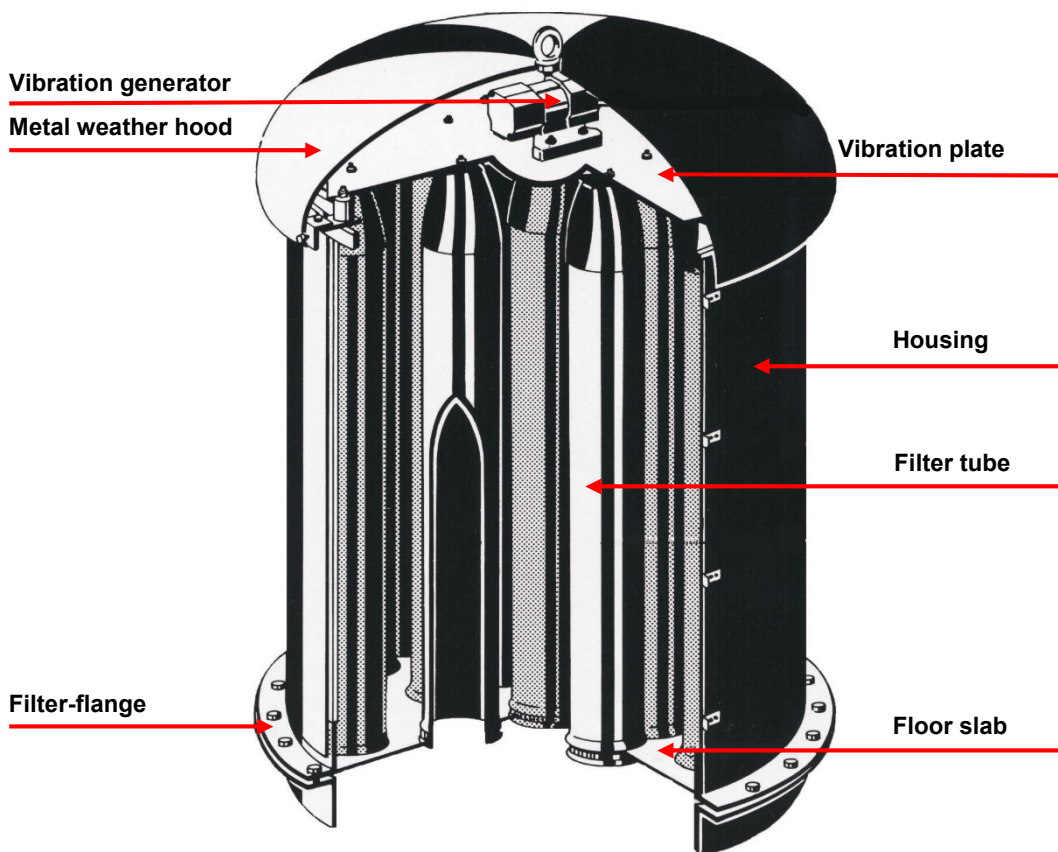

Maintenance friendly design

Without loose or accident-sensitive parts

SCHEME OF STREAMING

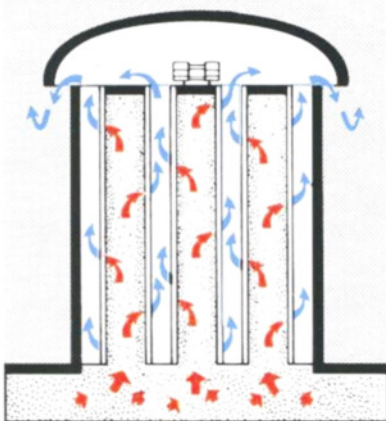

1. Raw gas flows in the filter tubes which are open at the bottom and locked on top. In the process pure gas escapes through the filter cladding and weather hood.

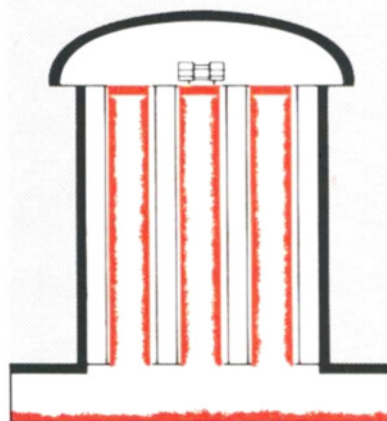

2. After the loading process is finished, the filter tube unit is coated with dust on the inside.

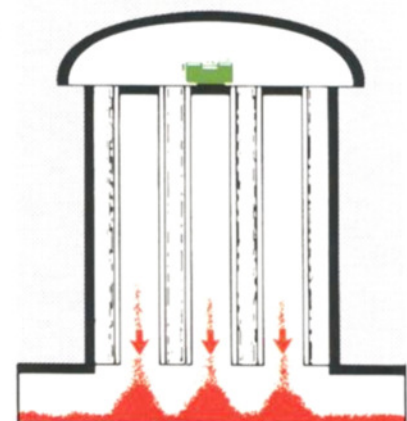

3. Through manual or automatic activation the vibrator starts to oscillate and cleans the tube area. The material flows back into the silo.

Dimensions Stafi

Model	17	20
Outside \varnothing mm	1200	
Inside \varnothing mm	1100	
Hole circle mm	1050	
Number of holes/ \varnothing mm	12 x \varnothing 13	
Height mm	1700	1900
Filter edge \varnothing mm	1100	

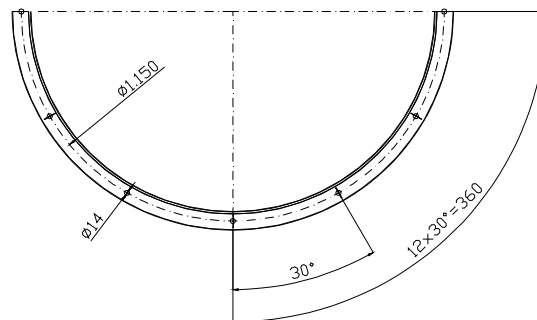
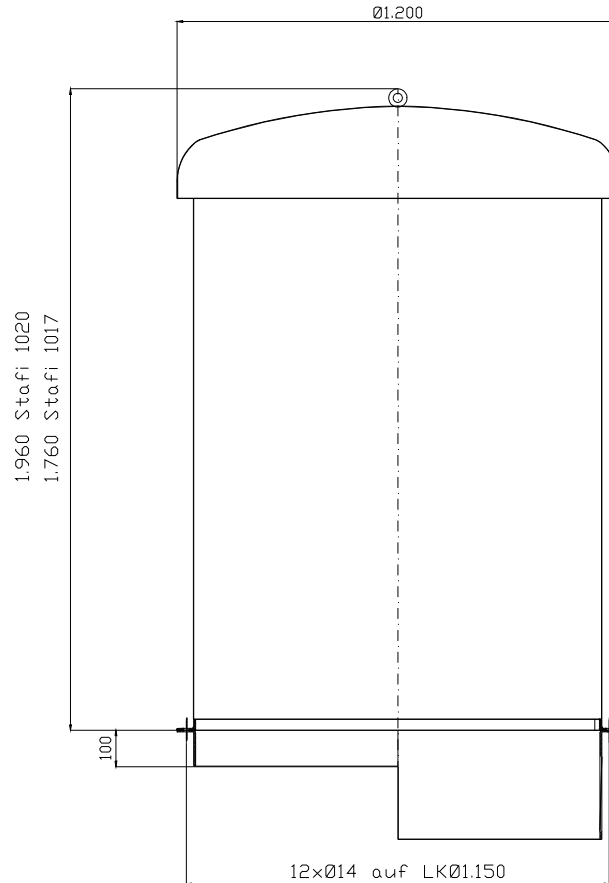

Technical data Stafi

Model	17	20
Capacity Nm ³ /h	800	1000
Maximum temperature	80° C	
Number of filter tubes	24	
Filter medium	Polyester / polyester needle felt	
Weight	146 kg	149 kg
Voltage	400 V / 50 Hz	
Engine Power	0,16 KW	

Article Number

Model	17	20
	Article number	Article number
Design in steel	721 10 196	721 10 198
Design in stainless steel	721 10 092	721 10 094
Antistatic filter tubes + stainless steel bottom plate (1.4301)	721 10 200	721 10 201

Extra Charges For

Transport Design	Article number
Filter is designed for lying transportation, with boosted filter frame, 3-door body (without easy to open weather hood). Rubber collar to cover the air outlet between weather hood and filter body (avoids the entrance of splash and rain water).	721 10 182

Filter top frame with exhaust air socket	Article number
Filter frame in reinforced design with 3 doors. Filter attachment with exhaust air socket DN 200 (Jacob flange) as well as with sealed weather hood (height increases for about 300 mm).	721 10 116

Bottom plate made of stainless steel (1.4301)	Article number
For Stafi in steel design	721 10 065

Additional sizes and options can be tailored to your special application!

When placing an order please define the materials which are stored in your silo (e.g. cement, lime etc...)

Notice!



Fully automatic filter control	Article number
<p>For fully automatic activation of filter dedusting before and after filling the silo. By actuating a lockable clamp (padlock) a rugged mechanical limit switch is activated. As a result coupling and uncoupling of the loading tube activates the dedusting process through a timer.</p> <p>Timer in plastic housing (IP 54) for installation on the silo or switching box of the overfill protection.</p> <p>Voltage 230/400 V / 50 Hz.</p>	<p>881 10 003</p>



Semi-automatic filter control	Article number
<p>For semi-automatic activation of the filter dedusting by manual activation (pushbutton), consisting of:</p> <p>Pushbutton and timer in the plastic housing (IP 54) for installation on the silo or switching box of the overfill protection.</p> <p>Voltage 230/400 V / 50 Hz.</p>	<p>881 10 025</p>









Equipment / Spare parts

Filter type	Article number	
Filter hose 1014 Polyester, Clipin Set 24 pieces	721 10 133	
Filter hose 1014 Needle felt, Clipin Set 24 pieces	721 10 130	
Filter hose 1014 Needle felt, Clipin Set 24 pieces ATEX	721 10 131	
Filter hose 1017 Polyester, Clipin Set 24 pieces	721 10 138	
Filter hose 1017 Needle felt, Clipin Set 24 pieces	721 10 135	
Filter hose 1017 Needle felt, Clipin Set 24 pieces ATEX	721 10 136	
Filter hose 1020 Polyester, Clipin Set 24 pieces	721 10 143	
Filter hose 1020 Needle felt, Clipin Set 24 pieces	721 10 140	
Filter hose 1017 Needle felt, Clipin Set 24 pieces ATEX	721 10 141	
Tension lock with safety device	721 10 107	
Counter hook for tension lock	721 10 117	

Installed centred on silo roof, nominal diameter 1100 mm, height 100 mm	721 10 006 Made of steel plate, primed	
	721 10 063 Made of stainless steel	
Installed decentred on the silo roof (e.g. separating plate silo) nominal diameter 1100 mm, height 200 mm.	721 10 005 Made of steel plate, primed	
	721 10 064 Made of stainless steel	
Metal weather hood	721 10 110	
Locking screw	721 10 074	
Vibration generator 400 V / AC	882 10 001	
Vibration generator, ATEX , II 2 G/D 	882 10 013	
Vibration plate	721 10 048	
Rubber-bonded metal	721 10 043	
Housing, 3 parts Door for STAFI 1014	721 10 072	
Housing, 3 parts Door for STAFI 1017	721 10 071	
Housing, 3 parts Door for STAFI 1020	721 10 111-01	
Floor slab	721 10 029	

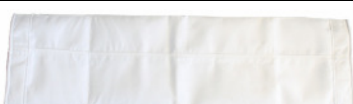
Putty cord	721 10 183	
Gas pressure spring	721 10 073	

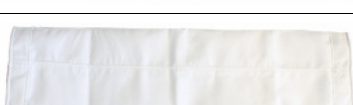
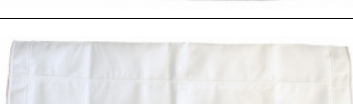
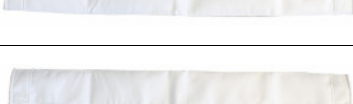
Equipment / Spare parts old version Stafi

Filter type	Article number	
Tubular tape for old version Stafi 1010 Needle felt, Clipin Set 24 pieces	721 10 124	
Tubular tape for old version Stafi 1010 polyester, Clipin Set 24 pieces	721 10 127	
Tubular tape for old version Stafi 1014 Needle felt, Clipin Set 24 pieces	721 10 129	
Tubular tape for old version Stafi 1014 polyester, Clipin Set 24 pieces	721 10 132	
Tubular tape for old version Stafi 1017 Needle felt, Clipin Set 24 pieces	721 10 134	
Tubular tape for old version Stafi 1017 polyester, Clipin Set 24 pieces	721 10 137	
Tubular tape for old version Stafi 1020 Needle felt, Clipin Set 24 pieces	721 10 139	
Tubular tape for old version Stafi 1020 polyester, Clipin Set 24 pieces	721 10 142	
Tubular tape D 160 for Stafi old version	721 10 019	

**FOR SMOOTH DEDUSTING OF MIXING PROCESSES AND
CONVENIENT DUST RECYCLING**



**Filter materials with
extra long durability**

**Made possible
through outstanding
construction design**

**Easy integration into
existing systems**

Areas of application

The MIXFI is a mixing filter used for direct dedusting of mixed charges.

Details / Explanation

- Smooth dust recycling of filter dusts to the mixer
 - Direct installation on top of an exhaust air chute or
 - Dust collection box design with aspiration port on the side through which the mixing filter can be installed directly next to the mixer and dedust it through a flexible tube
 - Special dedusting system with vacuum flaps respectively leak air at the mixer cleanout
 - Clocked relay for cleaning the filter cartridges (optional)
-
- Rust removal: SA 2,5
 - Primer: 2K; 40µm
 - Top coat: 2K; RAL 9006; 40µm

Finish

Dimensions Mixfi

Model	10	15	18	21
a / a+	600 / 480	800 / 490	800 / 460	800 / 990
b / b+	1390 / 50	1390 / 90	1590 / 85	1790 / 165
c / c+	300 / 205	400 / 145	400 / 115	400 / 240
d	660	860	860	860
e	330	460	460	460
f	105	166	166	166
g	750	950	950	950
h	3 x 100	2 x 215	2 x 215	2 x 215
Ø l	295	295	295	295
m	250	400	400	400

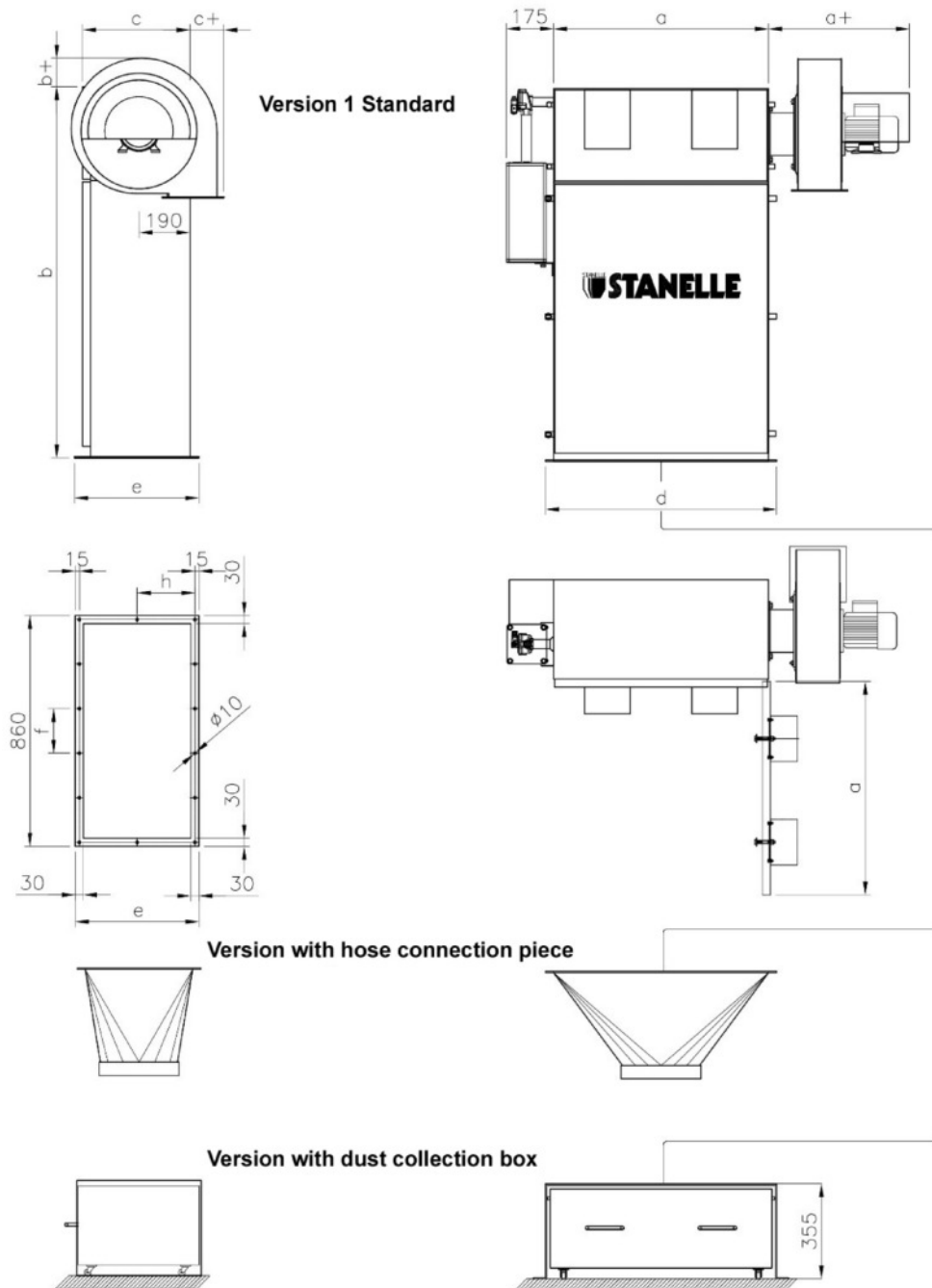

Technical data Mixfi

Model	10	15	18	21
Mixer size to	1.125 ltr.	2.500 ltr.	4.500 ltr	6000 ltr
Capacity/ Nm ³ / h	500	750	900	1050
Maximum temperature	120° C			
Filter cartridges / pcs.	3			
Filter medium	polyester			
Solenoid valve / pcs.	1			
Operating Pressure	4 bar			
Air connection / mm	ø 12			
Actuation air	105 Nltr/ min. with a break time of 20 sec.			
Weight kg	80	110	120	140
Fan power kW	0,37	0,75	1,1	1,5
Fan voltage	230 / 400 V			

Article number

Model	10	15	18	21
Article number	722 10 266	722 10 269	722 10 272	722 10 301

Additional price for

Dust collection box for model	10	15	18	21
Article number	722 10 105	722 10 104	722 10 104	722 10 104

Fan and solenoid valve voltage are variable and also available in Ex-version!

Notice



Further sizes and applications (e.g. pressure shock resistant design) according to your requirements, possible on request!

Notice



Please indicate the media to be mixed when placing the order. E.g. cement, lime, etc.

Accessories for Mixfi

Dedusting control for top hat rail installation	Article number
For dedusting of the mixing filter during the mixer cleanout. Control board for on site installation into the control box. Blow time set up, break time adjustable via potentiometer (2 - 15 s). Voltage 230 V AC	881 10 062
Alternative: Mounted to the plastic box on the filter and completely wired. Control process see above. Voltage 230 V AC	881 10 063



Additional accessories for Mixfi

Adapterflange: To flange on the mixing filter. Hose connection specification S235JR, Rust removal SA 1. Primer and top coat RAL 9006	Mixfi 10	Mixfi 15 / 18		Mixfi 21
	Ø 300	Ø 300	Ø 500	Ø 500
Article number	722 10 012	722 10 082	722 10 139	722 10 139



Spiral tube: For connecting the mixer air vent with the adapter flange of the mixing filter. To exhaust air/dust mixture from the mixer. Each running meter	Mixfi 10	Mixfi 15 / 18		Mixfi 21
	Ø 300	Ø 300	Ø 500	Ø 500
Article number	722 10 080	722 10 080	722 10 074	722 10 074



Special tube clamp: for spiral tube	Ø 300	Ø 500
Article number	722 10 103	722 10 075

Equipment / Spare parts

	Article number	
Quick-release flap for Mixfi 10 / GCM2510	722 10 369	
Quick-release flap for Mixfi 15 / GCM2810	722 10 375	
Quick-release flap for Mixfi 18 / GCH3540	722 10 374	

Equipment / Spare parts

Model	10	15	18	21	
	Article number				
Filter cartridge SLP Standard	722 10 172	722 10 001	722 10 158	722 10 171	
Filter cartridge SLP antistatic ATEX 	722 10 088	722 10 087	722 10 057	722 10 135	
Filter cartridge SLP up to 150°C	722 10 325	722 10 218	722 10 183	On request	
Valve cover set without coil for ATEX / 881 10 210 	881 10 268				
Valve cover set 24V/DC, consisting of valve cover and electric coil	881 10 245				
Valve cover set 230 V/AC, consisting of valve cover and electric coil	881 10 247				
Diaphragm for quick relief valve	881 10 246				
Solenoid valve, 24V/DC	881 10 245-01				
Solenoid valve, 230V/AC	881 10 247-01				
Valve covers	881 10 253				

Valve connector type BI, cable 2m	881 10 401	
Filter regulator G 1/2"	874 10 001	
Solenoid valve complete 24V/AC / 24V/DC Old filter design (until 2013)	On request	

Fan and solenoid valve coils -voltage are variable and also available in Ex-version!

Notice



Further sizes and applications according to your requirements, possible on request!

When placing the order, please indicate the media to be promoted. E.g. cement, lime, etc.

FOR EFFICIENT JET-LOADER DEDUSTING WHEN LOADING SILO VEHICLES AND CONTAINERS.



Loading filter is available in explosion proof design

The loading filter type BELFI is used for direct dedusting and dust recirculation when loading silo vehicles and containers with a jet loader.
Other applications, such as belt transfer point dedusting, elevator dedusting.

Areas of application

- Efficient loader dedusting
 - Compact design
 - Easy access for convenient cleaning and maintenance
 - Filter dusts are returned to the bulk material - no hazardous waste is produced
 - Optional vacuum flap / optional tuned filter controller
-
- Rust removal: SA 2,5
 - Primer: 2K; 40µm
 - Top coat: 2K; RAL 9006; 40µm

Details / Explanation

Finish

Dimensions Belfi

Model	10	15	18	21
Jet loader Loading capacity m ³ /h	100	150		180
Fan suction capacity Nm ³ /h	600	900	1300	2000
a	600	800		
b	1440	1640	1840	1840 + 200
c / c+	300 / 150	400 / 148	400 / 126	400 / 126
d	660	860		
e	330	460		
f	6 x 105	5 x 166		
h	3 x 100	2 x 215		
i	50	20	12	12
k	520	525	520	520

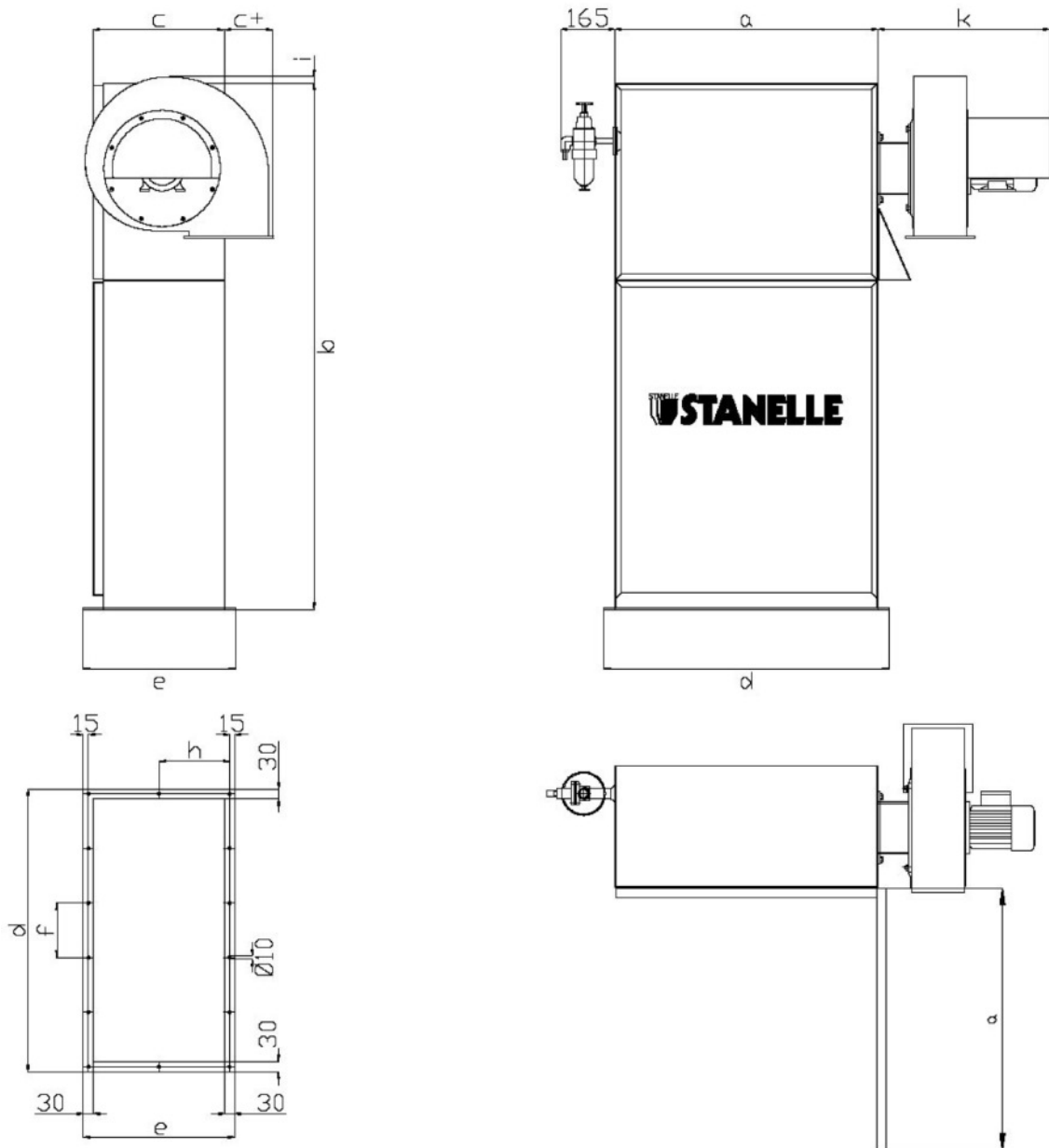





Technical data Belfi

Model	10	15	18	21
Capacity Nm ³ /h	500	750	900	1050
Maximum temperature	120° C			
Filter cartridges / pcs.	3			
Filter medium	polyester			
Solenoid valves / pcs.	3			
Operating pressure	2,5 bar			
Air connection, mm	ø 12			
Actuation air	75 Nltr/min. with a break time of 20 sec.			
Weight, kg	85	120	135	155





Article number



Model	10	15	18	21
Article number	722 10 338	722 10 251	722 10 261	722 10 336

Clock control for Belfi

	Article number	
Control unit FST 3-4 Supply voltage 230V/AC Standard	881 10 206	
Control unit FST 3-4 Supply voltage 24V/DC Standard	881 10 240	
Filter control FST 3-4 Supply voltage 24V ATEX Zone 22 	881 10 265	

Equipment / Spare parts

Model	10	15	18	21	
Article number					
Filter cartridge SLP standard	722 010 172	722 10 001	722 10 158	722 10 171	
Filter cartridge SLP antistatic ATEX 	722 10 088	722 10 087	722 10 057	722 10 135	
Filter cartridge SLP by 150°C	722 10 325	722 10 218	722 10 183	On request	
Valve cover set without coil ATEX / 881 10 210 	881 10 268				
Valve cover set 24V/DC, consisting of diaphragm, electric coil	881 10 245				
Valve cover set 230 V/AC, consisting of diaphragm, electric coil	881 10 247				
Diaphragm for quick relief valve	881 10 246				
Magnetic valve, 24V/DC	881 10 245-01				
Magnetic valve, 230V/AC	881 10 247-01				
Valve cover	881 10 253				

Valve connector Typ BI, cables 2m	881 10 401	
Filter regulator G 1/2"	874 10 001	
Magnetic valve complete, 24V/AC / 24V/DC old filter version (up to year of construction. 2013)	on request	
Transition piece 90° S235JR from loader to filter Belfi 10	754 10 001	
Transition piece 60° S235JR from loader to filter Belfi 10	754 10 002	
Transition piece 90° S235JR from loader to Filter Belfi 15/18/21	754 10 003	
Transition piece 60° S235JR from loader to Filter Belfi 10 with internal cleaning	754 10 002-01	
Transition piece 60° S235JR from loader to Filter Belfi 15/18/21 with internal cleaning / pneumatic	754 10 004-01	

**For the corresponding BELFI filter sizes, different
VA stainless steel versions available.**

Notice



**Fan and solenoid valve coils voltage are variable and also available in Ex-
version!**

**Further sizes and applications according to your requirements, possible
on request!**

**When placing an order, please indicate the media to be pumped. e.g.
cement, lime, etc.**

FOR ECONOMICAL DEDUSTING OF LOADERS, BUNKERS AND CONVEYOR BELTS



**Ulufi also available in
explosion proof design**

Picture: Ulufi 10 in antistatic design

The ULUFI is an electrically controlled fully automatic filter with side-folding clean gas housing, which serves for direct dedusting and dust recirculation when loading silo vehicles and containers with a jet loader and - due to its extremely compact design and performance - for conveyor belt dedusting.

Areas of Application

- Economical dedusting of loaders, conveyor belts and bunkers
- Compact design
- Large door openings for easy cleaning and maintenance
- Variable designs
- Filter dusts are returned to the bulk material - no hazardous waste is produced
- High degree of separation (residual dust content < 5 mg/m³)
- Including control (optionally time (standard) or differential pressure controlled)

- Rust removal: SA 2,5
Primer: 2K; 40µm
Top coat: 2K; RAL 9006; 40µm

Details / Explanation

Finish

Dimensions Ulufi (mm)

Model	Ulufi 10	Ulufi 15	Ulufi 18	Ulufi 26	Ulufi 38	Ulufi 54
a	400	540	540	750	1330	1700
b	1620	1620	1800	1920	1770	2000
c	800	800	1000	1000	1000	1000
e	1000	1120	1120	1300	1470 *	1850 *
f	1220	1320	1380	1580	1440 *	1640 *
g	460	600	600	810	1390	810
h	860	860	1060	1060	1060	1060
i x j	2 x 215	2 x 285	2 x 285	2 x 260	5 x 272	2 x 260
k x l	5 x 166	4 x 207,5	5 x 206	5 x 206	5 x 206	5 x 206

(*) Filter unit with 2 doors

Dimension drawing: Pressure vessel bottom (alternatively top) / door hinge left (alternatively right)

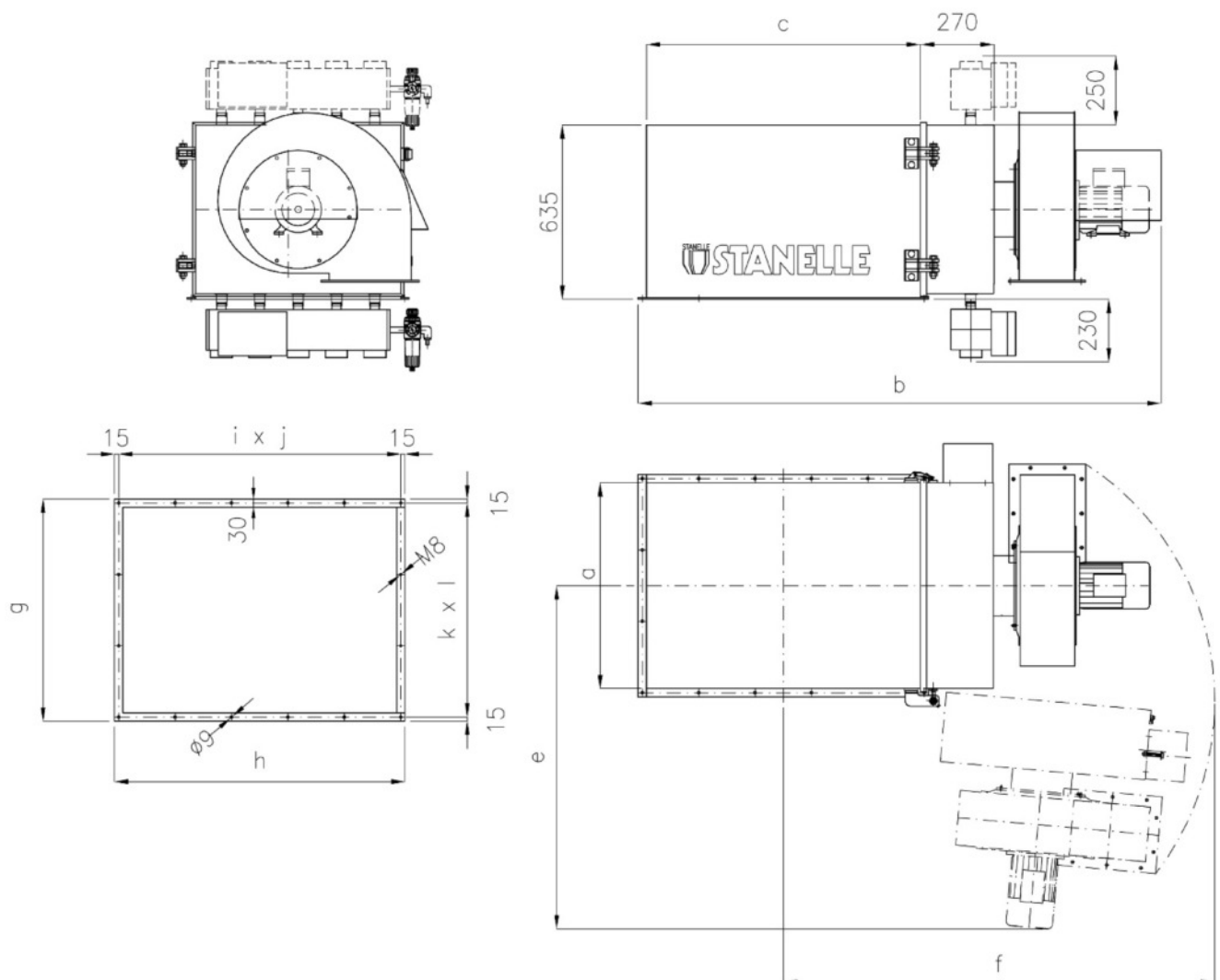



Picture: Ulufi 38 with aspiration shoe for conveyor belt 800mm after steel roller, as well as silencer

Technical Data Ulufi with fan

Model	Ulufi 10	Ulufi 15	Ulufi 18	Ulufi 26	Ulufi 38	Ulufi 54
Capacity/ Nm ³ / h	500	750	900	1300	1900	2700
Maximum temperature	80° C bzw. on request with special filter media					
Filter cartridges / pcs.	5	7	7	10	2 x 8	2 x 11
Size Filter plates / mm	494 x 800	494 x 800	494 x 1000	494 x 1000	494 x 1000	494 x 1000
Filter medium	polyester					
Solenoid valve / pcs.	3	4	4	5	2 x 4	2 x 6
Operating Pressure	4 bar					
Air connection	hose nozzle 12 mm					
Actuation air	105 Nltr/min with a break time of 20 sec.					
Fan voltage	230 / 400 V					
Fan power, kW	0,37	0,75	1,1	1,5	2 x 1,1	2 x 1,5
Weight / kg (ca.)	130	175	240	300	391	620

The model number corresponds approximately to the filter area in m². The exact filter area depends on the filter media selected for the application.

Article number

Model	Ulufi 10	Ulufi 15	Ulufi 18	Ulufi 26	Ulufi 38	Ulufi 54
	Article number					
Standard with fan	722 10 302	722 10 062	722 10 379	722 10 216	722 10 328	722 10 308
execution ATEX 20/22 with fan	722 10 401	722 10 402	722 10 403	722 10 299	722 10 406	722 10 408
Execution as Silo bunker filter without fan	722 10 302-60	722 10 062-60	722 10 379-60	722 10 216-60	722 10 328-60	722 10 308-60

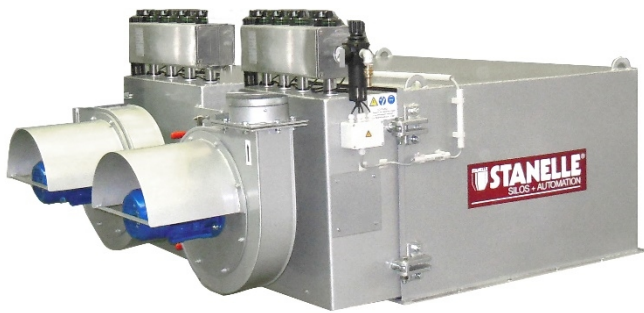

Picture: Ulufi 38 with fan



Picture: Ulufi 54 Silo-Bunker Top filter (exhaust air nozzle) without fan, DP control Differential pressure

Filterelemente

Model	Ulufi 10	Ulufi 15	Ulufi 18	Ulufi 26	Ulufi 38	Ulufi 54
	Article number					
Standard	722 10 201	722 10 201	722 10 151	722 10 151	722 10 151	722 10 151
Execution ATEX 20/22	722 10 450	722 10 450	722 10 309	722 10 309	722 10 309	722 10 309

Other sizes and applications according to your requirements are available on request!



Please indicate the characteristics of the media to be pumped when making an enquiry: e.g. cement, lime, animal feed, salt, sugar, etc.







Picture: Ulufi 10 with aspiration shoe for conveyor belt 650mm









Picture: Belt and loader dedusting system

Clock control for Ulufi

	Article number	
Control unit FST 3-4 Supply voltage 230V/AC Standard	881 10 206	
Control unit FST 3-4 Supply voltage 24V/DC Standard	881 10 240	
Control unit FST 3-4 Supply voltage 24V ATEX Zone 22 	881 10 265	
Control unit FST 3-8 Supply voltage 24V/DC Standard	881 10 207	

Differential pressure control for Ulufi







	Article number	
Control DP4 for pneumatic filters, connection voltage 230 V/AC for 4 solenoid valves 24V/DC for silo application	881 10 209	
Control DP4 for pneumatic filters, supply voltage 24 V/DC for 4 solenoid valves 24V/DC for silo application	881 10 209-24V	
Control DP4 for pneumatic filters, connection voltage 230 V/AC ATEX Zone 22 for 4 pneumatic valves for silo application 	881 10 210	
Control DP4 for pneumatic filters, supply voltage 24 V/DC ATEX Zone 22 for 4 pneumatic valves 	881 10 210-24V	
Control DP8 for pneumatic filters, Ulufi 26 - 54, Supply voltage 230 V/AC ATEX Zone 22 for 7 pneumatic valves	881 10 267	

Equipment / Spare parts

	Article number	
Weld-in frame Ulufi 10	722 10 398	
Weld-in frame Ulufi 15	722 10 386	
Weld-in frame Ulufi 18	722 10 188	
Weld-in frame Ulufi 26	722 10 371	
Weld-in frame Ulufi 38	722 10 384	
Weld-in frame Ulufi 54	722 10 385	

Equipment / Spare parts

	Article number	
Compact filter element suitable for Ulufi 10 / 15	722 10 201	
Compact filter element suitable for Ulufi 18 / 26 / 38	722 10 151	
Compact filter element suitable for Ulufi 10 / 15 ATEX	722 10 450	
Compact filter element suitable for Ulufi 18 / 26 / 38 ATEX	722 10 309	
Mounting rail with Venturi nozzle	722 10 417	
Valve cover set without coil for ATEX / 881 10 210	881 10 268	
Valve cover set 24V/DC, consisting of valve cover and electric coil	881 10 245	
Valve cover set 230 V/AC, consisting of valve cover and electric coil	881 10 247	
Diaphragm for quick relief valve	881 10 246	

Solenoid valve, 24V/DC	881 10 245-01	
Solenoid valve, 230V/AC	881 10 247-01	
Valve covers	881 10 253	
Valve connector type BI, cable 2m	881 10 401	
Filter regulator G 1/2"	874 10 001	
Solenoid valve complete 24V/AC / 24V/DC Old filter design (until 2013)	auf Anfrage	

**CARTRIDGE FILTER
MECHANICAL CLEANING**

WITH BLOWER OR ASPIRATION SPOUT



The Filter Stafi R will be used for a dis-continuous filling / conveying process with powder and dry bulk products.

**Areas of
Application**

- Dedusting of container with mechanical infeed
- Dedusting of discontinuous operated conveying systems like screw conv., chain conv. bucket elevator etc.

- Easy assembly
- Cartridge filter with vibrator
- High quality cartridge filter
- Low dust emission
- Easy and toolless maintenance
- Filter housing made of constructional steel S235JR, lackiert or stainless steel
- Design according to European ATEX directive suitable for use in Zone 20/22

Details / Design

- Rust removal: SA 2,5
- Primer: 2K; 40µm
- Top coat: 2K; RAL 9006; 40µm

Finish

The numbers of switch ON/Off / minute depends on dust quantity and product.

Notice

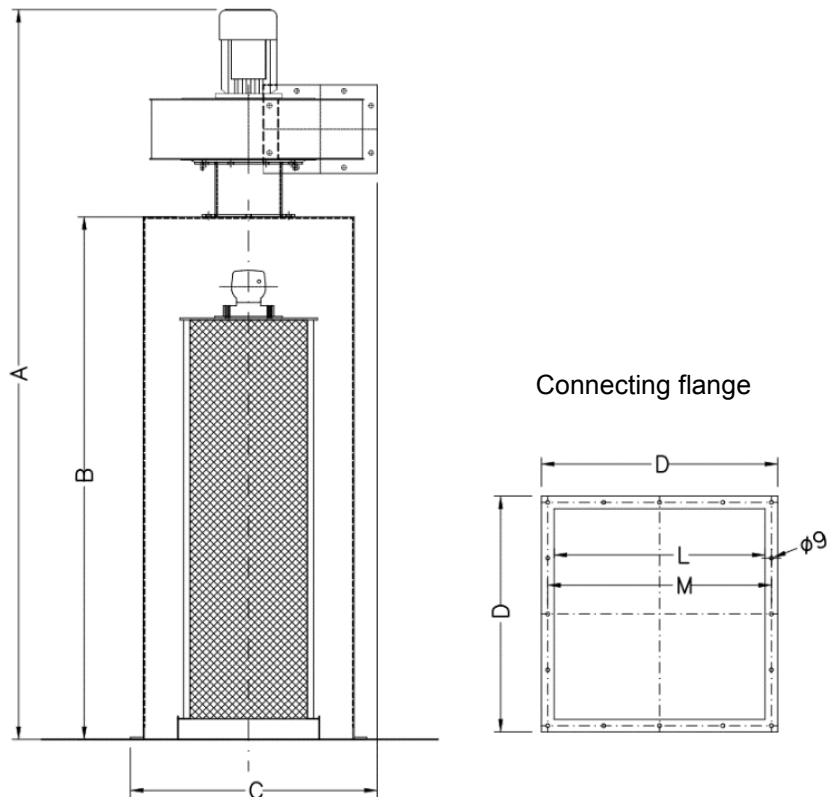

Dimensions

Model	4	6	8	10
A With blower mm	1260	1260	1735	1735
B Without blower mm	740	740	1240	1240
C mm	585	700	585	700

Dimension table connecting flange

Model	4	6	8	10
D Outside mm	560 x 560	700 x 700	560 x 560	700 x 700
L Inside ϕ mm	500 x 500	600 x 600	500 x 500	600 x 600
M mm	530	650	530	650
Numbers of holes / $\phi 9$ mm	16	16	16	16

Technical Data Top Filter

Model	4	6	8	10
Capacity (Nm ³ /h)	200	300	400	500
Max. temperature	120° C			
Filter cartridges / pcs.	1			
Filter medium	polyester			
Weight with aspiration spout kg	80	95	115	135
Weight with blower	95	110	130	150

Article number

Model	4	6	8	10
	Article number	Article number	Article number	Article number
With blower	721 10 275	721 10 283	721 10 268	721 10 272
With aspiration spout	721 10 275-01	721 1 0283-01	721 10 270-02	721 10 271-02
With aspiration spout VA	721 10 275-02	721 10 283-02	721 10 270	721 10 271
With aspiration spout ATEX VA20/22	721 10 275-03	721 10 283-03	721 10 270-03	721 10 271-03
With blower ATEX	721 10 275-04	721 10 283-04	721 10 270-04	721 10 271-04

Accessories / Spare parts

Model	4	6	8	10
	Article number	Article number	Article number	Article number
Welded frame S235	721 10 281-01	721 10 282-01	721 10 281-01	721 10 282-01
Filter cartridge Standard	722 10 419	722 10 560	722 10 409	722 10 016
Filter cartridge ATEX	722 10 418	722 10 560-01	722 10 412	722 10 019
Vibrator 400V / 50 Hz	882 10 012			
Vibrator 230V / 50 Hz ATEX	882 10 019			

Other sizes and applications according to your requirements, possible on request!
When placing the order, please indicate the media in the silo
(e.g. cement, lime, sand, sugar, etc.).

Hinweis



FOR EFFEKTIVE DEDUSTING OF SCALES



**Zewafi available on
request in Ex-protected
version**

picture: Zewafi 3 in ATEX Zone 20/22 Design

The Stanelle filter type ZEWAFI is an electrically controlled fully automatic filter with external pressure vessel and will be used for dedusting scales.

The ZEWAFI includes a pressure reducing valve and is ready for operation after connection to the on-site supply of dry, technically clean compressed air at an operating pressure of 3 - 4 bar and integration into the higher-level control system. It can be used for a operation temperature area up to 130 °C. In combination with the Stanelle Mixfi mixer filters, the Zewafi is a universal solution for mixing plants with aggregate scales.

**Areas of
application**

The filter cartridges, which can be supplied in different qualities, can be replaced without the use of tools. The filter door can be removed after a lock has been released so that the cartridge can be accessed immediately. The cartridge is cleaned pneumatically by a quick release valve. The high-quality, star-folded fleece fabric (PTFE-coated polyester as standard) ensures a low residual dust content of the filtered air.

Details / Explanation

- Economical dedusting of scales, especially cement scales.
- Extremely compact design
- Large door openings for easy cleaning and maintenance. Variable Bauformen.
- Filter dust is returned to the bulk material - there is no hazardous waste.
- High degree of separation (residual dust content < 5 mg/m³).
- The control system must be provided by the customer or integrated into the mixer/scale control system. - Optionally a Stanelle clock control is also possible.

- Filter housing made of sheet metal, painted in RAL 9006.
- **Other materials, e.g. stainless steel on request**

Finish

Dimensions Zewafi (mm)

Model	Zewafi 3	Zewafi 4	Zewafi 5	Zewafi 6
a	1020	850	1420	1250
b	400	548	400	548
c	400	250	400	250
d	454	580	454	580
e	454	310	454	310

Dimensioned drawing Zewafi 4 / 6

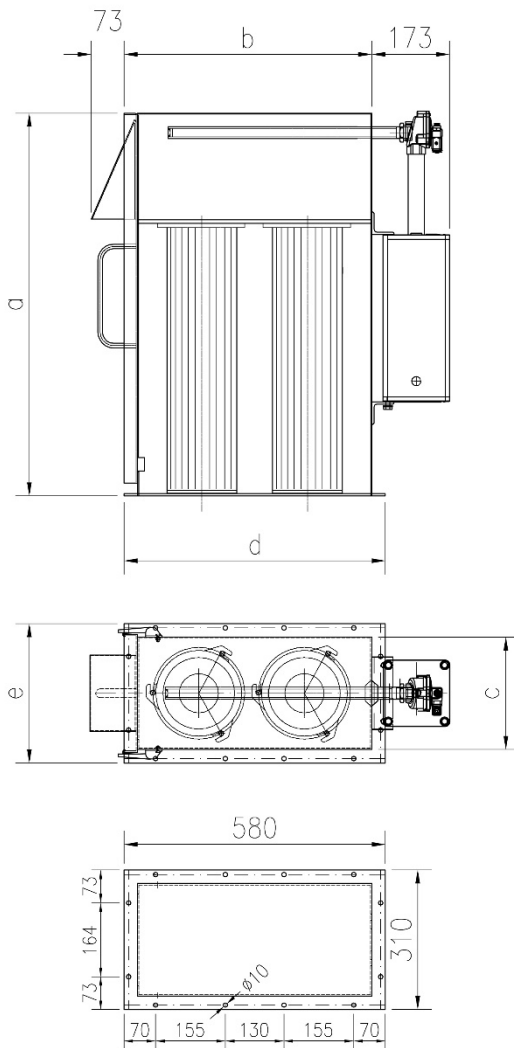

Dimensioned drawing Zewafi 3 / 5

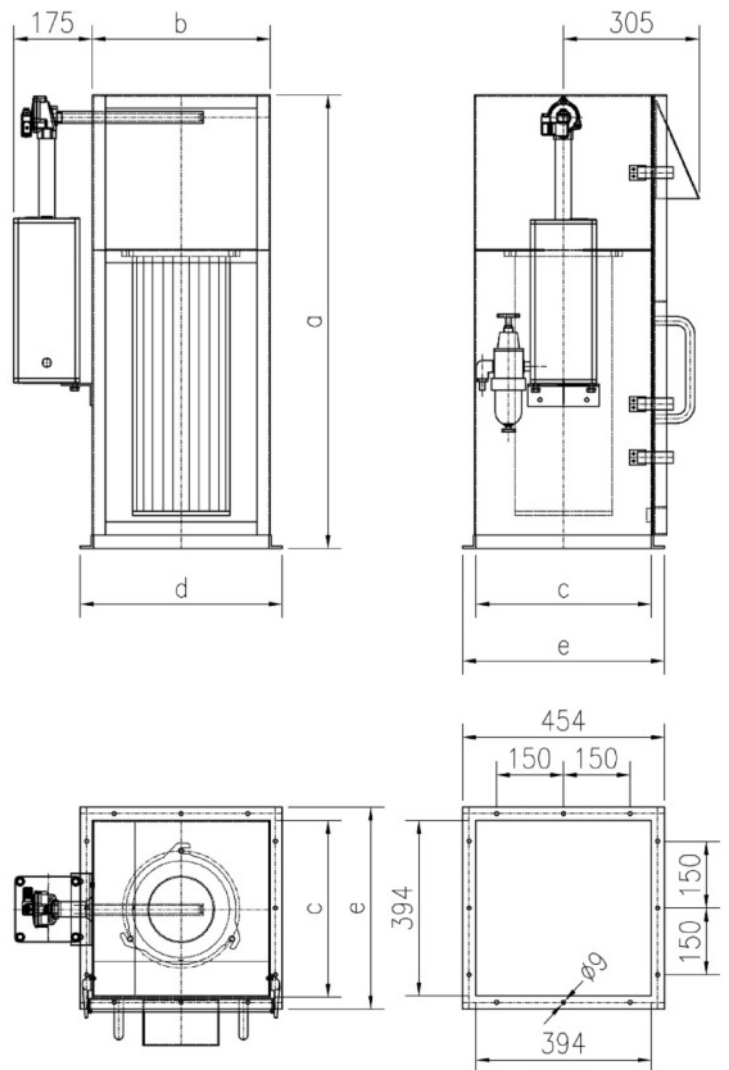

Tecnical data Zewafi

Model	Zewafi 3	Zewafi 4	Zewafi 5	Zewafi 6
Capacity Nm ³ /h	150	250	250	300
Maximum temperature	100°C or according to requirements with special filter media			
Filter cartridges / pcs.	1	2	1	2
Size / mm	225 x 600	150 x 600	225 x 1000	150 x 1000
Filter medium	polyester			
Solenoid valves / pcs.	1	1	1	1
Operating pressure	2,5 bar			
Air connection	hose nozzle 12 mm			
Actuation air	75 Nltr/min with a break time of 20 sec.			
Weight / kg (ca.)	60	65	70	80

The model number corresponds approximately to the filter area in m². The exact filter area depends on the filter media selected for the application.

Article number

Model	Zewafi 3	Zewafi 4	Zewafi 5	Zewafi 6
Standard	722 10 293	722 10 354	722 10 501	722 10 502
ATEX 20/22	722 10 509	722 10 510	722 10 511	722 10 512

Filter elements

Model	Zewafi 3	Zewafi 4	Zewafi 5	Zewafi 6
Standard	722 10 550	722 10 006	722 10 001	722 10 173
ATEX 20/22	722 10 551	722 10 018	722 10 087	722 10 088

Other sizes and applications according to your requirements are available on request!

Please indicate the characteristics of the media to be pumped when making an enquiry: e.g. cement, lime, animal feed, salt, sugar, etc.

Notice



OVER PRESSURE / VACUUM FLAPS

SDAK 150



SDAK 300



SDAK 400

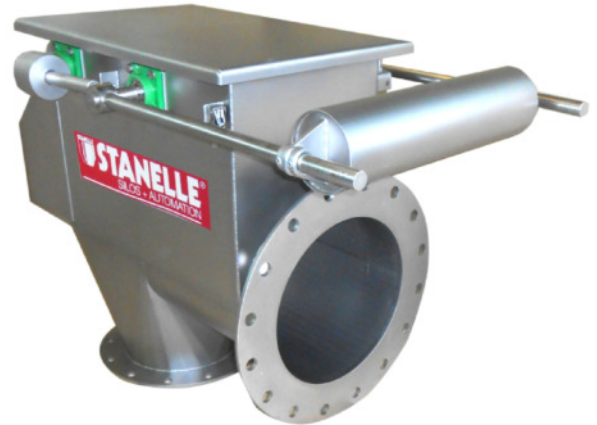

The over pressure / vacuum flaps model SDAK are important safety flaps for silos which are filled pneumatically. Once installed, the flaps balance over pressure as well as vacuum caused by exhaust ventilators or cornice collapse. Due to the maintenance free construction of the SDAK, guarantees an optimal protection. The SDAK is also suitable for protecting ventilation systems/pipes and the folding beams of our loaders.

Areas of Application

- All bearings are lubricated for life
- Exactly routed flow of exhaust air
- Over pressure level stepless adjustable
- Overpressure range / vacuum range continuously adjustable depending on the version
- Overpressure up to 250mbar / Vacuum down relative to 200 mbar as possible options / special design
- As an additional option the flap can be equipped with non-contacting limit switches. When used with silos and containers inside, the flap can be delivered with an exhaust air socket to ensure a smooth diversion of air through pipelines or hoses.

Details / Explanation

- Material:
Steel S235
Rust removal: SA 2,5
Primer: 2K; 40µm
Top coat: 2K; RAL 9006; 40µm

Finish

- Material:
Stainless steel 1.4301
Beads blasted

- Material:
Stainless steel 1.4571
Beads blasted

Dimensions Over Pressure / Vacuum Flaps

	A	B	C	D	E	H	J	K	L
SDAK 150 Standard	265	355	154	154	240	706	240	540	415
SDAK 150 Twin lever	265	355	154	154	240	706	240	590	528
SDAK 300	427	617	260	260	315	902	420	810	750
SDAK 400	527	763	309	309	450	1133	508	992	998

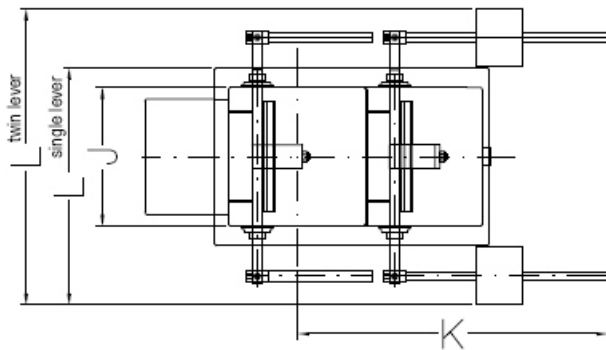
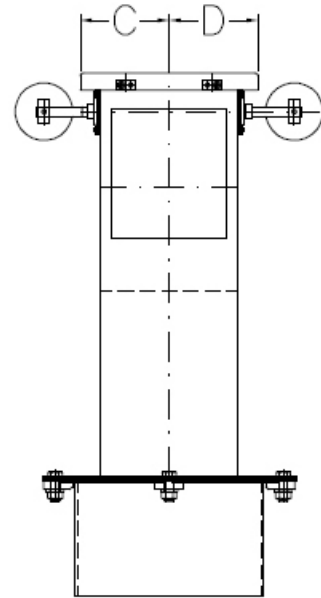
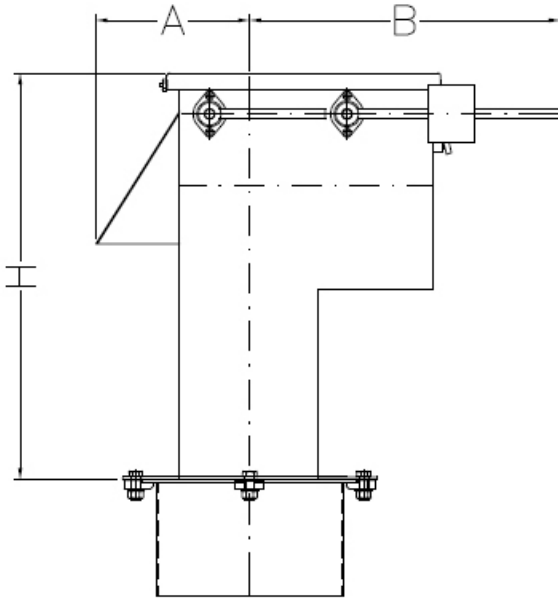

connection flange SDAK 150

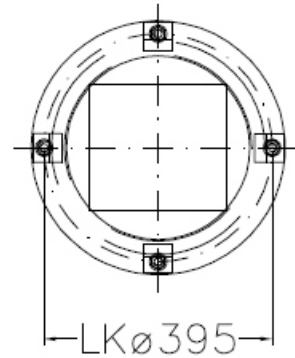

connection flange SDAK 400

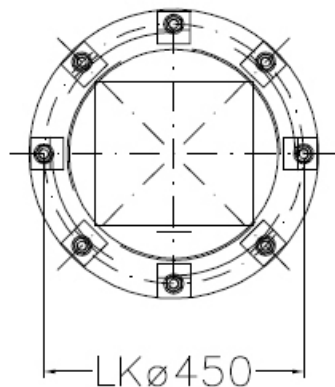

connection flange SDAK 300

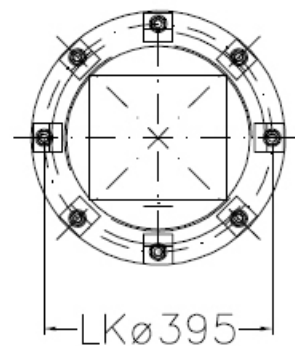

	SDAK 150 Standard	SDAK 150 Twin lever	SDAK 300	SDAK 400
Over pressure	60 mbar Version: 20 mbar – 70 mbar	60 mbar Version: 20 mbar – 70 mbar	60 mbar Version: 20 mbar – 70 mbar	20 mbar Version: 10 mbar – 70 mbar
Vacuum	-5 mbar	-5 mbar Version: -5 mbar bis -25 mbar	-5 mbar Version: -5 mbar bis -25 mbar	-5 mbar Version: -5 mbar bis -25 mbar
Temperature	80°C	80°C	80°C	80°C
Max. air capacity	2200 m³/	2200 m³/	8500 m³/h	15000 m³/h
Weight	45 kg	51 kg	235 kg	500 kg

Additional pressures (e.g. + 200mbar), temperature range (e.g. + 250°C) or other versions on request!

Article number





	SDAK 150 Standard	SDAK 150 Twin lever
	Article number	Article number
Version: Standard steel S235JR	762 10 003	762 10 037
Version: Stainless steel 1.4301 (1.4571 on request)	762 10 010	762 10 075
Version: Standard steel S 235JR with exhaust air pipe	762 10 014	762 10 076
Version: Stainless steel 1.4301 (1.4571 on request) with exhaust air pipe	762 10 015	762 10 075
Version: Standard steel S235JR ATEX 20/22	762 10 056	762 10 068
Version: Stainless steel 1.4301 (1.4571 on request) ATEX 20/22	762 10 083	762 10 078



	SDK 300	SDAK 400
	Article number	Article number
Version: Standard steel S235JR	762 10 013	762 10 069
Version: Stainless steel 1.4301 (1.4571 on request)	762 10 023	762 10 070
Version: Standard steel S 235JR with exhaust air pipe	762 10 024	762 10 071
Version: stainless steel 1.4301 (1.4571 on request) with exhaust air pipe	762 10 025	762 10 072
Version: Standard steel S235JR ATEX 20/22	762 10 074	762 10 073
Version: Stainless steel 1.4301 (1.4571 on request) ATEX 20/22	762 10 174	762 10 173

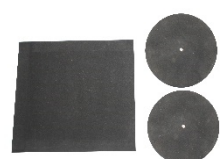

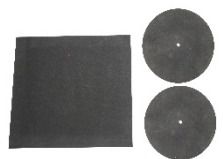



	Weld in flange SDAK 150 / 300	Weld in flange SDAK 400
	Article number	Article number
Version: Standard steel S235JR	762 10 004	762 10 079
Version: Stainless steel 1.4301 (1.4571 on request)	762 10 104	762 10 179
Version: Aluminum	762 10 080	762 10 180

Options	SDAK XXX	
	Article number	
Limit switch incl. sensor S235JR 24V/DC, IG5533 added, open cable ends 1 piece	881 10 084 SDAK 150: V1 SDAK 300 / 400: V2	
Limit switch incl. sensor S235JR 230V/AC/Allstrom, IG6006 added, open cable ends 1 piece	881 10 057 SDAK 150: V1 SDAK 300 / 400: V2	

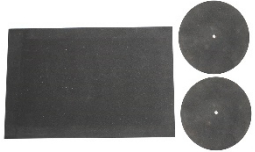
Equipment / spare parts

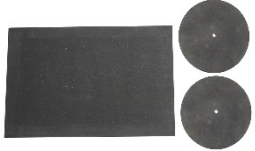

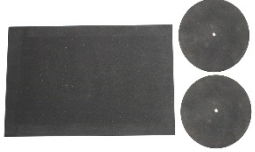

SDAK 150		
	Article number	
Gasket set for SDAK 150 without exhaust air pipe	762 10 006	
Rubber buffers for SDAK 150	721 10 043	
Gasket set antistatic (ATEX) for SDAK 150 without exhaust air pipe	762 10 055	
Gasket set silicone for SDAK 150 without exhaust air pipe	762 10 039	

Gasket set silicone for SDAK 150 with exhaust air pipe	762 10 039-01	
Rubber buffers food safe for SDAK 150	762 10 021	

SDAK 300		
	Article number	
Gasket set for SDAK 300	762 10 016	
Gasket set antistatic (ATEX) for SDAK 300 	762 10 090	
Gasket set silicone for SDAK 300	762 00 043	
SDAK 400		
Gasket set silicone for SDAK 400	762 10 175	
Gasket set antistatic (ATEX) for SDAK 400 	762 10 176	

Examples – individual special solutions:

Over pressure / Vakuum flaps	Article number	
SDAK 150 without exhaust air pipe	766 10 003	
SDAK 150 VA upto 250°C ATEX temperature 250°C and ATEX 20/22 	762 10 083 - 01	
SDAK 400 double levers stainless steel with exhaust air flange	762 10 072	
Over pressure flaps only		
SÜDK 150 single lever with exhaust air pipe DN 200 Stanelle connection flange	762 10 062	
SÜDK 150 with exhaust air pipe DN 200 connection flange DN 200	767 10 060	

Vacuum flaps only		
UDK 150 with air inlet	751 10 307	
UDK 150	762 10 089	
UDK 150 – ATEX 20/22 	762 10 089-01	

AVOIDS OVERFILLING OF SILOS

When filling silos with dusty materials using a pneumatic filling device it often occurs that silos are overfilled. This can cause dramatic damages not only to the property (e.g. blown of silo roof tops, damaged filters, etc.) but also to people. That is why Stanelle developed various systems and components in order to avoid such accidents. When designing and constructing such security systems for pneumatically filled silos it is extremely important to focus on a lockable fill pipe as well as protection against overfilling. Furthermore a fully automatic dedusting of filters plus a end slosh limitation should be installed within the silo system. In addition to these components a Stanelle filter system with adequate filter material guarantee to meet TA-air demands, reduce dust emissions to a minimum and protect personal and property from damages.

It is absolutely necessary to protect the piping from being filled with outside contaminants. This is ensured through installing a filling pipe gate bracket which is sealed by an additional lock. The keys to the silos filled with different materials cannot be interchanged, which inhibits wrong filling of the silos.

When vehicles connect their fill tube to the silo, the mechanical end switch of the fill pipe gate bracket automatically actuates the filter dedusting. The same effect of filter dedusting kicks in when the fill tube is disconnected.

Inside the silo roof a single operating fill indicator is installed which can be adjusted to any fill material. Furthermore the fill height which depends on the silo diameter and the fill pipe volume can be tuned individually. If the fill level reaches the indicator, a clear acoustic signal informs workers that the fill pipe will be automatically closed down with 30 to 60 seconds. The filling process is interrupted and the fill pipe is emptied out or the pinch valve closes. After the pinch valve is closed, conventional semi-automatic bunker dedusting filters are automatically cleaned. During the filling phase of the silo the pinch valve can be opened with a switch in order to blow out the fill pipe. If the fill tube of the silo vehicle is not locked correctly after finishing of with the filling than the pressure inside the silo reaches critical levels due to the end splash. Dust leaks out of the over pressure protection of the silo and diffuses into the surrounding. To avoid this danger, pressure switches are built into the silo roof. As soon as the critical level is reached, the pinch valve temporarily closes and the filter cleaning kicks in automatically. Afterwards the outlet opens automatically and the filling process can continue up to a maximum level. If this level is reached the pinch valve stays locked until the indicator is cleared again.



Areas of Application

Monitoring the filling process avoids damages to persons and property!

**Details / Explanation
Component I**

➤ **Segment I**

1 control panel made of steel plates with built in electronics,
signal-lamp „green“ indicating „operating status“
signal-lamp „red“ indicating „silo is full“
signal-lamp „white“ indicating pinch valve opened
volume of acoustic signal horn about 90 dB (A) and pressure switch,
Connection voltage 220/380 V 50 Hz

1 Pinch valve with fixed clutch and 3/2-ways-magnet outlet 220 V 50 Hz, cover for magnet outlet and operating sign

1 m long cable sensor for cement or similar materials without electronic wiring and installation.

➤ **Accessory 1:**

External signal-lamp „green“ and „red“ with horn and bracket to mount to the fill pipe.

➤ **Accessory 2:**

Bracket to mount the control box on top the fill pipe

The “green” and “white” signal-lamp indicate that the silo system is in operation mode and ready to be filled. As soon as the critical fill level is reached, the cable sensor responds, the signal-lamp switches to “red” and the horn resounds for 10 seconds. The fill process ends and the fill pipe is blown out. After additional 30 to 60 seconds (adjustable) the pinch valve closes automatically (“white” signal-lamp goes out) and stays closed until the cable sensor is not fully covered with material anymore.

**Functionality
Component I**

A pressure switch guarantees the possibility to open the pinch valve after the cable sensor has responded.

Emergency Opener

The activation of the pressure switch can cause damage to the silo due to overfilling. The “green” signal-lamp goes out and therefore indicates that the silo system is not ready to operate, whereas the fill pipe can still be blown out in the meantime.

Attention



**Details / Explanation
Component II**

➤ **Component II**

Semi-automatic filter control

to dedust the filter clothes and filter cartridges using a pressure switch and automatic shutoff.

Fully automatic filter control

to dedust the filter clothes and filter cartridges using the fill pipe gate bracket mounted to the pinch valve.

„Semi-automatic“ variant

The process of cleaning filters with out-of-balance engines is started through a switch. The dedusting process automatically stops after 30 seconds. As soon as the lock switch is activated the dedusting process automatically starts, whereas the pinch valve is closed to prevent any material inflow.

**Functionality
Component II**

„Fully automatic“ variant

When fill tubes are connected or disconnected, the mechanical end switch of the fill pipe gate bracket automatically actuates the filter dedusting. This guarantees that filter clothes and filter cartridges are cleaned before and after every filling process and a damage to the filter cake caused by humidity is prevented.

**Details / Explanation
Component III**

➤ **Component III**

„Final splash limitation“

through pressure switch, only in connection with the filter control. When pressure increases, the pressure switch closes the pinch valve temporarily and filter clothes and filter cartridges are dedusted. The pinch valve opens after 30 seconds again and the fill pipe can be fully blown out or the next filling process can begin.

The installation of this component only makes sense combined with component II.

Through a pressure sensor mounted to the silo roof the pinch valve closes automatically when critical levels are reached and the filter is dedusted automatically. The final splash limitation inhibits any damage to the silo in case of too much inflow of air during the filling process or insufficient maintenance of the filter. If the final splash limitation kicks in too often during the filling process than the conveying air pressure has to be lower; if necessary filter clothes or filter cartridges have to be replaced.

**Functionality
Component III**

Technical Data Overfill Protection

NW	80	100	125	150
Max. temperature	80° C			
Solenoid valves / pieces	1			
Operating pressure	2 bar, over conveying air pressure max. 6 bar			
Compressed-air connection / mm	ø 9			
Voltage	230 VAC			

Variable voltages can be tailored to your special application!

Notice



Article Number

NW 80	Component I	Component II	Component III
Article number	732 10 017	881 10 147	732 10 016

Article Number

NW 100	Component I	Component II	Component III
Article number	732 10 015	881 10 147	732 10 016

Article Number

NW 125	Component I	Component II	Component III
Article number	732 10 019	881 10 147	732 10 016

Article Number

NW 150	Component I	Component II	Component III
Article number	732 10 020	881 10 147	732 10 016

Additional sizes and options (e.g. Ex-proof version) can be tailored to your special application!

Notice



When placing an order please define the materials which are mixed in your silo system (e.g. cement, lime etc...)

MAXIMUM LEVEL SENSOR

UNIVERSAL VIBRATION LIMIT SWITCH FOR FINE GRAINED BULK MATERIALS.



For dust explosion
imperiled areas on
application

This vibration limit switch is a robust fill level sensor for silos with grained or dusty bulk cargos, even if they have a very low piled weight. The different construction designs allow various areas of application, also in dangerous dust explosion areas of the zone 20 or in foodstuffs.

Areas of Application

- No compensation, fast and low-cost start of operation.
- Non-sensitive to crust building, maintenance-free operation.
- No mechanically moved parts, no abrasion, long durability.
- Various electronic applications, optimal adaptation into the system control.
- Body with clear cover, switching status display recognizable from outside, easy to control.
- Aluminum body with separated connection space, also for protection model EEx de
- Plastic, high-grade steel 1.4571 or aluminum.

Details / Explanation

Body Finish

Installation

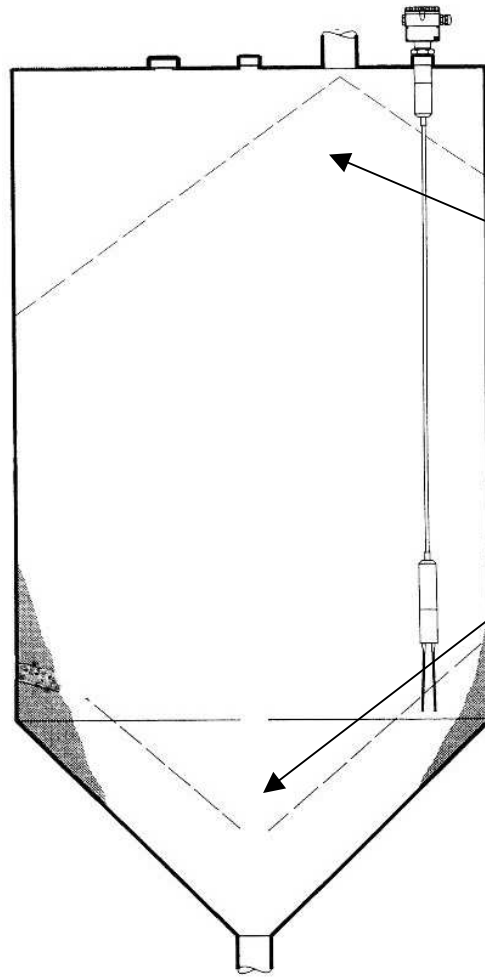

When calculating the necessary cord length, the angle of driving slope of the angle of repose or the haul-off hopper have to be considered.

To keep the tensile load low, the installation is done next to the silo barrier, but not too close, so that the sensor does not hit the wall if it swings.

Functioning

The symmetrical swing fork is stimulated on its resonance frequency. If it dives into bulk cargo, the swing character changes, and the electronic activates either an electronic switch or a relays. On top of the swing fork the vibrating limit switch is extremely sensitive which allows a minimum detection level in bulk materials with very low plied density. At the swing fork root however, the vibrating limit switch is non-sensitive, as a result crust building on the container wall does not influence the proper function. The vibrating limit switch can be operated in minimum or maximum standby current protection, which means when reaching the minimal or maximal fill level, filling errors or power failure the electronic switch locks up or the relay drops down.

Technical Data

Vibration limit switch	
Functioning	Absorbing of the swinging of a self-resonance swinging oscillating fork.
System structure	Complete fill level limit switch, consisting of measuring type probe with pre-installed electronic application (switch gear).
Signal processing	Two-wire-alternating current specification. Switching the demand over a thyristor directly in the supply unit electric system. Three-wire-continuous current specification. Switching the demand over a transistor and a separate connection. All current specification with relay output. Switching the demand over a potential-free change-over contact.
Galvanic isolation	Between measuring sensor and emergency current
Measured variable, metering range	Filling level (threshold, binary), given through length of the probe (rope) given (circa. 800 ...20000 mm from top).
Output signal	Binary; when reaching the threshold outlet blocked.
Safety switch	Minimum – or maximum – standby current security, switchable.
Response time	Ca.0,5 s at covering, ca.1,5 s at release. Switchable to ca. 2,5 s at covering, ca.7,5 s at release.
Precision of measurements at a temperature T =20 °C, operating pressure p =1 bar, piled density of the bulk material >1 kg/l, grain size <2 mm	Error of measurement: Ca.10 mm at vertical installation, 5mm at sideways installation of the probe. Settling time: After activating the emergency current the outlet keeps blocked for ca. 2,5 s. Response time variation: +/- 25 % at covering or release. Influences of temperature and operating pressure: insignificant.
Ambient temperature	-40 °C ...+70 °C
Type of protection (body)	IP 66 after DIN 40050
Temperature of measuring material	-40 °C ...+150 °C
Piled density of measuring material	min.20 g/l
Grain size of measuring material	up to 10 mm
Process connections	Conical thread R 1 ½ after DIN 2999 part 1.
Electronic connection	Screw clamps on the electronic application for maximum 2,5 mm ² cord. In end splice A 2,5 -7 after DIN 46228. Screw clamps in a separate connection space for aluminum bodies with plastic coating. For max.2,5 mm ² cord in end splice A 2,5 -7 after DIN 46228.
Operation display surface	Rotary switch for change-over of the minimum and maximum safety switching. Red illuminating diode for displaying the status.

Article number

Vibration limit switch	
	Article number
	731 10 047

MAXIMUM LEVEL SENSOR

CAPACITIVE LIMIT LEVEL DETECTION COMPACT FILLING LEVEL LIMIT SENSOR WITH INTEGRATED ACTIVE OUTLET COMPENSATION.

For dust explosion
imperiled areas on
application

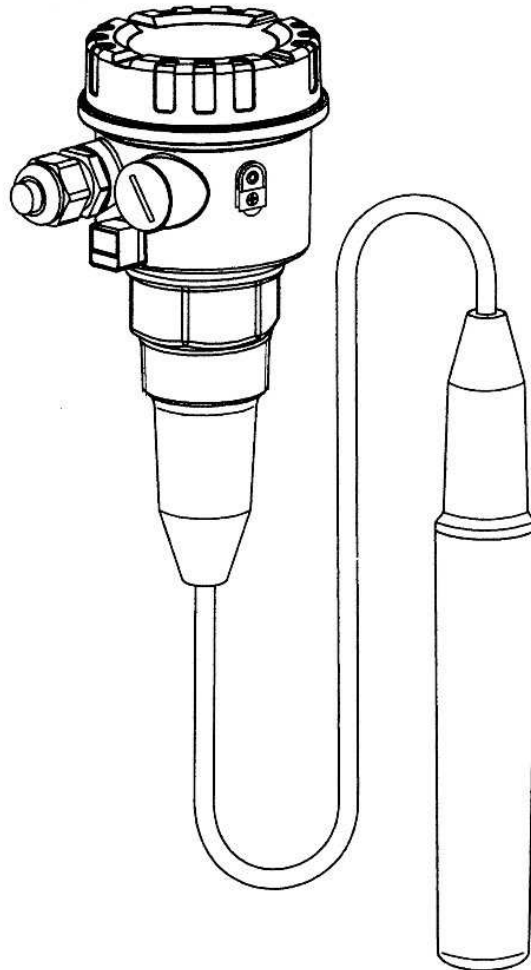

This filling level sensor is used for limit level detection in light bulk materials, e.g. crop, wheat, milk powder, mixed feed, cement, chalk or hard plaster.

Areas of Application

- Easy installation; you can start operating without calibration
- Integrated, active beginning compensation, thereby exact switching point also at heavy crust building on the sensor and high operational safety.
- No abrasion, long durability, maintenance-free.
- Various electronic applications, optimal adjustment to the system control.
- Rope sensor can be shortened, thus optimal adjustment to the metering point in the silo and easy storage.

Details / Explanation

- Polyester, IP 66

Body Finish

Installation

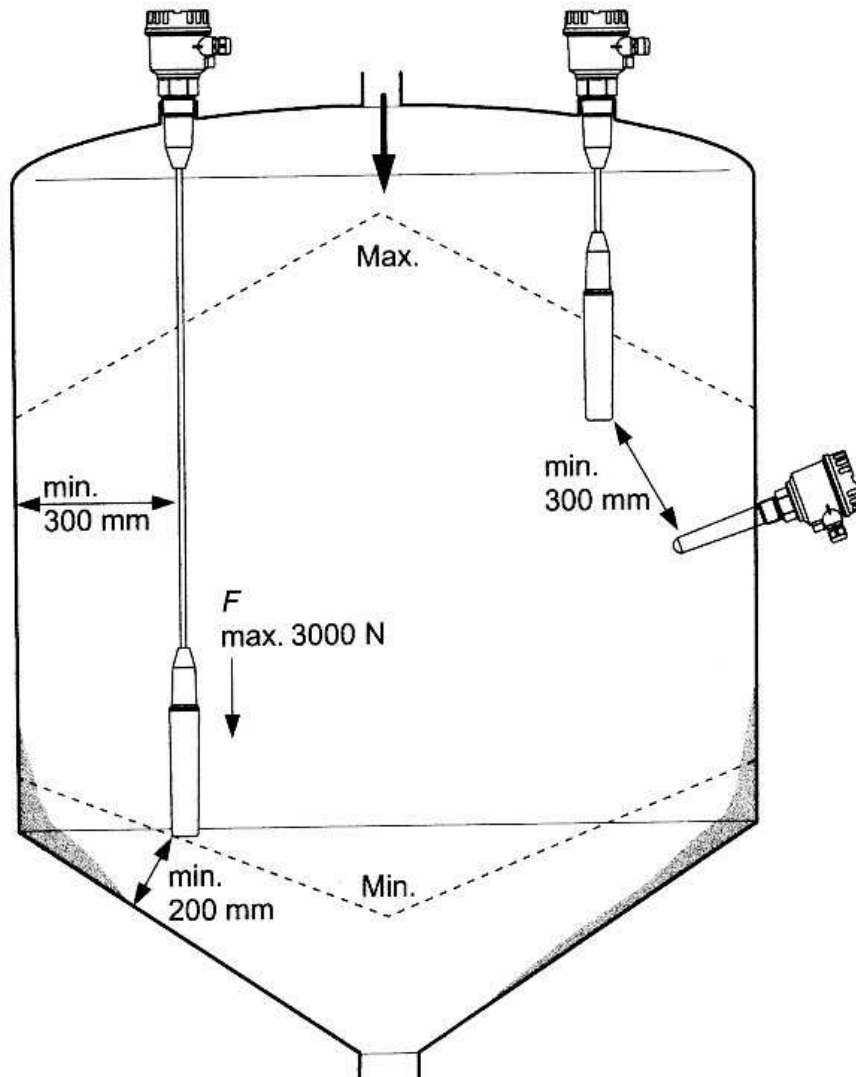

When calculating the optimal wire length, the angle of driving slope of the angle of repose or the haul-off hopper has to be considered.

Pay attention that enough space is left to feed materials and to the next sensor. The installation area must not be in the centre of the drain outlet cone. Instead there should be a good distance to the silo wall and to the material beginning on the silo wall respectively.

A metal plate mounted to the end part of the sensor, the isolation and the environment (e.g. the silo wall) form both electrodes of a condenser. If bulk cargo covers or releases the sensor, the limit switch of capacity and filling level shifts.

Functioning

The filling level limit switch recognizes crust building on the sensor and compensates the influence so that the shift point is always kept at exactly the same levels. The execution of the beginning compensation is dependent on the thickness of the crust on the sensor as well as the conductivity of the sensor pad and the sensitivity settings made electronically. This setting is alternately adjusted so that it switches precisely in most of the cases. Another way to adjust sensitivity is to change the multipolar switch on the electronic application. This is only required when heavy crust builds on the sensor or at very low relative permittivity ϵ_r of the bulk material. A correlation between relative permittivity ϵ_r and bulk density ρ of the bulking material can be recognized, but this correlation varies depending on the bulk material.

Scale drawing

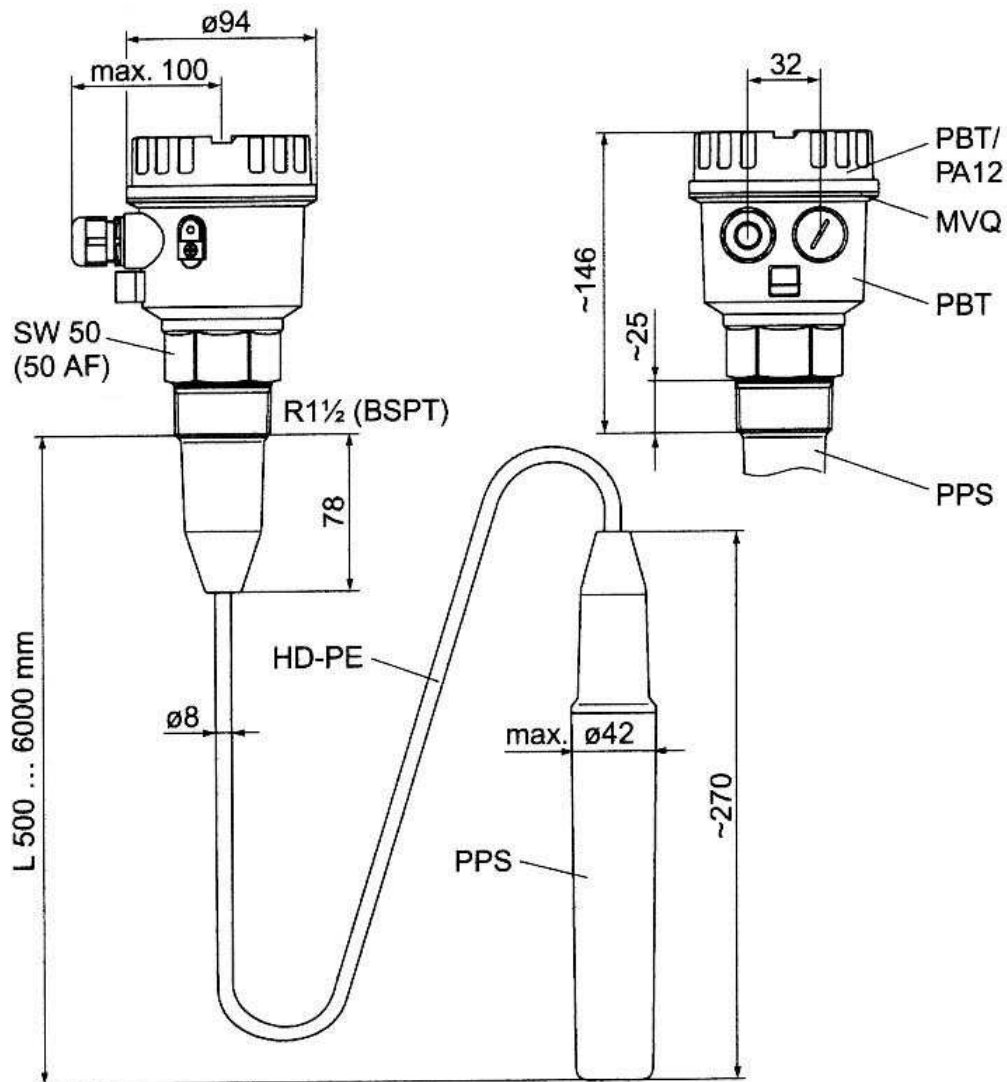

Tolerance of sensor depending on its length:

Length of Sensor L	Tolerance
up to 1000 mm	+0, -10 mm
up to 3000 mm	+0, -20 mm
up to 6000 mm	+0, -30 mm

Technical Data

Capacitive filling level limit detection	
Functioning	Capacitive
System structure	Compact device with sensor on rope, binary signal transmission.
Metering range	$\epsilon_r \geq 1,5$
Electronic application	With continuous current PNP-transistor exit, with continuous current/ alternating current relay output.
Output signal	Switch PNP: I_{max} 200 mA, overload / short-circuit protection, residual voltage on the transistor at $I_{max} < 2,9$ V. Contact change switch, potential-free: $U_{max} \sim 253$ V, $I_{max} \sim 4$ A $P_{max} \sim 1000$ VA, $\cos \varphi = 1$ $P_{max} \sim 500$ VA, $\cos \varphi > 0,7$ $I_{max} \sim 4$ A, bis $U_{\sim} 30$ V $I_{max} \sim 0,2$ A, bis $U_{\sim} 235$ V
Response time	At covering or release 0,8 s
Precision of measurements (for plastic container) at: Temperature T 23 °C Measuring material temperature 23 °C Measuring pressure $p_e = 0$ bar. Measuring material: Relative permittivity $\epsilon_r = 2,6$ Conductivity $< 1 \mu S$, setting sensitivity switch: C	Hysteresis: Vertical 5 mm Shift point: Vertical, 35 mm above sensor end Rising action: After max. 2 s correct shift setting Long-time drift: Vertical 6 mm Influence of measuring temperature: Depending on the filling material
Ambient temperature	-20 °C ...+70 °C, (...+60 °C dust ex-version)
Type of protection (body)	IP 66
Measuring material temperature	-20 °C ...+70 °C
Measuring material pressure limit	-1...+6 bar
Piled density of measuring material	min.200 g/l, $\epsilon_r \geq 1,6$
Grain size of measuring material	max. 30 mm
Process connection	Thread R 1 ½ after DIN 2999 BSPT.
Electrical connection	Screw clamp connection: For cord max. 1,5 mm ² . For wire max. 2,5 mm ² .
Operating display surface	Switch on the electronic application: Shift between min.- and max. security. Adjustment of sensitivity (dependent from relative permittivity ϵ_r and crust building). Normally, an adjustment of sensitivity is not necessary.

Article number

Capacitive filling level limit detection	
	Article number
	731 10 098

MINIMUM LEVEL SENSOR

UNIVERSAL VIBRATION LIMIT SWITCH FOR FINE GRAINED BULK MATERIALS.

**For dust explosion
imperiled areas on
application**



This vibration limit switch is a robust fill level sensor for silos with grained or dusty bulk materials, even if they have a very low piled weight. The different construction designs allow various areas of application, also in dangerous dust explosion areas of the zone 20 or in foodstuffs.

Areas of Application

Details / Explanation

- No compensation, fast and low-cost start of operation.
- Non-sensitive to crust building, maintenance-free operation.
- No mechanically moved parts, no abrasion, long durability.
- Various electronic applications, optimal adaptation into the system control.
- Body with clear cover, switching status display recognizable from outside, easy to control.
- Aluminum body with separated connection space, also for protection model EEx de
- Plastic, high-grade steel 1.4571 or aluminum.

Body Finish

Installation

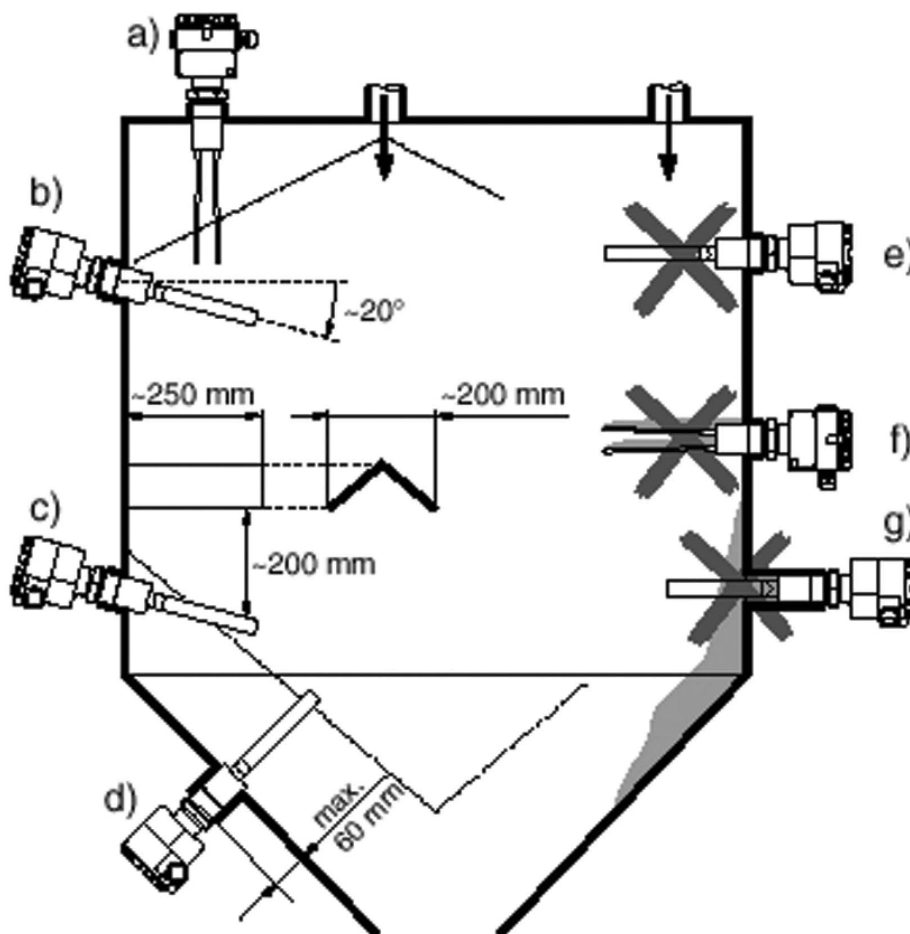

When calculating the necessary cord length, the angle of driving slope and the angle of repose or the haul-off hopper have to be considered.

See correct installation to the left side of the drawing:

- a) at a right angle from above; swing fork position arbitrary
- b) sideways, swing forks are slightly bend down so that bulk cargo can slip off easily
- c) With protection roof (length approx. 250 mm, width approx.200 mm) against collapsing overhangs.
- d) Max. socket length of 60 mm inside the hopper

See wrong installation to the right side of the drawing:

- e) directly in the stream of bulk material
- f) incorrect positioning of swing forks (high stress on the wide side of the swing forks through pressuring bulk material; malfunction due to congregation of bulk material)
- g) Too long screw-in socket

The symmetrical swing fork is stimulated on its resonance frequency. If it dives into bulk cargo, the swing character changes, and the electronic activates either an electronic switch or a relays. On top of the swing fork the vibrating limit switch is extremely sensitive which allows a minimum detection level in bulk materials with very low plied density. At the swing fork root however, the vibrating limit switch is non-sensitive, as a result crust building on the container wall does not influence the proper function. The vibrating limit switch can be operated in minimum or maximum standby current protection, which means when reaching the minimal or maximal fill level, filling errors or power failure the electronic switch locks up or the relay drops down.

Functioning

Scale drawing

Short construction,
with thread
R 1½ (DIN 2999)

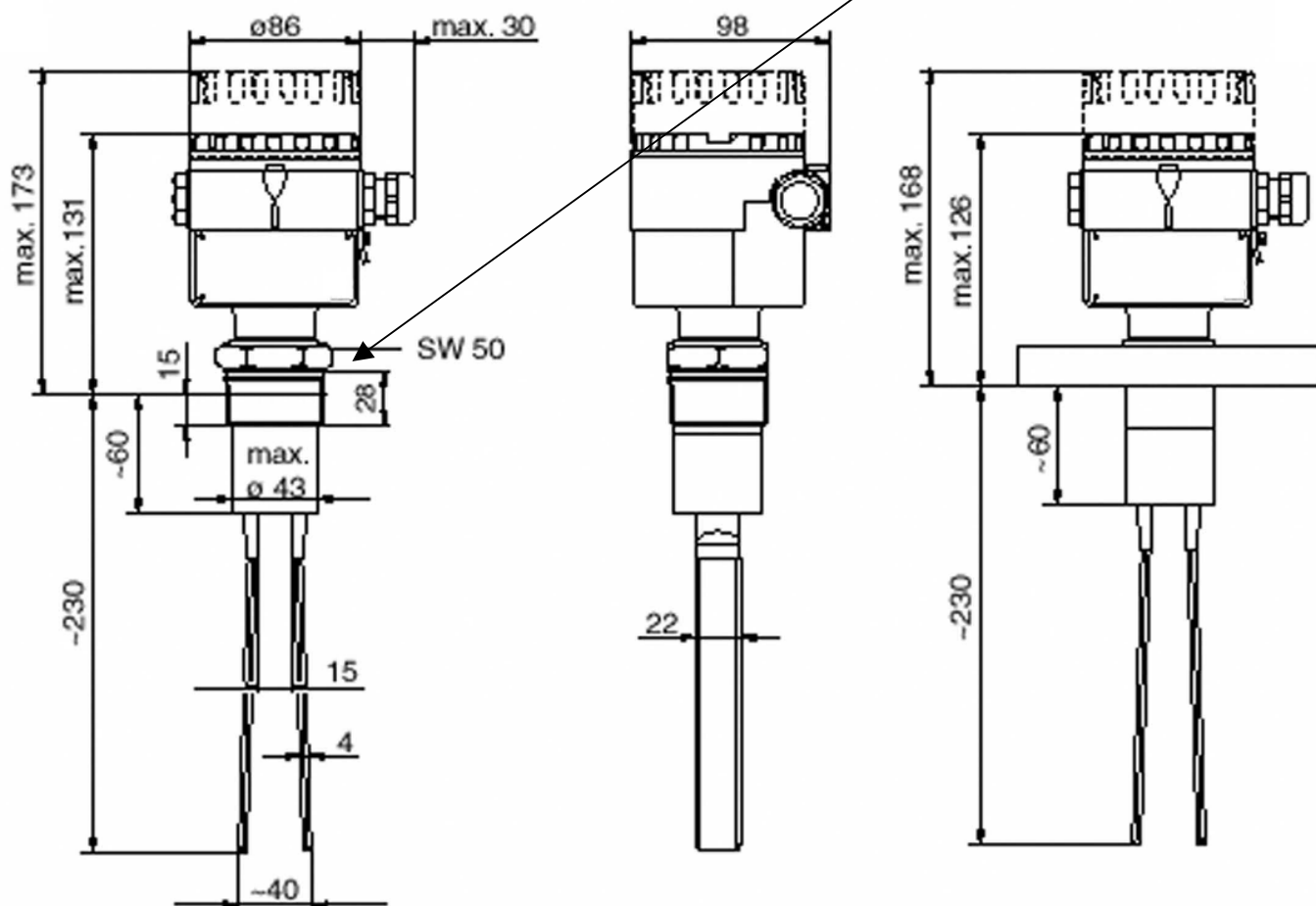

Technical Data

Vibration limit switch	
Functioning	Absorbing of the swinging of a self-resonance swinging oscillating fork.
System structure	Complete fill level limit switch, consisting of measuring type probe with pre-installed electronic application (switch gear).
Signal processing	Two-wire-alternating current specification. Switching the demand over a thyristor directly in the supply unit electric system. Three-wire-continuous current specification. Switching the demand over a transistor and a separate connection. All current specification with relay output. Switching the demand over a potential-free change-over contact.
Galvanic isolation	Between measuring sensor and emergency current
Measured variable, metering range	Filling level (threshold, binary), given through point of installation
Output signal	Binary; when reaching the threshold outlet blocked.
Safety switch	Minimum – or maximum – standby current security, switchable.
Response time	Ca.0,5 s at covering, ca.1,5 s at release. Switchable to ca. 2,5 s at covering, ca.7,5 s at release.
Precision of measurements at a temperature T =20 °C, operating pressure p =1 bar, piled density of the bulk material >1 kg/l, grain size <2 mm	Error of measurement: Ca.10 mm at vertical installation, 5mm at sideways installation of the probe. Settling time: After activating the emergency current the outlet keeps blocked for ca. 2,5 s. Response time variation: +/- 25 % at covering or release. Influences of temperature and operating pressure: insignificant.
Ambient temperature	-40 °C ...+70 °C
Type of protection (body)	IP 66 after DIN 40050
Temperature of measuring material	-40 °C ...+150 °C
Piled density of measuring material	min.20 g/l
Grain size of measuring material	up to 10 mm
Process connections	Conical thread R 1 ½ after DIN 2999 part 1.
Electronic connection	Screw clamps on the electronic application for maximum 2,5 mm² cord. In end splice A 2,5 -7 after DIN 46228. Screw clamps in a separate connection space for aluminum bodies with plastic coating. For max.2,5 mm² cord in end splice A 2,5 -7 after DIN 46228.
Operation display surface	Rotary switch for change-over of the minimum and maximum safety switching. Red illuminating diode for displaying the status.

Article number

Vibration limit switch	
	Article number
	731 10 083

MINIMUM LEVEL SENSOR

LOW COST VIBRATION LIMIT SWITCH FOR FINE GRAINED BULK MATERIALS.



Areas of Application

This vibration limit switch is a robust fill level sensor for silos with grained or dusty bulk materials, even if they have a very low piled weight. The different construction designs allow various areas of application e.g. foodstuffs.

- No compensation, fast and low-cost start of operation.
- Non-sensitive to crust building, maintenance-free operation.
- No mechanically moved parts, no abrasion, long durability.
- Various electronic applications, optimal adaptation into the system control.
- Body with clear cover, switching status display recognizable from outside, easy to control.

Details / Explanation

- Polyester.

Body Finish

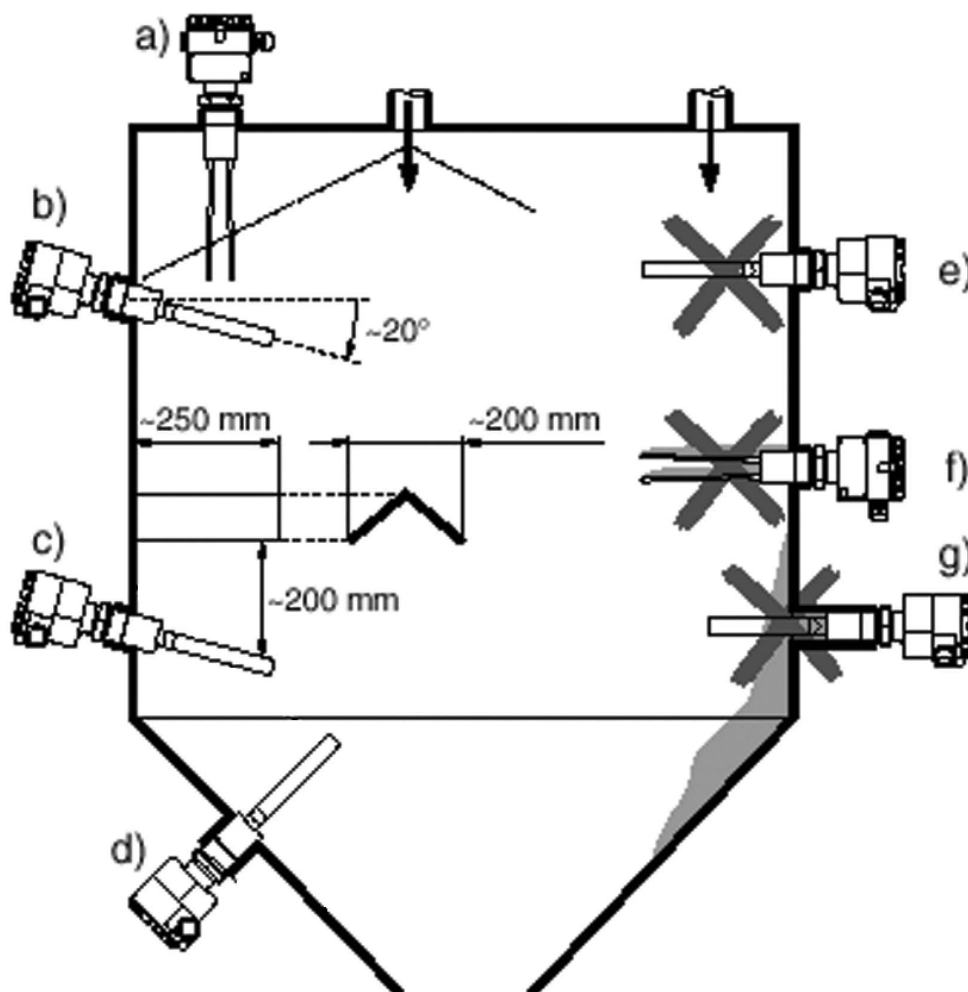

The vibration limit switch may be installed in any position according to the left side of the drawing.

See correct installation to the left side of the drawing:

- a) at a right angle from above; swing fork position arbitrary
- b) sideways, swing forks are slightly bend down so that bulk cargo can slip off easily
- c) With protection roof (length approx. 250 mm, width approx.200 mm) against collapsing overhangs.
- d) Max. socket length of 60 mm inside the hopper

See wrong installation to the right side of the drawing:

- e) directly in the stream of bulk material
- f) incorrect positioning of swing forks (high stress on the wide side of the swing forks through pressuring bulk material; malfunction due to congregation of bulk material)
- g) Too long screw-in socket

The symmetrical swing fork is stimulated on its resonance frequency. If it dives into bulk cargo, the swing character changes, and the electronic activates either an electronic switch or a relays. On top of the swing fork the vibrating limit switch is extremely sensitive which allows a minimum detection level in bulk materials with very low plied density. At the swing fork root however, the vibrating limit switch is non-sensitive, as a result crust building on the container wall does not influence the proper function. The vibrating limit switch can be operated in minimum or maximum standby current protection, which means when reaching the minimal or maximal fill level, filling errors or power failure the electronic switch locks up or the relay drops down.

Functionality

Scale drawing

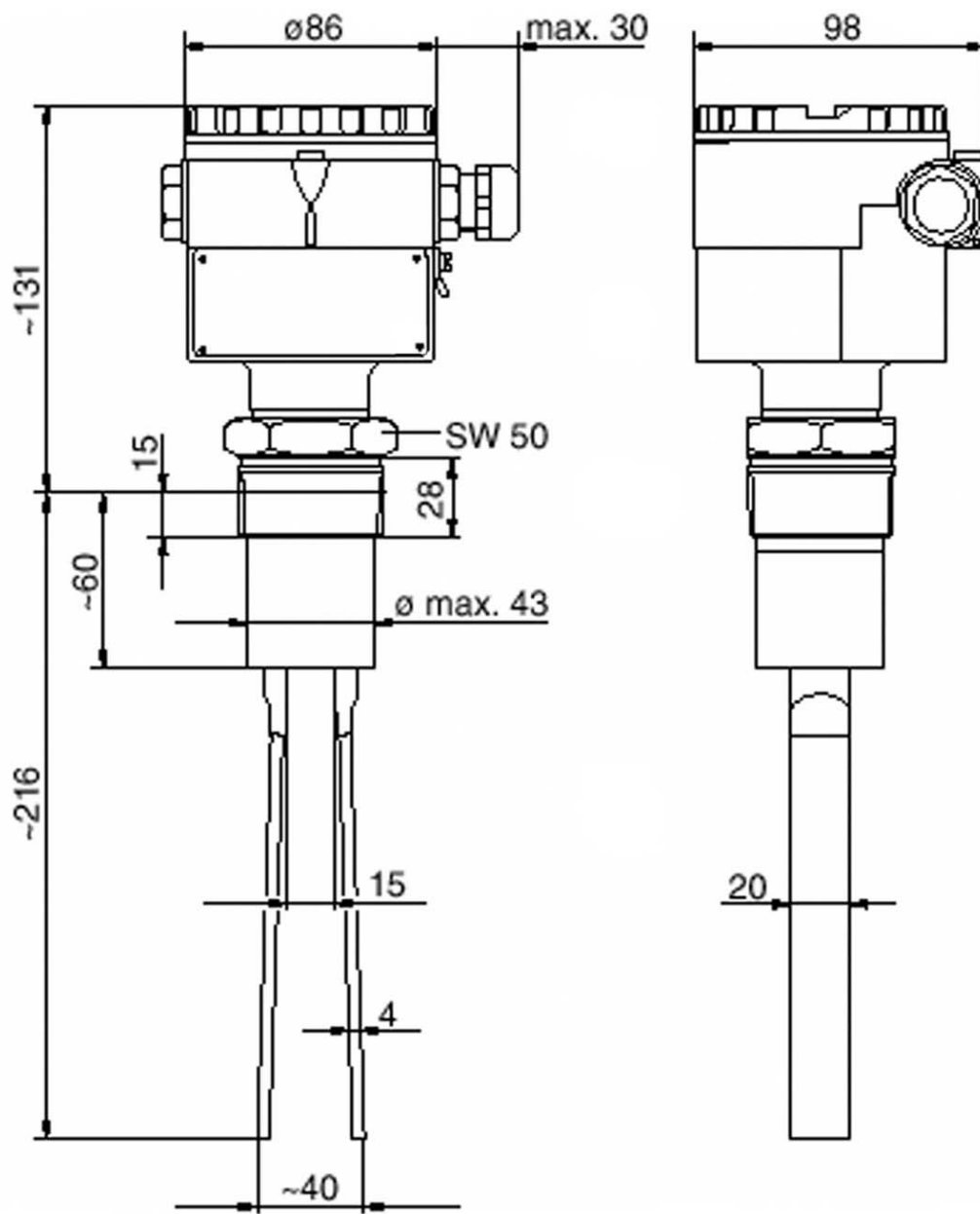

The clear cover allows a direct look at the light-emitting diode and the switch display

The plastic body, protection type IP 66, with various cable entry points.

Variants of process connection
 R 1½, DIN 2999,
 (conical)
 made of noncorrosive steel.

Swing fork made of massive non corrosive steel with high resistance to stress and pressure

Technical Data

Vibration limit switch	
Functioning	Vibration limit switch binary
System structure	Compact unit, electronic application pluggable
Signal processing	Two-wire-alternating current specification, always connect in series! Pay attention to fall of voltage at the electronic application when connect through design applies (up to 12 V), the residual current in locked up mode (up to 3,8 mA) and low connection voltage resulting in fall of voltage above the working resistance so that the tension does not fall below the minimum disk tension in the electronic application (19 V). Three-wire-continuous current specification, preferred in connection with stored-program controls (SPS). Positive signal at the relay switching output of the electronic application.(PNP) All current specification with relay output. Switching the demand over a potential-free change-over contact.
Safety switch	Minimum – or maximum – standby current security, switchable.
Response time	Ca.0,6 s at covering, ca.1,4 s at release.
Ambient temperature	–40 °C ...+70 °C
Type of protection (body)	IP 66 after DIN 40050
Temperature of measuring material	–40 °C ...+150 °C
Operating pressure	1 bar...+16 bar (burst pressure > 40 bar)
Piled density of measuring material	min.100 g/l
Grain size of measuring material	up to 10 mm
Process connections	Conical thread R 1 ½ after DIN 2999 part 1.
Electronic connection	Screw clamps on the electronic application for maximum 2,5 mm ² cord in In end splice A 2,5 - 7 after DIN 46228.
Operation display surface	Illuminating diode for displaying the status

Article number

Vibration limit switch	
	Article number
	731 10 100

MINIMUM LEVEL SENSOR

CAPACITIVE LIMIT LEVEL DETECTION COMPACT FILLING LEVEL LIMIT SENSOR WITH INTEGRATED ACTIVE OUTLET COMPENSATION.

For dust explosion
imperiled areas on
application



This filling level sensor is used for limit level detection in light bulk materials, e.g. crop, wheat, milk powder, mixed feed, cement, chalk or hard plaster.

Areas of Application

- Easy installation; you can start operating without calibration because unit exists of sensor and electric application
 - Integrated, active beginning compensation, thereby exact switching point also at heavy crust building on the sensor and high operational safety
 - No abrasion, long durability, maintenance-free.
 - Various electronic applications, optimal adjustment to the system control.
 - With pole sensor 140 mm.
-
- Polyester, IP 66

Details / Explanation

Body Finish

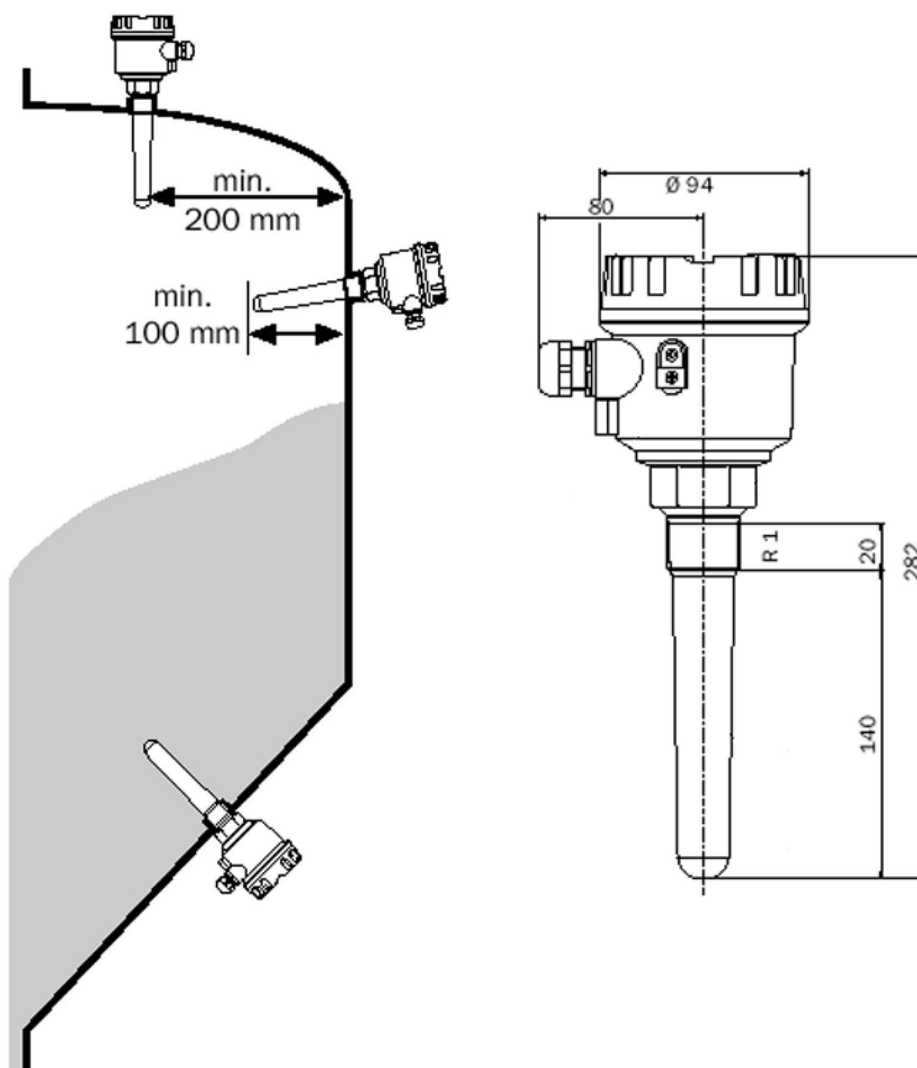

Installation / Scale Drawing

When deciding for an installation position the angle of driving slope of the angle of repose or the haul-off hopper have to be considered

The limit level detection is used within silos with bulk materials. The silos can be made of various materials (e.g. metal, plastic, concrete), because this does not affect the metering process.

This filling level limit switch is an electronic switch. When over or under filling the limit level a switch signal displays. A control device or various signals (lamps, horns, PLS, SPS, etc.) can be directly connected to the filling level sensor. The sensor possesses a built in switch for minimum/maximum level security. The sensor recognises crust building and compensates its influence so that the switching level always remains the same. The correct execution of the beginning compensation is dependent on the thickness of the crust on the sensor as well as the conductivity of the sensor pad and the sensitivity settings made electronically. The filling level sensor is factory-made calibrated and delivered. The device can be calibrated with various sensitivity settings. In order to operate safe and error-free, the filling level sensor has to be connected to a grounded silo with a metal or ferro concrete wall. When using silos made of insulating materials, the ground has to be connected to a conductive and grounded alternative nearby. A standard installation cable can be used as a connector.

Functionality

Technical Data

Capacitive filling level limit detection	
Functioning	Capacitive
System structure	Compact device with sensor on rope, binary signal transmission.
Metering range	$\epsilon_r \geq 1,6$
Electronic application	With continuous current PNP-transistor exit, with continuous current/ alternating current relay output.
Output signal	Switch PNP: I_{\max} 200 mA, overload / short-circuit protection, residual voltage on the transistor at $I_{\max} < 2,9$ V. Contact change switch, potential-free: $U_{\sim \max}$ 253 V, $I_{\sim \max}$ 4 A $P_{\sim \max}$ 1000 VA, $\cos \varphi = 1$ $P_{\sim \max}$ 500 VA, $\cos \varphi > 0,7$ $I_{\sim \max}$ 4 A, bis U_{\sim} 30 V $I_{\sim \max}$ 0,2 A, bis U_{\sim} 235 V
Response time	At covering or release 0,5 s
Precision of measurements (for plastic container) at: Temperature T 23 °C Measuring material temperature 23 °C Measuring pressure $p_e = 0$ bar. Measuring material: Relative permittivity $\epsilon_r = 2,6$ Conductivity $< 1 \mu\text{S}$, setting sensitivity switch: C	Hysteresis: Horizontal: 4 mm, Vertical: 7 mm Shift point: Horizontal: Middle of the sensor -5 mm, Vertical: 40 mm above sensor end Rising action: After max. 1,5 s correct shift setting Long-time drift: Horizontal: 3 mm, Vertical: 6 mm Influence of measuring temperature: Depending on the filling material
Ambient temperature	-40 °C ...+70 °C, (...+60 °C dust ex-version)
Type of protection (body)	IP 66
Measuring material temperature	0 °C ...+70 °C
Measuring material pressure limit	-1...+25 bar
Piled density of measuring material	min.200 g/l, $\epsilon_r \geq 1,6$
Grain size of measuring material	max. 30 mm
Process connection	Thread R 1 after DIN 2999 BSPT.
Electrical connection	Screw clamp connection: For cord max. 1,5 mm ² . For wire max. 2,5 mm ² .
Operating display surface	Switch on the electronic application: Shift between min.- and max. security. Adjustment of sensitivity (dependent from relative permittivity ϵ_r and crust building). Normally, an adjustment of sensitivity is not necessary.

Article number

Capacitive filling level limit detection	
	Article number
	731 10 101

PNEUMATIC DISCHARGE DEVICE AIR INJECTOR LOOSENING SYSTEM

The air injector loosening system is used to fluidize lazy flowing, technically dry, non-sticky, powdery products. The advantage of the air injector loosening system is that the injectors are not located directly in the stream of bulk material and **can be replaced from the outside**. Use in a series of pulses while discharging material is recommended.

Areas of Application

- 3, 4 or 6 special injectors with check valve, for installation into silo cone.
- Plastic reinforced tube, filter pressure reducing unit, assembled solenoid valve with mounting clamp for installation on silo cone or silo bracket
- The pre cleaned air (max. operating pressure of 5 bar) is connected on site to the strainer with a suitable tube. The air flows through the oil and water separator into the pressure reducing unit which throttles the air pressure to the necessary level. By activating the solenoid valve, the compressed-air flows through the plastic reinforced tube to the check valves, which are located directly in front of the air injectors, to finally fluidize the bulk material.
- With on site mounted maintenance unit.

Details / Explanation

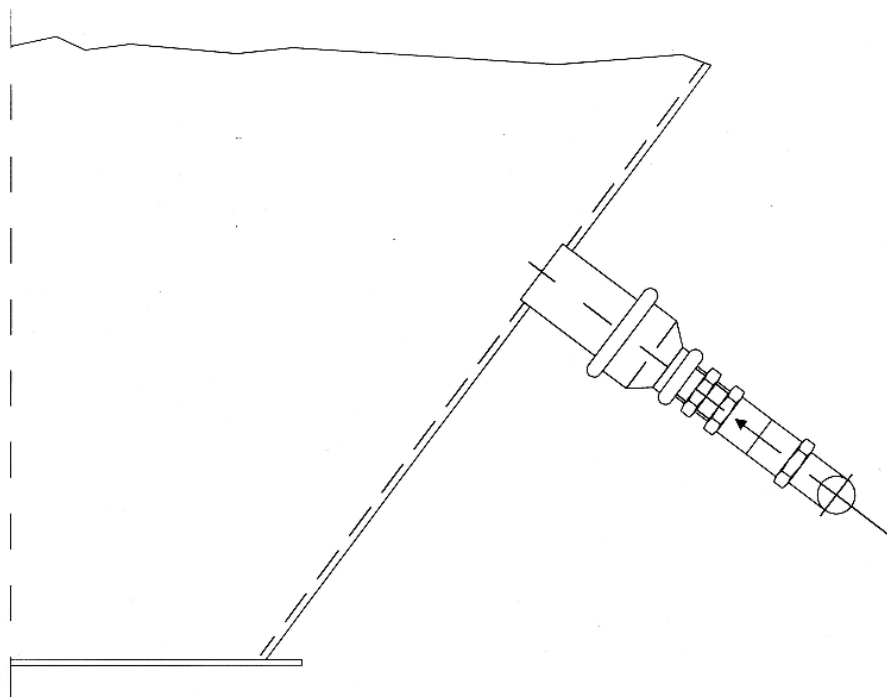

Installation of the air injectors

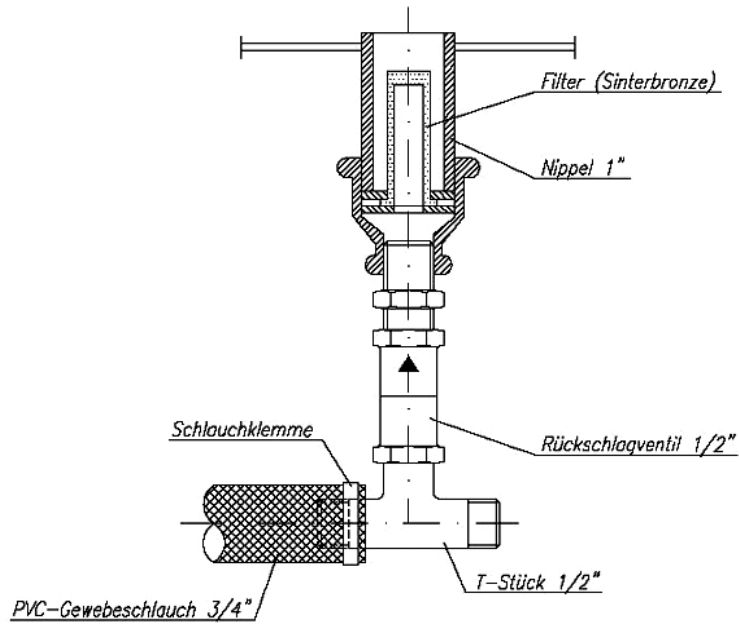

Scale drawing

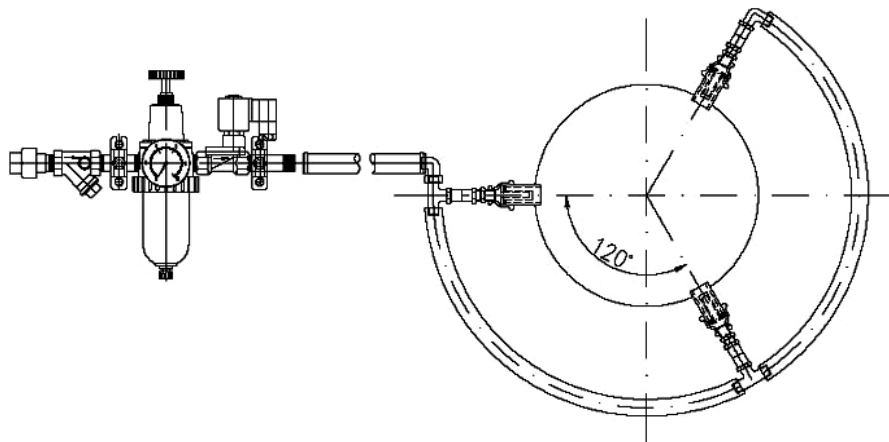

Scale drawing
With 3 injectors

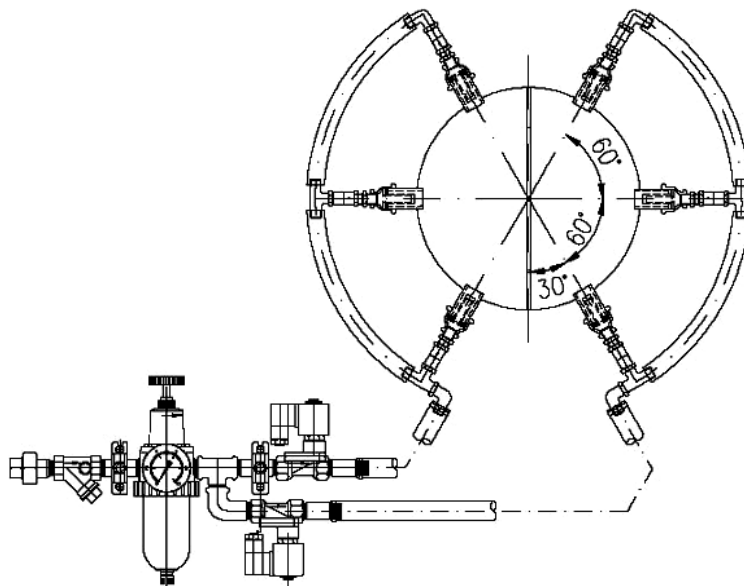

Scale drawing
With 6 injectors

Technical Data

Number of injectors	3	4	6
Air consumption at 1,5 bar	150 Nltr. / min.		
Operating pressure	1,2 – 2 bar		
Volume flow per injector	ca. 50 ltr. / min.		
Max. temperature strain	80° C		
Number of magnet valves	1		2
Connector	G ½"		
Pulse duration	5 – 7 sec.		
Pause	ca. 10 sec.		
Air	Technical dry, oil and foreign substance free		
Voltage on magnet valve	230 VAC		

Air and electrical input lead, compressor and fan are not included.

Notice



Article number

Number of injectors	3	4	6
Article number	742 10 010	742 10 041	742 10 035

Article number

Number of injectors	3	4	6
Accessories: clock relay			
Article number	881 10 007	881 10 007	881 10 007

Clock relay in plastic body IP 54, 230V 50Hz, for on site installation

Notice



PNEUMATIC DISCHARGE DEVICE AIR CUSHION LOOSENING SYSTEM



The air cushion loosening system is used for fluidination of lazy flowing, technically dry, non-sticky, powdery products. Use in a series of pulses while discharging material is recommended.

Areas of application

- 3, 6, 9 or 12 special cushions with check valve, for installation in to a silo cone
- Plastic reinforced tube, filter pressure reducing unit, assembled solenoid valve with mounting clamp for installation on a silo cone or silo bracket
- The pre cleaned air (max. operating pressure of 5 bar) is connected on site to the strainer with a suitable tube. The air flows through the oil and water separator into the pressure reducing unit which throttles the air pressure to the necessary level. By activating the solenoid valve, the compressed-air flows through the reinforced plastic tube to the check valves, which are located directly in front of the air injectors, to finally fluidize the bulk material.
- With on site mounted maintenance unit.

Details / Explanation

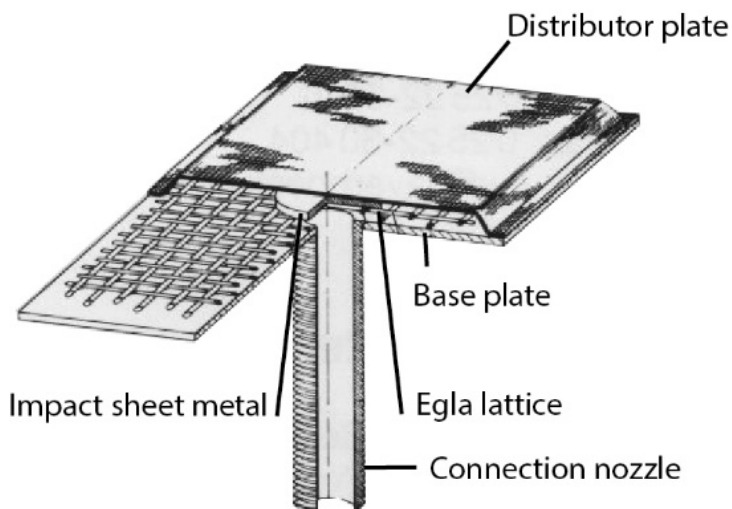

Scale drawing

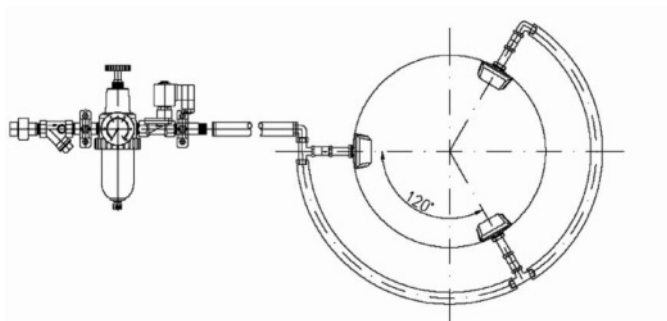
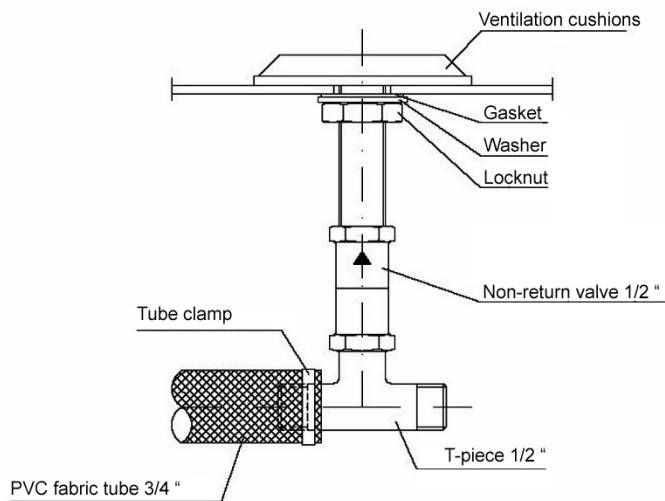

Version with
3 cushions

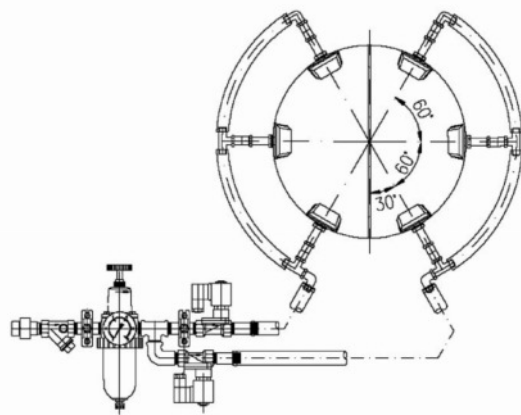

Version with
6 cushions

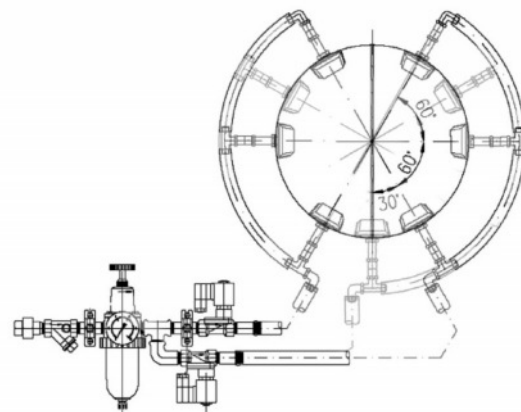

Version with
9 cushions

Technical data air cushion loosening system

Number of cushions	3	6	9	12
Air consumption at 1.0 bar / 5 sec. on / 10 sec. off	360 Nltr. / min.			
Operating pressure	0,5 – 1,0 bar			
Max. temperature cushion	up to 600°C			
Max. temperature cushion load ring line	80° C, higher temperatures on request			
Solenoid valves / pcs.	1	2	3	4
Connection	G ½"			
Size	100 mm x 200 mm			
Pulse duration	5 – 7 sec.			
Break	approx. 10 sec.			
Air	technically dry, oil-free and without foreign matter			
Voltage solenoid valves	230 VAC			

Physical Data

- Chrome nickel steel 1.4301, AISI 304.
- Max. operating temperature of 600° C.

Material grade

Air and electrical supply line, blower and compressor are not included in the scope of delivery.

Notice



Article number – complete systems

Number of cushions	3	6	9	12
Article number 12 mµ	742 10 016	742 10 042	742 10 067	742 10 069
Article number 40 mµ	742 10 014	742 10 036	742 10 068	742 10 070

Clock control STL up to 4 solenoid valves	3/1	6/2	9/3	12/4	
	Article number				
230V/DC Supply voltage	881 10 229				
24V/DC supply voltage	881 10 229-01				
Supply voltage 24V/DC ATEX Zone 22 	881 10 321				

Equipment / Spare parts

	Article number	
Cushion 12 mμ incl. seal and nut	742 10 020	
Cushion 40 mμ incl. seal and nut	742 10 019	
End piece	ST0713	
T-piece	ST2312	
Tube and T-piece	ST0191 ST2312	
Non-return valve	804 10 002	
Air hose transparent per meter	ST2176-PVC	
Solenoid valve 24V/DC	881 10 130	
Solenoid valve 230V/AC	881 10 087	
Solenoid valve ATEX 24V/DC with 3m cable	881 10 087	
Service unit for air injector loosening system complete, 230V/AC, with 1 solenoid valve	742 20 001	

<p>Service unit for air injector loosening system complete, 24V/DC, with 1 solenoid valve</p>	<p>742 20 002</p>	
<p>Service unit for air injector loosening system complete, 24V/DC ATEX 3D, with 1 solenoid valve</p>	<p>742 20 003</p>	
<p>Service unit for air injector loosening system complete, 230V/AC, with 2 solenoid valves</p>	<p>742 20 004</p>	
<p>Service unit for air injector loosening system complete, 24V/DC, with 2 solenoid valves</p>	<p>742 20 005</p>	
<p>Service unit for air injector loosening system complete, 230V/AC, with 3 solenoid valves</p>	<p>742 20 006</p>	
<p>Service unit for air injector loosening system complete, 24V/DC, with 3 solenoid valves</p>	<p>742 20 007</p>	
<p>Service unit for air injector loosening system complete, 24V/DC, with 4 solenoid valves</p>	<p>742 20 008</p>	
<p>Service unit for air injector loosening system complete, 24V/DC ATEX 3D, with 2 solenoid valves</p>	<p>742 20 009</p>	

**PNEUMATIC DISCHARGE DEVICE
PULSATOR LOOSENING SYSTEM**

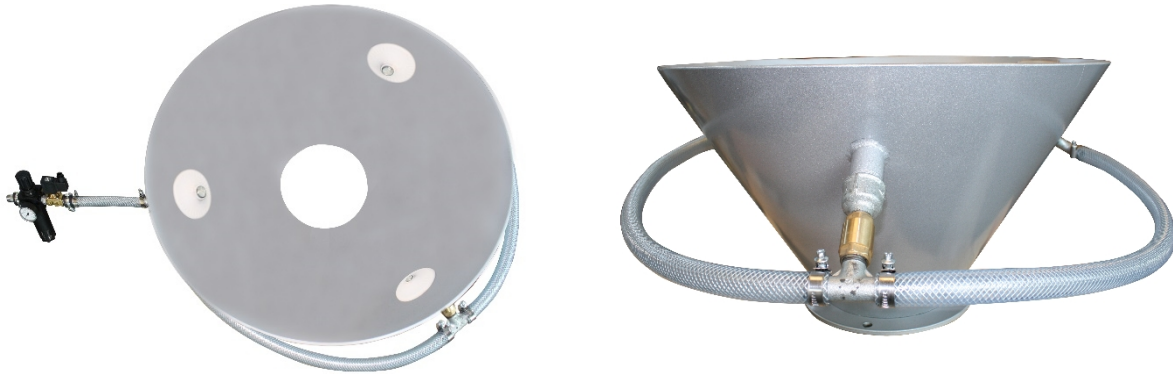

PL3 with ring set, magnet valve, service unit (built into the silo cone)

The pulsator loosening system is used to fluidize lazy flowing, technically dry, non-sticky, powdery products. Use in a series of pulses while discharging material is recommended.

Areas of Application

Dosed air fluidizes/ventilates the bulk material and additionally generates resonant, vibrating waves which support the flow of the bulk material. The Fluidisation of bulk product takes place along the silo wall. The pulsator sleeve with double sealing lip and a non-return valve prevents the product from flowing back into the compressed air network. The extremely flat design allows a safe product discharge.

Details / Explanation

The pulsators are made of stainless steel 1.4305 (AISI 303) with a food-safe sleeve standard design made of silicone Ø 100 mm white or natural (max. 170°C). An EDPM cuff is also available where silicone cannot be used.

- 3, 6 or 9 special pulsators, for installation into silo cone
- Plastic reinforced tube, filter pressure reducing unit, assembled solenoid valve with mounting clamp for installation on silo cone or silo bracket
- The pre cleaned air (max. operating pressure of 5 bar) is connected on site to the strainer with a suitable tube. The air flows through the oil and water separator into the pressure reducing unit which throttles the air pressure to the necessary level. By activating the solenoid valve, the compressed-air flows through the plastic reinforced tube to the check valves, which are located directly in front of the air injectors, to finally fluidize the bulk material.
- With on site mounted maintenance unit
- Simple subsequent installation
- Rugged design
- High temperature range

Advantages



Pulsator as an single component

Pulsator with mounting set and mounting cable

Construction of a pulsator

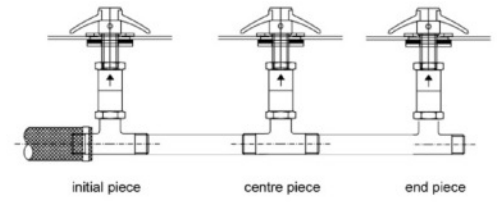
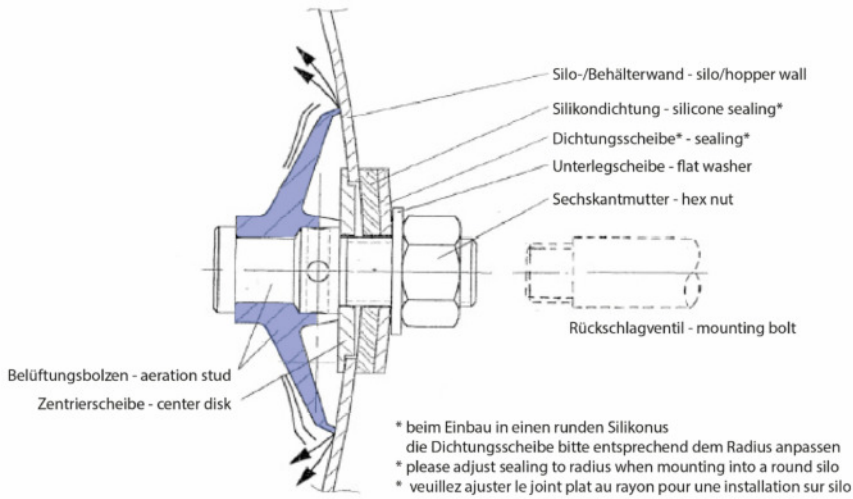

Construction of a pulsator

Service unit with 1 solenoid valve / 3 pulsators

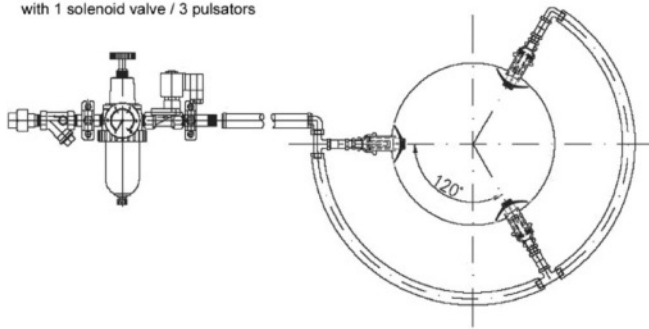

Scale drawing with 3 pulsators

Service unit with 2 solenoid valves / 6 pulsators

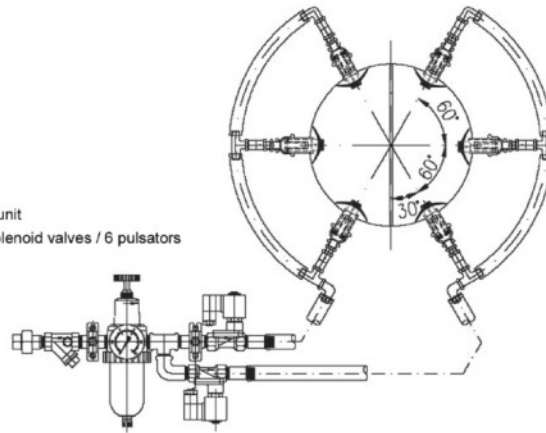

6 pulsators

Service unit with 3 solenoid valves / 9 pulsators

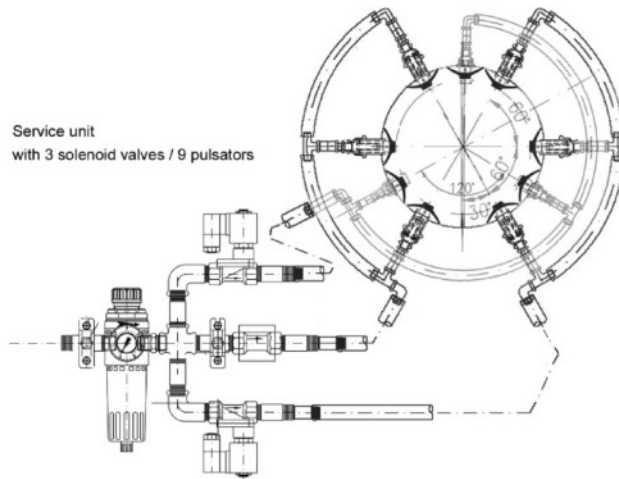

9 pulsators

Technical Data

Number of pulsator	3	6	9
Air consumption at 1,0 bar timed: 3 sec. on / 7 sec. off	225 Nltr. / min.	450 Nltr. / min.	675 Nltr. / min
Operating pressure	1 – 2,0 bar		
Volume flow per injector	250 ltr./ min.		
Max. temperature strain	80° C, higher temperatures on request		
Number of solenoid valves	1	2	3
Connector	G 1/2"		
Pulse duration time	2-3 sec.		
Break duration time	7-10 sec.		
Air (conditions)	Technical dry, oil and foreign substance free		
Voltage on solenoid valve	24VDC (standard) / 230VAC (option)		

Physical data air injector

- Stainless steel 1.4301, AISI 304.
- Operating temperature up to 170° C.

Material

Air and electrical input lead, compressor and fan are not included.

Notice



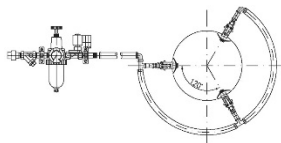
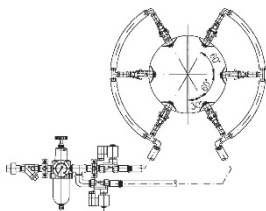
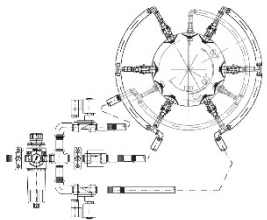

Air injector incl. ring pipe, service unit, solenoid valve

Number of pulsator / solenoid valve	3/1	6/2	9/3
Article number	742 10 049	742 10 063	742 10 051
			









**Please do not forget to specify the control voltage (24VDC or 230VAC)!
Further numbers of injectors on request.**

Clock relay in plastic body IP 54, 230V 50Hz, for on site installation

Clock control STL up to 4 solenoid valves	3/1	6/2	9/3	
	Article number			
230V/DC connection voltage	881 10 229			
24V/DC connection voltage	881 10 229-01			

Equipment / Spare Parts

	Article number	
Pulsator silicone white	742 10 052	
Pulsator mounting set 4 pieces for subsequent installation, in addition a Mounting cable / pull rope required	742 10 055	
Mounting cable/ pull rope	742 10 056	
Hole saw for subsequent installation pulsators	742 10 058	
End piece	ST0713	
T piece	ST2312	
Tube & T-piece	ST0191 ST2312	
Non-return valve	804 10 002	
Air hose transparent per meter	ST2176-PVC	
Solenoid valve 24V/DC	881 10 130	
Solenoid valve 230V/AC	881 10 087	
Solenoid valve ATEX 24V/DC with 3m cable	881 10 087	

Service unit for air injector loosening system complete, 230V/AC, with 1 solenoid valve	742 20 001	
Service unit for air injector loosening system complete, 24V/DC, with 1 solenoid valve	742 20 002	
Service unit for air injector loosening system complete, 24V/DC ATEX 3D , with 1 solenoid valve	742 20 003	
Service unit for air injector loosening system complete, 230V/AC, with 2 solenoid valves	742 20 004	
Service unit for air injector loosening system complete, 24V/DC, with 2 solenoid valves	742 20 005	
Service unit for air injector loosening system complete, 230V/AC, with 3 solenoid valves	742 20 006	
Service unit for air injector loosening system complete, 24V/DC, with 3 solenoid valves	742 20 007	
Service unit for air injector loosening system complete, 24V/DC, with 4 solenoid valves	742 20 008	
Service unit for air injector loosening system complete, 24V/DC ATEX 3D , with 2 solenoid valves	742 20 009	



Additional air fluidisation systems

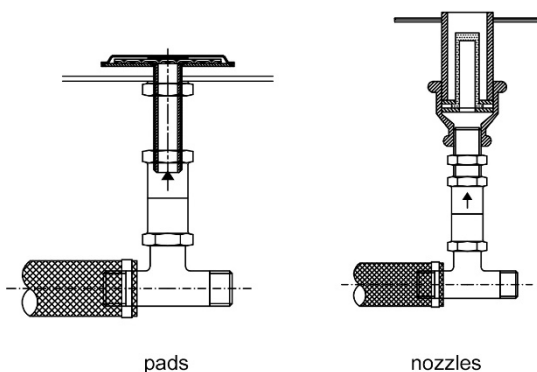

MECHANICAL DISCHARGE DEVICE VIBRATING CAGE



Optional with slider

The Stanelle vibrating cage serves as discharge aid for all lazy flowing and bridge-building, dry, dusty to granulated bulk materials. Major advantage over air operated systems is that the discharged bulk materials do not contain fluidizing air. This has positive effects during bagging as well as when loading silo vehicles. The flanged version with 60° outlet slope can easily be attached to any silo or bunker - even subsequent.

Areas of application

- Free of fluidizing air
- Elimination of disturbing fluidising air
- Simple installation and maintenance
- Non-positive connection - no need for complex constructions to hold the basket
- Compact, wear-protecting design, no protruding parts
- No fragile sleeves
- On request pressure shock resistant up to 3 bar or pressure resistant up to 7 bar, as well as Ex-protected
- Temperature range up to 80° C standard - other temperature ranges on request
- Cone can be heated and insulated

Details / Explanation

Finish

- Rust removal: SA 2,5
- Primer: 2K; 40µm
- Top coat: 2K; RAL 9006; 40µm
- or for stainless steel versions glass bead blasted

Dimensions and technical data

Nominal diameter	Ø 1200	Ø 1500	Ø 1800
D1 ø	1200	1500	1800
D2 ø	1300	1600	1900
Number of holes x ø	32 x ø 18	36 x ø 18	40 x ø 18
D3 – ø, H	on customer inquiry		
Vibration engine	0,16 KW		
Voltage	400, 500, or 690 V		

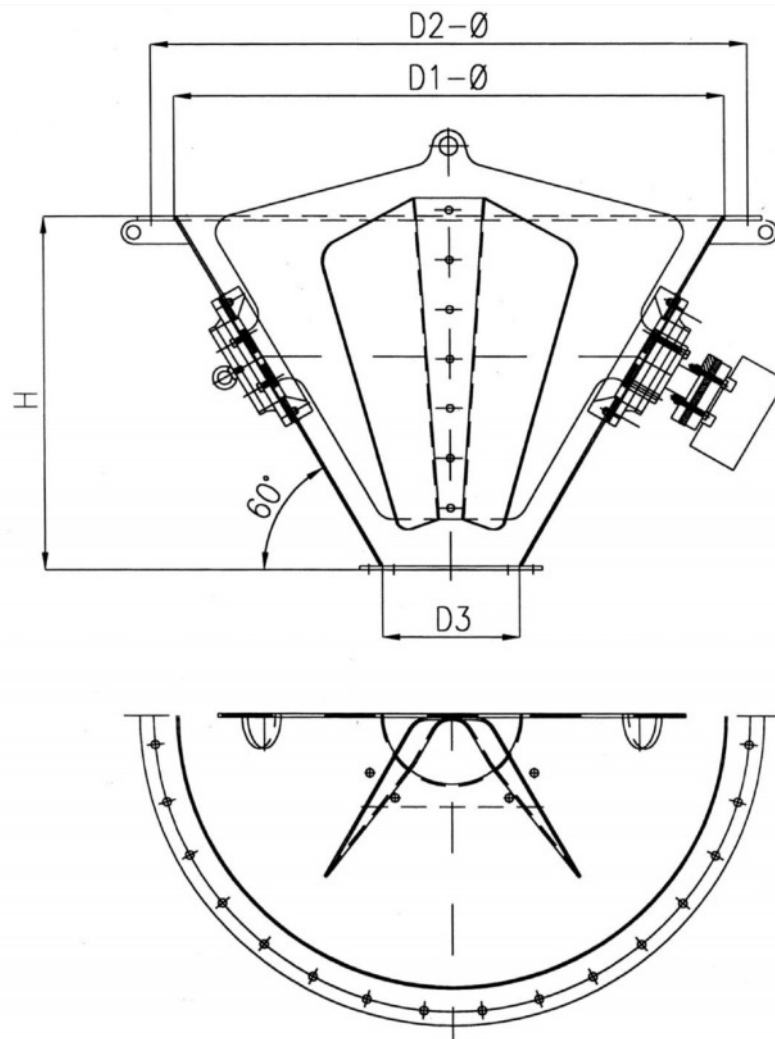

Article number

Nominal diameter 60° / 400V	Ø 1200		Ø 1500		Ø 1800	
	S235JR	VA 1.4301	S235JR	VA 1.4301	S235JR	VA 1.4301
Article number	741 10 006	741 10 008	741 10 005	741 10 009	741 10 004	741 10 010

Nominal diameter 65° / 400V	Ø 1200 S235JR	Ø 1500 S235JR	Ø 1800 S235JR
Article number	741 10 052	741 10 037	741 10 038

Nominal diameter 70° / 400V	Ø 1500	Ø 1800
Article number	741 10 042	741 10 055

Other materials and designs available on request

Notice





Accessories counterflange

Nominal diameter	Ø 1200		Ø 1500		Ø 1800	
	S235JR	VA 1.4301	S235JR	VA 1.4301	S235JR	VA 1.4301
Article number	741 10 006-01	741 10 008-02	741 10 005-01	741 10 009-02	741 10 004-01	741 10 010-02

Equipment / Spare parts

	Article number	
Vibration generator 400 V / AC	882 10 001	
Vibration generator, ATEX , II 2 G/D 	882 10 013	
Discharge star 60° 1200	741 10 046	
Discharge star 60° 1500	741 10 056	
Discharge star 60° 1800	741 10 057	
Clamping plate	741 10 027	
Clamping piece	741 10 026	
Shaft connection	741 10 025	

Equipment / Spare parts

	Article number	
Vibrating element (S235)	741 10 015	
Vibrating element (VA)	741 10 021	

MECHANICAL DISCHARGE DEVICE SVA VIBRATING BOOM



Vibrating boom (installation example)

The Stanelle vibrating boom, Type SVA serves as discharge aid for bridge-building, dry, dusty, to granulated bulk materials. The product can be mounted to rectangular hoppers or special outlets and is individual applicable which is an advantage compared to the discharge vibrating device. The subsequent installation in existing silos or hoppers can be easily accomplished. Through variable vibrating motor installation, the vibrating boom comes in various settings.

Areas of Application

Details / Explanation

- Simple construction
- Simple subsequent installation
- Compact construction, low wear
- Changeable from outside
- Rugged oscillating unit
- Max. operating temperature 80°C
- Various vibration motors available

- Rust removal: SA 2,5
- Primer: 2K; 40µm
- Top coat: 2K; RAL 9006; 40µm
- or for stainless steel versions glass bead blasted

Finish

The vibrating motor is switched on in a pulsating mode. Through this pulsating oscillation, vibration energy is transferred into the bulk material. By changing the centrifugal power as well as the variable pulsating frequency activation, the bulk solid is stimulated. The fine oscillation prevents the bulk material from hardening.

Functionality

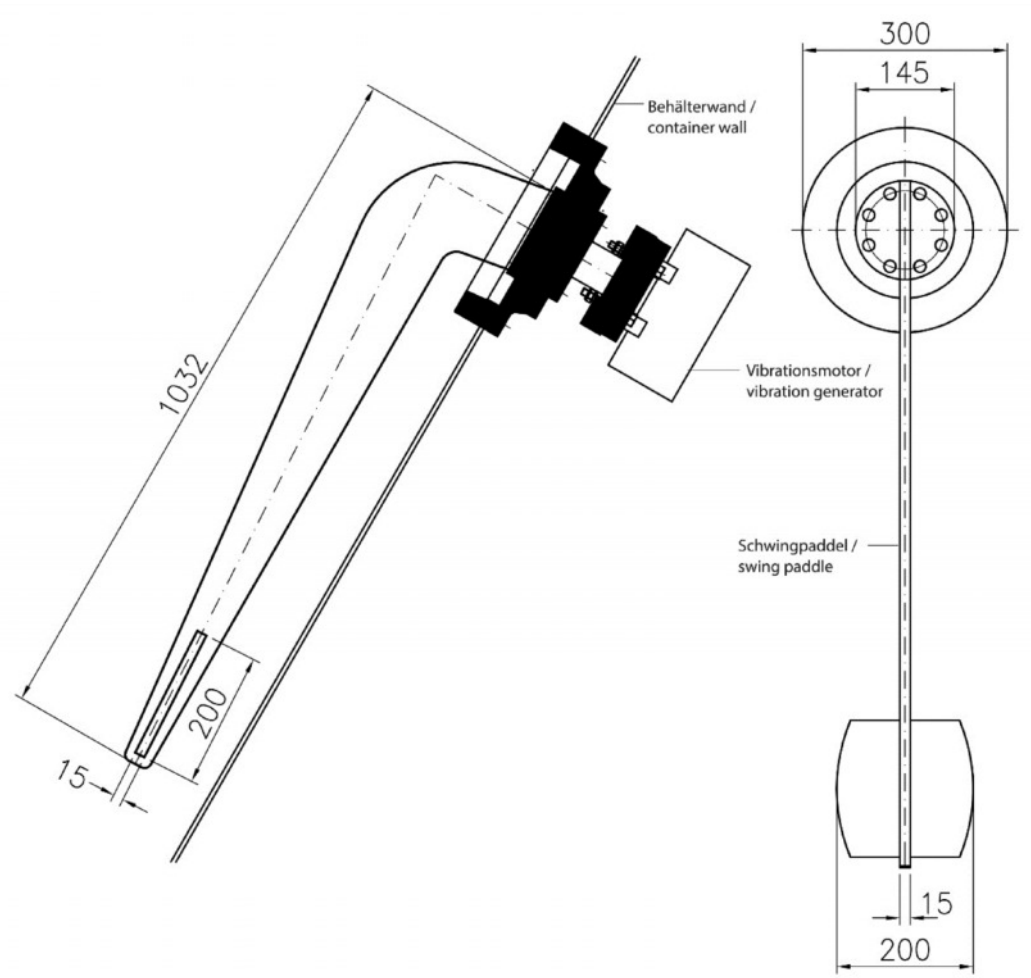

Scale Drawing

Technical data vibrating boom, type SVA

Vibrating Boom	
Arm length approx.	1000 mm
Distance to wall approx.	100 mm
Vibrating motor:	400V/50 Hz, 0,16 kW – 3000Upm
Max. operating temperature:	+80° C

Article number

Material	Steel S235JR	High-grade Steel 1.401
Article number	741 10 007	741 10 019

Equipment / Spare parts

	Article number	
Vibration generator 400 V / AC	882 10 001	
Vibration generator, ATEX , II 2 G/D 	882 10 013	
Clamping plate	741 10 027	
Clamping piece	741 10 026	
Shaft connection	741 10 025	
Vibration paddel as spare part	741 10 059	
Vibrating element (S235)	741 10 015	
Vibrating element (VA)	741 10 021	

MECHANICAL DISCHARGE AID SAD DISCHARGE AND DOSING SYSTEM

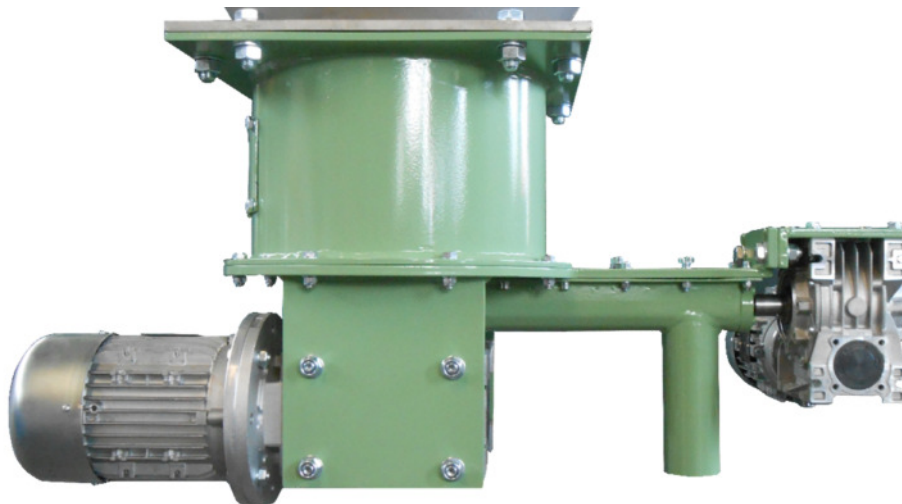

The SAD 300/65 will be used for discharging of very hard flowing bulk products out of silos or bunkers.
The SAD is very suitable for handling of quick lime, activated carbon, gypsum etc.
The installation in existing applications is possible without problems.

Application

- Robust design
- Suitable for special applications
- Easy installation
- Easy maintenance
- Temperature of operation -10° - 80°C

Details / Design

- Designed in stainless steel AISI 304 / AISI 316 glass bead blasted
- Designed in constructional steel S235JR
Sandblasting SA 2 ½ .
painting: RAL 9006 white aluminium

Finish

The vertical agitator is driven by a gear motor separately. It breaks up the product and loosens the product in the outlet area. A steady and smooth discharge will be ensured out of a silo or bunker .

Function

The horizontal discharge and dosing screw is designed with a progressive pitch. It allows a controlled discharge with constant volume flows

The screw is driven by a gear motor which is designed for operation at a frequency converter. A variable operation is possible to realise volume flows 15 up to 75 Liter/h.

Dimension sheet

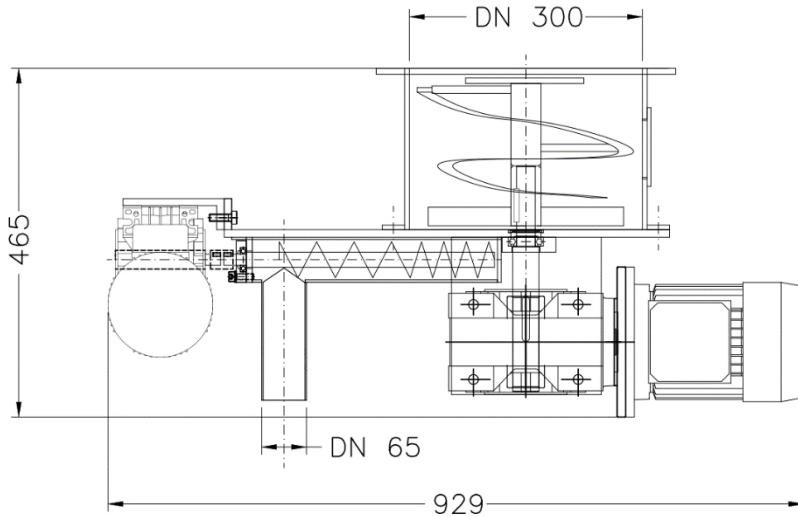

Process of discharge



Technical Data SAD 300/65

SAD 300/65	
DN300 – (other sizes on request)	
Discharge and dosing capacity	15 bis 75 Liter/ h
Electr. Power Dosage	0,25 kW; 230/400V; IP55; suitable for use at frequency converter
Electr. Power agitator	0,55 kW; 230/400V; IP55,

Article Number

Design	Structural steel	Stainless steel
Article number	782 10 017	782 10 018

Other sizes and applications according to your requirements on request.

Please provide the characteristics of the media to be extracted when you make an inquiry: e.g. Cement, lime, feed, salt, sugar, etc.

Notice



**COMPACT AND ROBUST COMPONENTS FOR
A WIDE RANGE OF APPLICATIONS
BUTTERFLY VALVE WITH ONE FLANGE**



Everywhere where flexible connections are required. A rubber or a cloth collar connects to the downstream element. Typical example: Between silo and scale, sieving machine etc.

Areas of Application

- Three operating types:
 - H = Hand driven
 - EP = Electro-pneumatic actuation
 - GM = Motor actuation
- Every time there is a change in the operating procedure, it is possible to change the butterfly valves to another operating type.

Details / Explanation

- Flap body: Aluminum (Chill casting)
- Flap plate: Material grade GG with neoprene-rubber coating
- Journal Extension: Material grade C40, with self-lubricating plastic bushes which do not encounter with the material.

Finish

Basic Unit / Operating types:

Basic unit F1

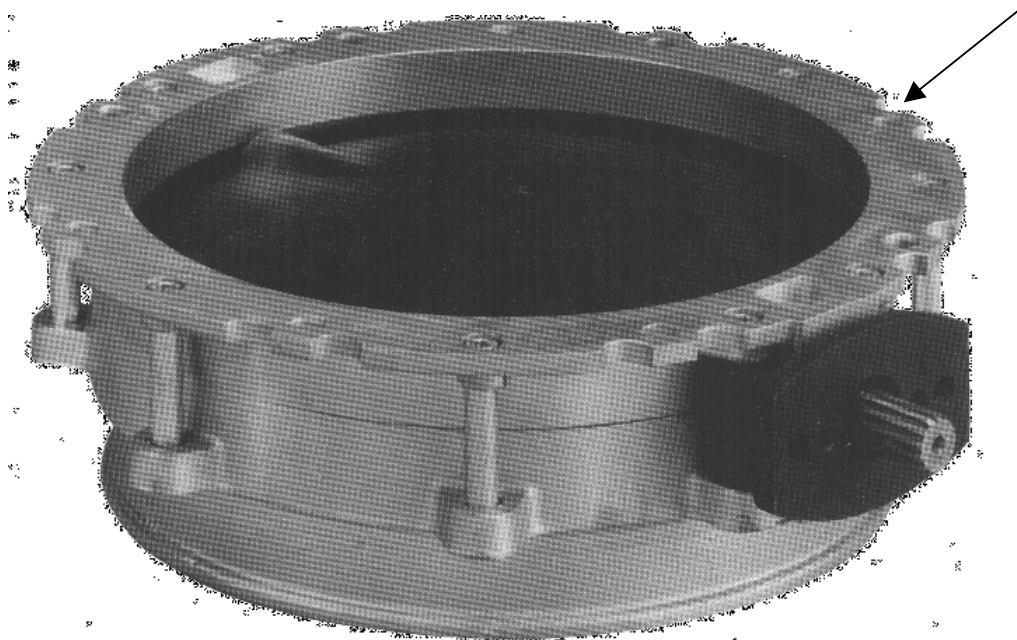

H = Hand driven

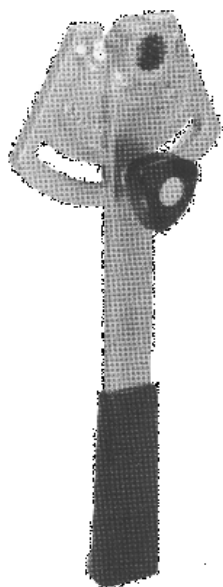

EP = Electro-pneumatic actuation

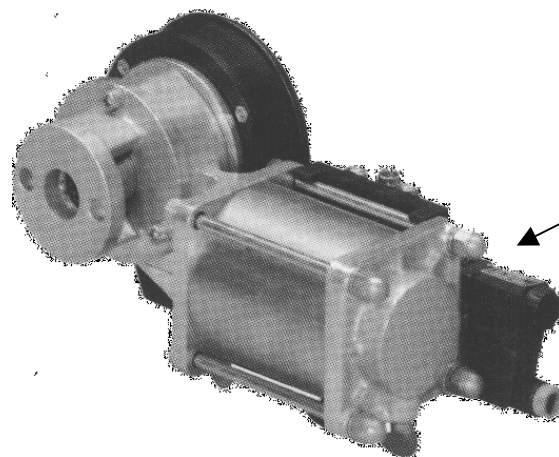

GM = Drive motor actuation

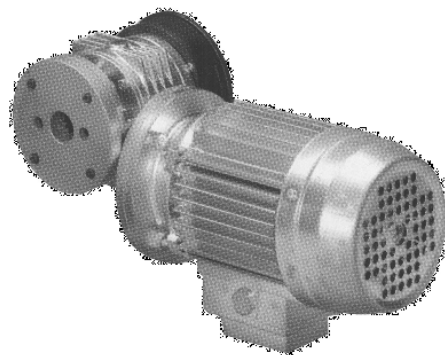

Technical Data Butterfly valve F1

Operating type	Hand driven (H)	Electro-pneumatic (EP)	Drive motor (GM)
Flange diameter ø mm	150, 200, 250, 300	150, 200, 250, 300	150, 200, 250, 300
Actuation	H2	EP80, EP100	GM2, GM3
Solenoid valve	--	MV5/2-8 = 3/8" thread plug	--
Coil	--	230V AC	--
Limit switch	--	Micro switch, end switch open / close	--

Article number Butterfly valve F1

Operating type	Hand driven (H)	Electro-pneumatic (EP)	Drive motor (GM)
	Article number	Article number	Article number
Flange diameter ø 150 mm	711 10 024	711 10 044	711 10 033
Flange diameter ø 200 mm	711 10 025	711 10 045	711 10 034
Flange diameter ø 250 mm	711 10 026	711 10 046	711 10 035
Flange diameter ø 300 mm	711 10 006	711 10 047	711 10 036
Flange diameter ø 350 mm	711 10 049	711 10 051	711 10 071
MGV 24V DC Additional charge	--	--	
Limit switch	--	711 10 060	711 10 060

**COMPACT AND ROBUST COMPONENTS FOR
A WIDE RANGE OF APPLICATIONS
BUTTERFLY VALVE WITH ONE FLANGE**



Everywhere where flexible connections are required. A rubber or a cloth collar connects to the downstream element. Typical example: Between silo and scale, sieving machine etc.

Areas of Application

- Three operating types:
 - H = Hand driven
 - EP = Electro-pneumatic actuation
 - GM = Motor actuation
- Every time there is a change in the operating procedure, it is possible to change the butterfly valves to another operating type.

Details / Explanation

- Flap body: Aluminum (Chill casting)
- Flap plate: Material grade GG with neoprene-rubber coating
- Journal Extension: Material grade C40, with self-lubricating plastic bushes which do not encounter with the material.

Finish

Basic Unit / Operating types:

Basic unit F2

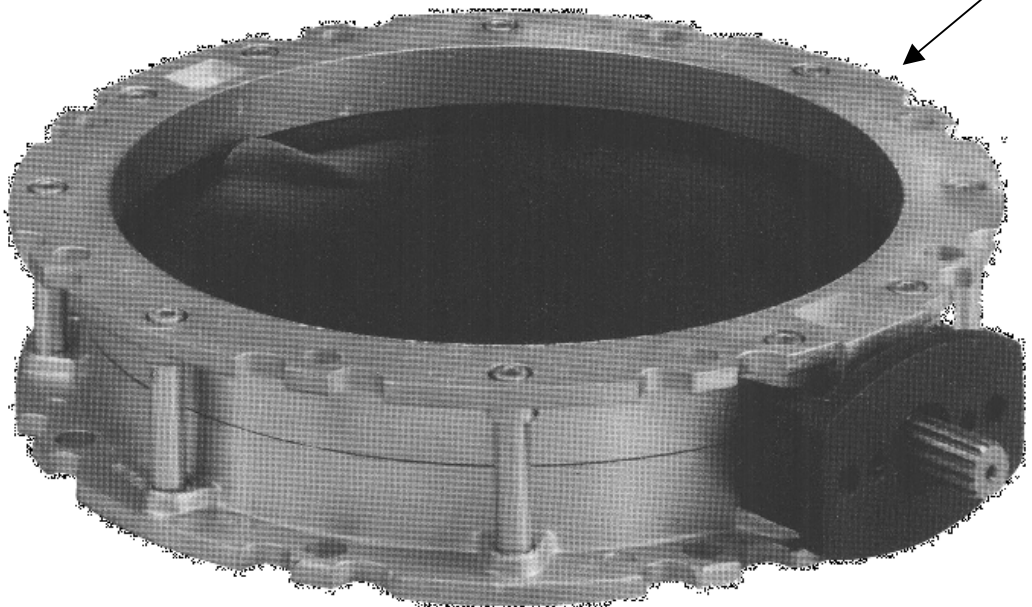

H = Hand driven

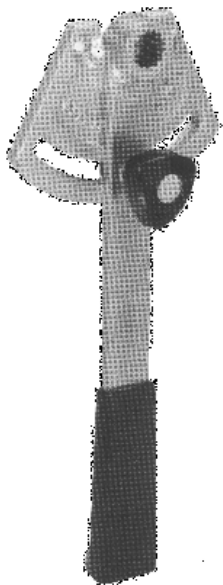

**EP = Electro-pneumatic
actuation**

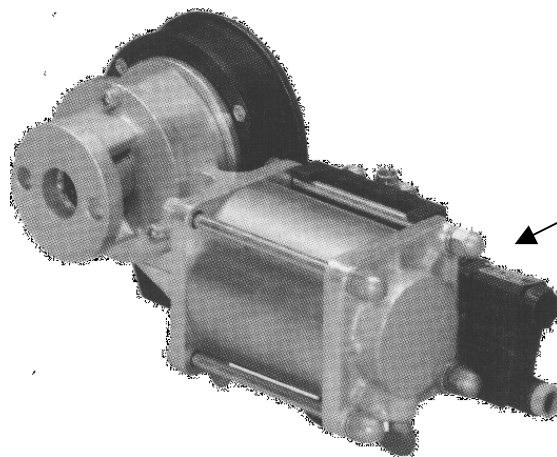

**GM = Drive motor
actuation**

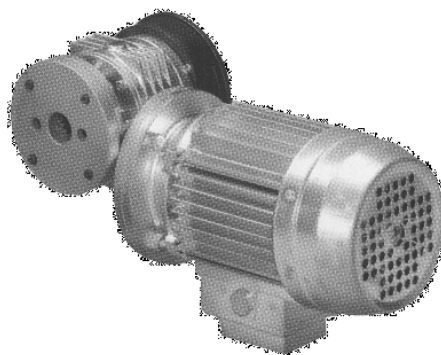

Technical Data Butterfly valve F2

Operating type	Hand driven (H)	Electro-pneumatic (EP)	Drive motor (GM)
Flange diameter ø mm	150, 200, 250, 300	100, 150, 200, 250, 300, 350, 400	100, 150, 200, 250, 300, 350, 400
Actuation	H2, H3	EP80, EP100, EP125	GM2, GM3
Solenoid valve	--	MV5/2-4 = ¼ " thread plug	--
Coil	--	230V AC	--
Limit switch	--	Micro switch, end switch open / close	--

Article number Butterfly valve F2

Operating type	Hand driven (H)	Electro-pneumatic (EP)	Drive motor (GM)
	Article number	Article number	Article number
Flange diameter ø 100 mm	711 10 027	711 10 014	711 10 048
Flange diameter ø 150 mm	711 10 028	711 10 012	711 10 037
Flange diameter ø 200 mm	711 10 029	711 10 015	711 10 038
Flange diameter ø 250 mm	711 10 030	711 10 016	711 10 039
Flange diameter ø 300 mm	711 10 001	711 10 017	711 10 040
Flange diameter ø 350 mm	711 10 031	711 10 018	711 10 041
Flange diameter ø 400 mm	711 10 032	711 10 019	711 10 042
MGV 24V DC Additional charge	--	--	--
Limit switch	--	711 10 060	711 10 060

MODULAR FLAT GATE VALVE TYPE SMFS-HD

SHUT-OFF - COMPONENT FOR SILO AND CONTAINER SYSTEMS WITH OPTIMAL SEALING – HAND DRIVEN



The **modular gate valve TYPE SMFS-HD** is attached to silo and vessel discharges and assures the optimal sealing of stored dusty and granular bulk goods up to 8 mm in size. This modular gate allows the installation of various drive configurations - manual, pneumatic, or electric motor driven - on the same base frame.

Areas of Application

- Grain size up to 8 mm
- High quality gate plate sealing; packing box easily adjustable and exchangeable
- Slide plate made of stainless steel 1.4301, ground
- Steel guide on the slide gates upper side
- Ball track rollers sealed on both sides
- Large, easily removable protective covers
- Low overall height
- Ex-protected
- Special paintwork on request
- Special sizes on request
- High-temperature version
- position indicator
- Other materials: e.g. stainless steel 1.4301 / 1.4571

Details / Explanation

- Rust removal: SA 2,5
- Primer: 2K; 40µm
- Top coat: 2K; RAL 9006; 40µm

Finish

Spare parts drawing

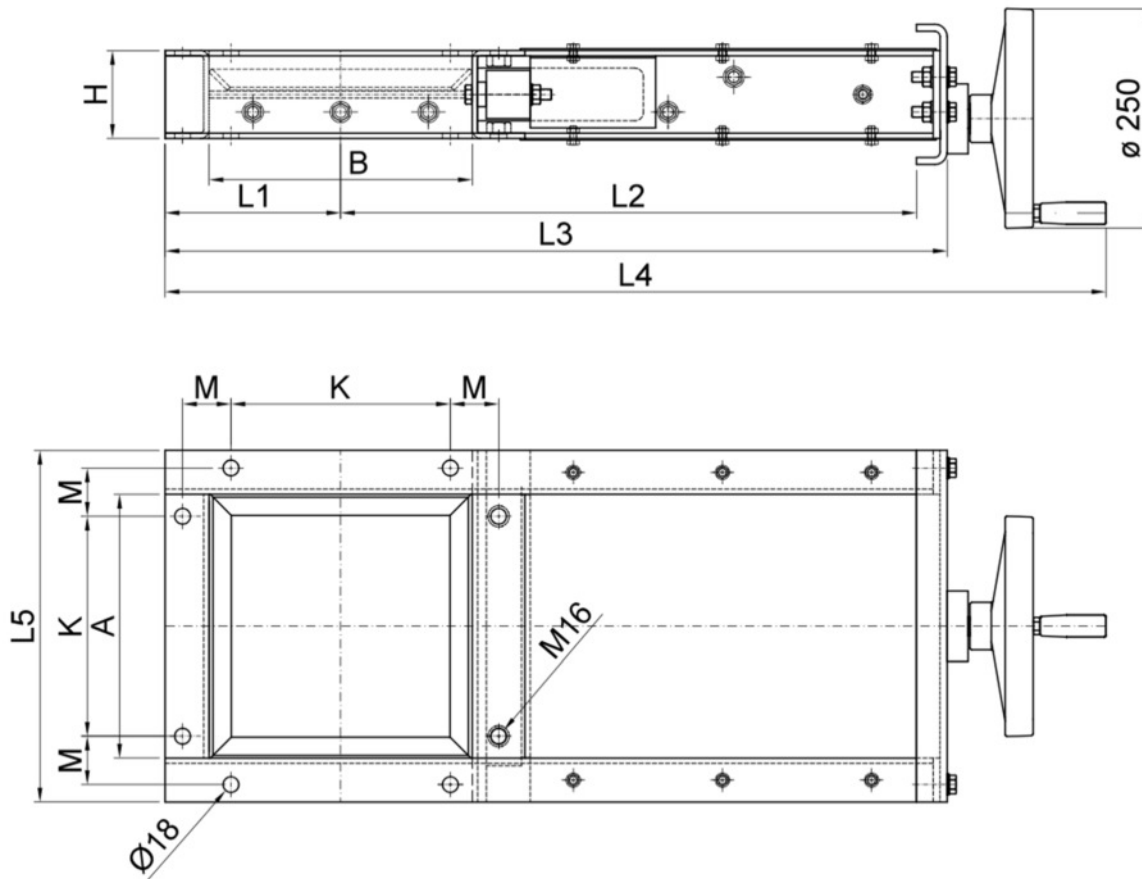

Dimensions Flat Gate Type SMFS - HD

AxB [mm]	Article No.	Weight [kg]	K [mm]	M [mm]	L1 [mm]	L2 [mm]	L3 [mm]	L4 [mm]	L5 [mm]	H [mm]
200x200	712 10 278	40	150	55	150	507	690	870	300	100
250x250	712 10 294	43	200	55	175	575	790	970	350	100
300x300	712 10 269	46	250	55	200	650	890	1070	400	100
350x350	712 10 301	55	280	65	225	726	990	1170	450	100
400x400	712 10 272	59	300	80	250	800	1090	1270	500	100
450x450	712 10 296	62	330	90	275	881	1190	1370	550	100
500x500	712 10 275	65	350	105	300	950	1290	1470	600	100
600x600	712 10 305	87	380	120	325	1025	1390	1570	700	120

Subject to technical changes

Special solutions gate valve type SMFS - HD
Special sizes on request

Notice





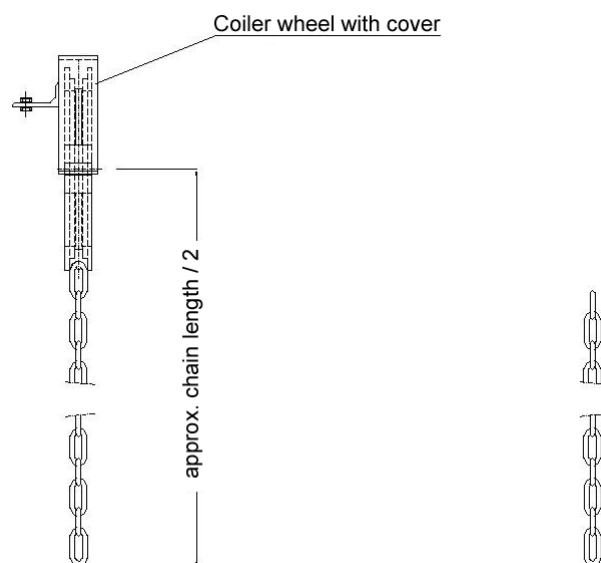

OPTION: Actuation / reel wheel





Specify chain length when ordering

D1 [mm]	Reel wheel Art No.	Weight [kg]	Chain according to DIN 766 Art No.	Weight / m [kg]
260	712 10 135	5	712 10 136	0,75

Accessories / Spare parts

	Article No.	
Handwheel	712 10 132	
Ball bearing - standard	712 10 143	
Bearing bush for manual slide valve	712 10 268 109	
Spacer sleeve	60-108	
Trapezoidal screw nut	712 10 269 108	

	Type	Article No.	
Trapezoidal threaded spindle	SMFS 200 x 200	712 10 278 107	
	SMFS 250 x 250	712 10 294 107	
	SMFS 300 x 300	712 10 269 107	
	SMFS 350 x 350	712 10 301 107	
	SMFS 400 x 400	712 10 272 107	
	SMFS 450 x 450	712 10 296 107	
	SMFS 500 x 500	712 10 275 107	

	Type	Article No.	
Stuffing box packing / Gasket Set for 1 slider (3 pieces)	SMFS 200 x 200	712 10 285	
	SMFS 250 x 250	712 10 286	
	SMFS 300 x 300	712 10 287	
	SMFS 350 x 350	712 10 288	
	SMFS 400 x 400	712 10 289	
	SMFS 450 x 450	712 10 290	
	SMFS 500 x 500	712 10 291	

	Type	Article No.	
Gasket block	SMFS 200 x 200	712 10 278 102	
	SMFS 250 x 250	712 10 294 102	
	SMFS 300 x 300	712 10 268 102	
	SMFS 350 x 350	712 10 282 102	
	SMFS 400 x 400	712 10 274 102	
	SMFS 450 x 450	712 10 296 102	
	SMFS 500 x 500	712 10 275 102	

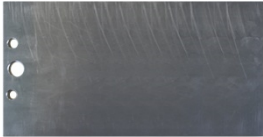
	Type	Article No.	
Slide plate	SMFS 200 x 200	712 10 278 101	
	SMFS 250 x 250	712 10 294 101	
	SMFS 300 x 300	712 10 268 101	
	SMFS 350 x 350	712 10 282 101	
	SMFS 400 x 400	712 10 274 101	
	SMFS 450 x 450	712 10 296 101	
	SMFS 500 x 500	712 10 275 101	

MODULAR FLAT GATE VALVE TYPE SMFS-HD

SHUT-OFF - COMPONENT FOR SILO AND CONTAINER SYSTEMS WITH OPTIMAL SEALING – ELECTRO PNEUMATIC



The **modular gate valve TYPE SMFS-EP** is attached to silo and vessel discharges and assures the optimal sealing of stored dusty and granular bulk goods up to 8 mm in size. The pneumatically activated flat gate is normally used as a proportional slide gate. This modular gate allows the installation of various drive configurations - manual, pneumatic, or electric motor driven - on the same base frame.

Areas of Application

- Grain size up to 8 mm
- High quality gate plate sealing; packing box easily adjustable and exchangeable
- Slide plate made of stainless steel 1.4301, ground
- Steel guide on the slide gates upper side
- Ball track rollers sealed on both sides
- Large, easily removable protective covers
- Low overall height
- Ex-protected
- Special paintwork on request
- Special sizes on request
- High-temperature version
- position indicator
- Other materials: e.g. stainless steel 1.4301 / 1.4571

Details / Explanation

- Rust removal: SA 2,5
- Primer: 2K; 40µm
- Top coat: 2K; RAL 9006; 40µm

Finish

Spare parts drawing

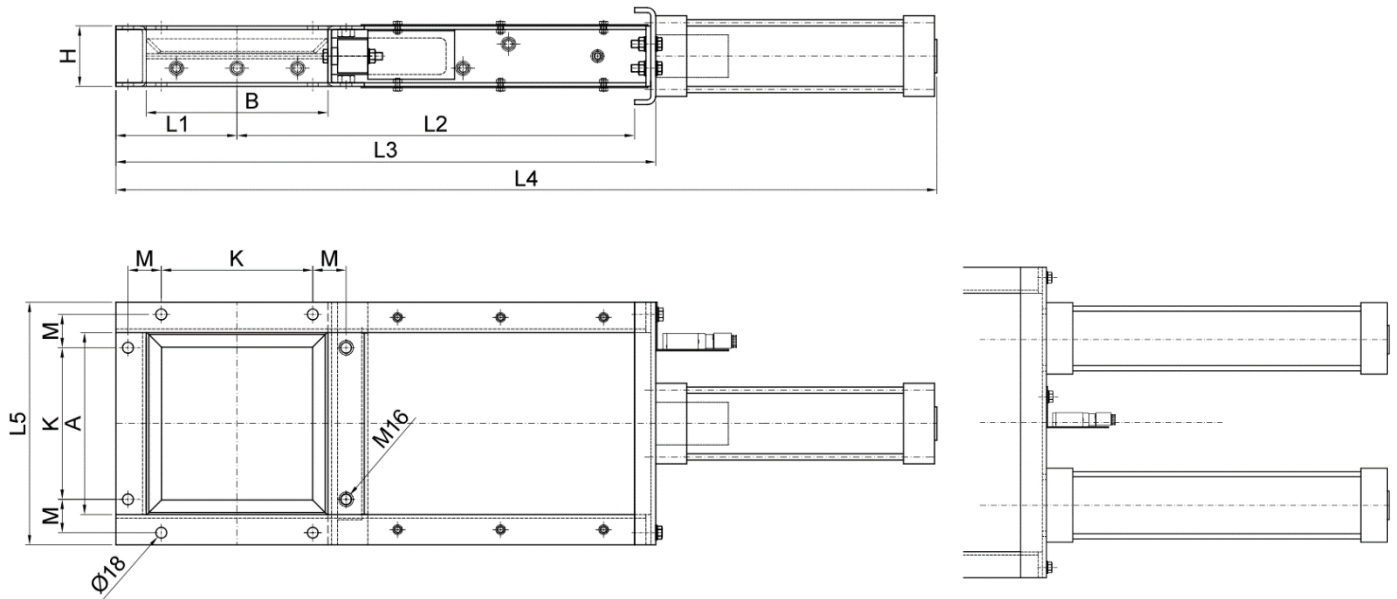

Dimensions Flat Gate Type SMFS - EP

AxB [mm]	Article No.	Weight [kg]	K [mm]	M [mm]	L1 [mm]	L2 [mm]	L3 [mm]	L4 [mm]	L5 [mm]	H [mm]	DxHub [mm]	d
200x200	712 10 279	48	150	55	150	500	690	1155	300	100	Ø100x200	1/4"
250x250	712 10 284	52	200	55	175	575	790	1255	350	100	Ø100x250	1/4"
300x300	712 10 268	55	250	55	200	650	890	1355	400	100	Ø100x300	3/8"
350x350	712 10 282	61	280	65	225	726	990	1545	450	100	Ø125x350	3/8"
400x400	712 10 273	65	300	80	250	800	1090	1645	500	100	Ø125x400	1/2"
450x450	712 10 302	84	330	90	275	881	1190	1855	550	100	Ø125x450	1/2"
500x500	712 10 276	95	350	105	300	950	1290	1955	600	100	2xØ125x50	1/2"
600x600	712 10 306	118	380	120	325	1025	1390	2055	700	120	2xØ125x60	1/2"



Subject to technical changes

Special solutions gate valve type SMFS - EP
Special sizes on request

Notice



Accessories / Spare parts

	Article No.	
Pneumatic cylinder	881 10 105	
Fork head	ST1779	
Reed switch for cylinders 24V DC / 230V AC	881 10 214	
Limit switches 24V/DC IG5533	881 10 270	
Limit switches 230V/AC IG0006	881 10 222	
Solenoid valve 5/2 24V/DC Standard	881 10 165	
Solenoid valve 5/2 230V/AC Standard	881 10 164	
Solenoid valve 5/3 24V/DC for intermediate position	881 10 177-01	
Solenoid valve 5/3 230V/AC for intermediate position	881 10 177-02	
Ball bearing - standard	712 10 143	

	Type	Article No.	
Stuffing box packing / Gasket Set for 1 slider (3 pieces)	SMFS 200 x 200	712 10 285	
	SMFS 250 x 250	712 10 286	
	SMFS 300 x 300	712 10 287	
	SMFS 350 x 350	712 10 288	
	SMFS 400 x 400	712 10 289	
	SMFS 450 x 450	712 10 290	
	SMFS 500 x 500	712 10 291	

	Type	Article No.	
Gasket block	SMFS 200 x 200	712 10 278 102	
	SMFS 250 x 250	712 10 294 102	
	SMFS 300 x 300	712 10 268 102	
	SMFS 350 x 350	712 10 282 102	
	SMFS 400 x 400	712 10 274 102	
	SMFS 450 x 450	712 10 296 102	
	SMFS 500 x 500	712 10 275 102	

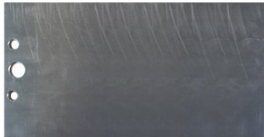
	Type	Article No.	
Slide plate	SMFS 200 x 200	712 10 278 101	
	SMFS 250 x 250	712 10 294 101	
	SMFS 300 x 300	712 10 268 101	
	SMFS 350 x 350	712 10 282 101	
	SMFS 400 x 400	712 10 274 101	
	SMFS 450 x 450	712 10 296 101	
	SMFS 500 x 500	712 10 275 101	

Spare parts old version

	Type	Article No.	
Seal kit 2 x round felt + X x half round felt	flat slide 200 x 200	712 10 142	
	flat slide 250 x 250	712 10 064	
	flat slide 300 x 300	712 10 003	
	Flachschieber 400 x 400	712 10 058	
	flat slide 500 x 500	712 10 189	

Pressing device	712 10 251	
-----------------	------------	---

MODULAR FLAT GATE VALVE TYPE SMFS-GM

SHUT-OFF - COMPONENT FOR SILO AND CONTAINER SYSTEMS WITH OPTIMAL SEALING – MOTOR DRIVEN



The **modular gate valve TYPE SMFS-GM** is attached to silo and vessel discharges and assures the optimal sealing of stored dusty and granular bulk goods up to 8 mm in size. The motor driven flat gate can also be used as a proportional slide gate. This modular gate allows the installation of various drive configurations - manual, pneumatic, or electric motor driven - on the same base frame.

Areas of Application

- Grain size up to 8 mm
- High quality gate plate sealing; packing box easily adjustable and exchangeable
- Slide plate made of stainless steel 1.4301, ground
- Steel guide on the slide gates upper side
- Ball track rollers sealed on both sides
- Large, easily removable protective covers
- Low overall height
- Ex-protected
- Special paintwork on request
- Special sizes on request
- High-temperature version
- position indicator
- Other materials: e.g. stainless steel 1.4301 / 1.4571

Details / Explanation

- Rust removal: SA 2,5
- Primer: 2K; 40µm
- Top coat: 2K; RAL 9006; 40µm

Finish

Spare parts drawing

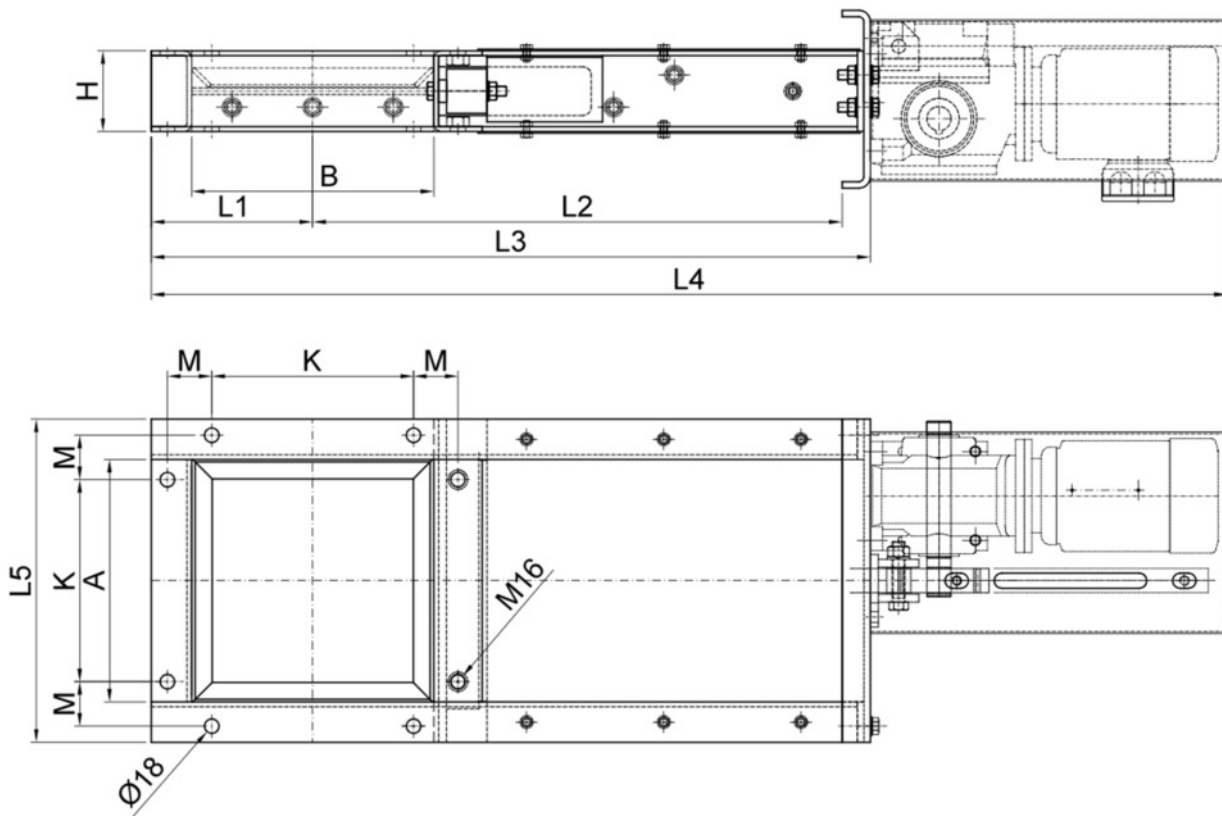

Dimensions Flat Gate Type SMFS - GM

AxB [mm]	Article No.	Weight [kg]	K [mm]	M [mm]	L1 [mm]	L2 [mm]	L3 [mm]	L4 [mm]	L5 [mm]	H [mm]	Proximity switches	P [kW]
200x200	712 10 280	62	150	55	150	500	690	1140	300	100	24V DC/ 230V AC or mechanical	0,83 230/400V (3,4/2,0A) 50 Hz
250x250	712 10 299	67	200	55	175	575	790	1240	350	100		
300x300	712 10 270	75	250	55	200	650	890	1340	400	100		
350x350	712 10 300	78	280	65	225	726	990	1440	450	100		
400x400	712 10 274	80	300	80	250	800	1090	1635	500	100		
450x450	712 10 303	92	330	90	275	881	1190	1685	550	100		
500x500	712 10 277	105	350	105	300	950	1290	1933	600	100		
600x600	712 10 307	133	380	120	325	1025	1390	2030	700	120		

Subject to technical changes

Special solutions gate valve type SMFS - GM
Special sizes on request

Notice



Accessories / Spare parts

	Article No.	
Geared motor 0,83 kW/400V/AC	712 10 256	
Geared motor 1,1 kW/400V/AC	712 10 256-01	
Limit switches 24V/DC IG5533	881 10 270	
Limit switches 230V/AC IG0006	881 10 222	
Limit switch mechanical	751 10 080	
Ball bearing - standard	712 10 143	

	Type	Article No.	
Stuffing box packing / Gasket Set for 1 slider (3 pieces)	SMFS 200 x 200	712 10 285	
	SMFS 250 x 250	712 10 286	
	SMFS 300 x 300	712 10 287	
	SMFS 350 x 350	712 10 288	
	SMFS 400 x 400	712 10 289	
	SMFS 450 x 450	712 10 290	
	SMFS 500 x 500	712 10 291	

	Type	Article No.	
Gasket block	SMFS 200 x 200	712 10 278 102	
	SMFS 250 x 250	712 10 294 102	
	SMFS 300 x 300	712 10 268 102	
	SMFS 350 x 350	712 10 282 102	
	SMFS 400 x 400	712 10 274 102	
	SMFS 450 x 450	712 10 296 102	
	SMFS 500 x 500	712 10 275 102	

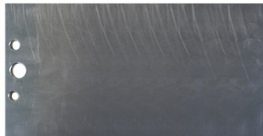
	Type	Article No.	
Slide plate	SMFS 200 x 200	712 10 278 101	
	SMFS 250 x 250	712 10 294 101	
	SMFS 300 x 300	712 10 268 101	
	SMFS 350 x 350	712 10 282 101	
	SMFS 400 x 400	712 10 274 101	
	SMFS 450 x 450	712 10 296 101	
	SMFS 500 x 500	712 10 275 101	

Spare parts old version

	Type	Article No.	
Seal kit 2 x round felt + X x half round felt	flat slide 200 x 200	712 10 142	
	flat slide 250 x 250	712 10 064	
	flat slide 300 x 300	712 10 003	
	flat slide 400 x 400	712 10 058	
	flat slide 500 x 500	712 10 189	

Pressing device	712 10 251	
-----------------	------------	---

MODULAR FLAT GATE TYPE SMFS – GK GM
COARSE GRAIN GATE

CLOSING GATE FOR SILO- AND BUFFER OUTLET WITH SPECIAL SEALING
FOR FREE FLOWING BULK PRODUCTS –
OPERATED BY ELECTRIC MOTOR



The **Flat slide gate TYPE SMFS GK Series** will be mounted at the outlet of a silo or buffers to interrupt the free flow of bulk products. It ensures the best tightness of storing of grainy bulk products with a grain size up to 50 mm.

Application

By the modular design, the slide gate can be equipped with different operation tools. Possible operation: manual operated by hand wheel, pneumatic operated, electro motor operated. Because of the grain size, electro motor operation will be recommended.

- For bulk products with grain size up to 50 mm
- High quality, robust slide plate sealing; stuffing box changeable from outside and easy maintenance
- Product guiding plate on top of inlet
- Roller ball sealing
- Big covering for easy maintenance
- Changeable closing bar, material Polyurethane
- Low installation height (160 mm)
- operation temperature - standard – -10° C till + 100° C
– other temperature on request
- proximity switch for open / close, intermediate position
- emergency closing / opening possible
- Special design on request

Design / Features

- Housing made of steel (standard) or stainless steel
- Slide plate 8 mm, stainless steel AISI 304, grinded
- Surface treatment: 2K-PUR-AC RAL 9006 white aluminum ; 40µm
- Other finish on request

Material

Dimensions

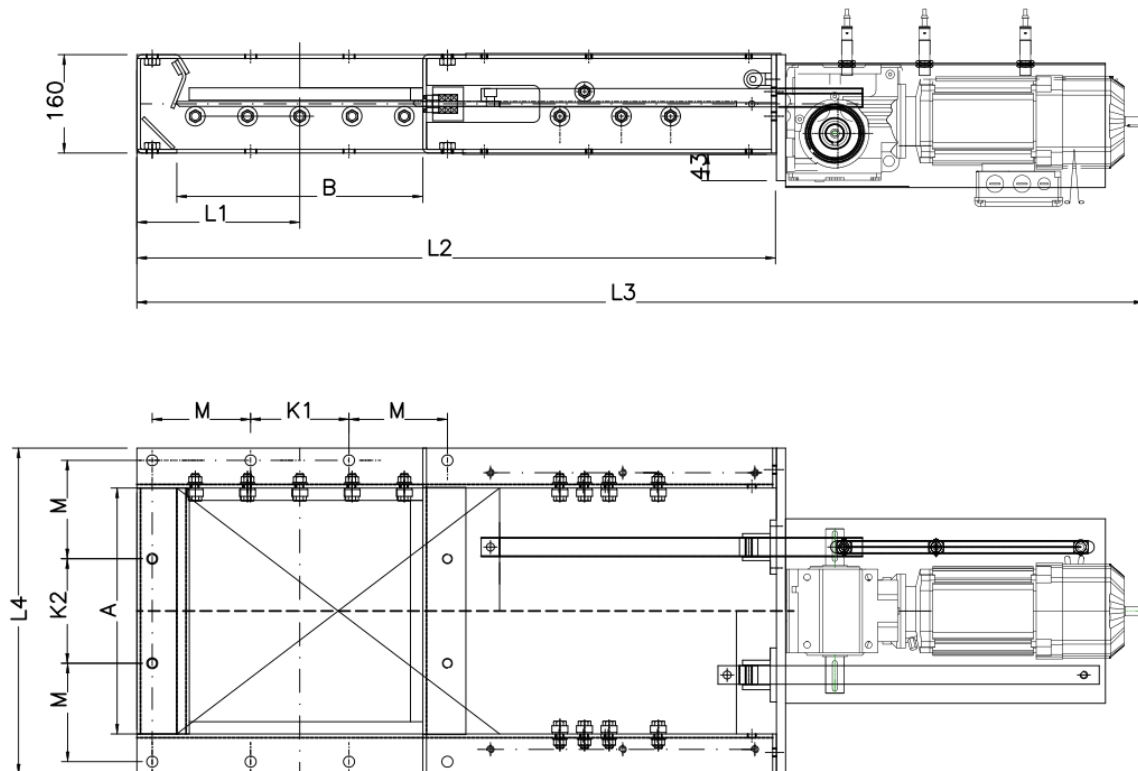

Slide gate Type SMFS – GK GM

NW	300 x 300	400 x 400	500 x 500	600 x 600
A x B	300 x 300	400 x 400	500 x 500	600 x 600
L1	215	265	315	465
L2	840	1040	1240	1440
L3	1440	1640	1840	2040
L4	430	530	630	730
K1/K2	130/130	160/170	210/220	360/370
M	130	160	185	210

Technical Data Slide gate Type SMFS – GK GM

NW	300 x 300	400 x 400	500 x 500	600 x 600
Weight	120 kg	160 kg	190 kg	220 kg
Gear motor	0,75 kW; 230/400 V (3,4/2,0 A)		1,1 kW; 230/400 V	
Proximity	Proximity switch IFM IG5593			
Operation	Module 3 , 2 pcs rack			

Article No

NW	300 x 300	400 x 400	500 x 500	600 x 600
Art No	712 10 910	712 10 911	721 10 912	712 10 913

SHUT-OFF DEVICE USED AS IN-BETWEEN FLANGE ARMATURE

WITH HAND WHEEL



OR

PNEUMATIC CYLINDER



- Available with pneumatic cylinder or hand wheel
- The gate valve can be pressurized unidirectional
- On the valve body the word “seatside” is ingrained which shows the position of the seat which has to be flanged on
- You have to care for an exact fit of the counter flange when installing the unit. A wrong installation position can lead to abrasion and malfunction of the gate valve.
- The pneumatic gate valve is usually equipped with a double-acting cylinder. Single-acting cylinders (e.g. spring loaded opening/closing) can also be used. Actuating pressure of 5 to 6 bar is required. Please ensure to use clean air (water separator, oil vaporizer, etc.)

Areas of Application

Details / Explanation

Hand wheel

- Gate body: Gray cast iron
- Gate plate: Stainless Steel 1.4301
- Sealing: Body: Metal
Soft packing: cotton cord

Pneumatic Cylinder

- Gate body: Gray cast iron, coated RAL 5015 (blue)
- Gate plate: Stainless Steel 1.4301, protected
- Sealing: Body: Metal
Soft packing: PTFE impregnated

Finish

Parts list gate:

- 1 Body
- 2 Soft packing latch
- 3 Gate plate
- 5 Soft packing kit (V)
- 6 Seal ring (Soft packing kit) (V)
- 7 Holding ring (V)
- 8 Body sealing (V)

The units marked with (V) are exposed to high abrasion and need to be replaced as necessary to avoid malfunction.

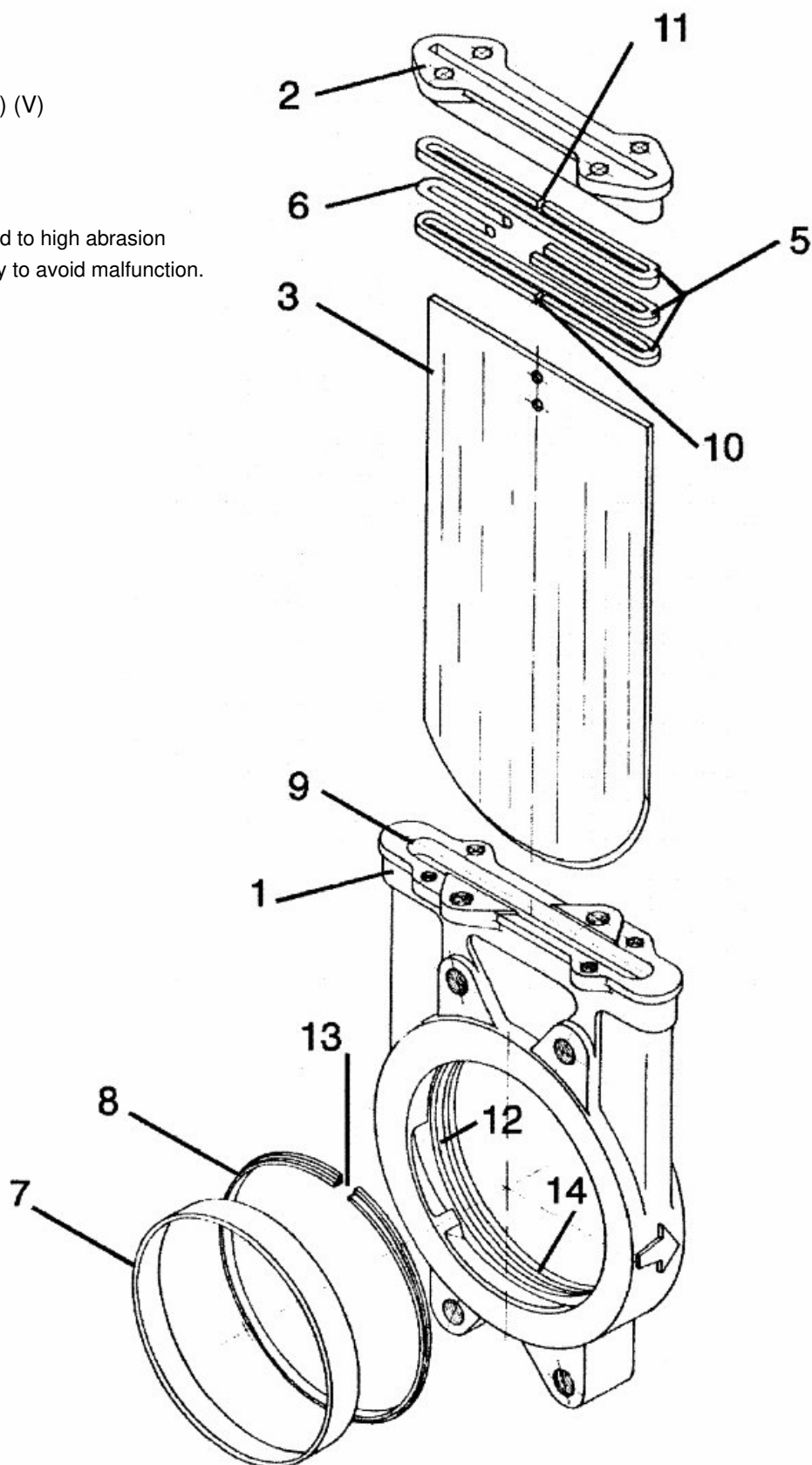

Dimensions Round Gate Valve Type Hand wheel

DN	A	B	C	D	E	F	ØG1	H1	X
50	40	124	90	105	46	46	200	426	9
65	40	139	90	115	46	46	200	453	9
80	50	154	90	124	46	46	200	478	9
100	50	174	90	140	46	46	200	519	9
125	50	192	104	150	51	51	250	603	9
150	60	217	104	175	51	51	250	654	9
200	60	270	118	205	68	68	310	825	9
250	70	326	118	250	68	68	310	1028	9
300	70	380	118	300	68	68	310	1127	12
350	96	438	193	338	97	67	410	1332	12
400	100	493	193	392	97	67	410	1436	12
450	106	546	197	432	97	67	550	1600	12
500	110	620	197	485	97	67	550	1713	12
600	110	714	197	590	97	67	550	2028	12

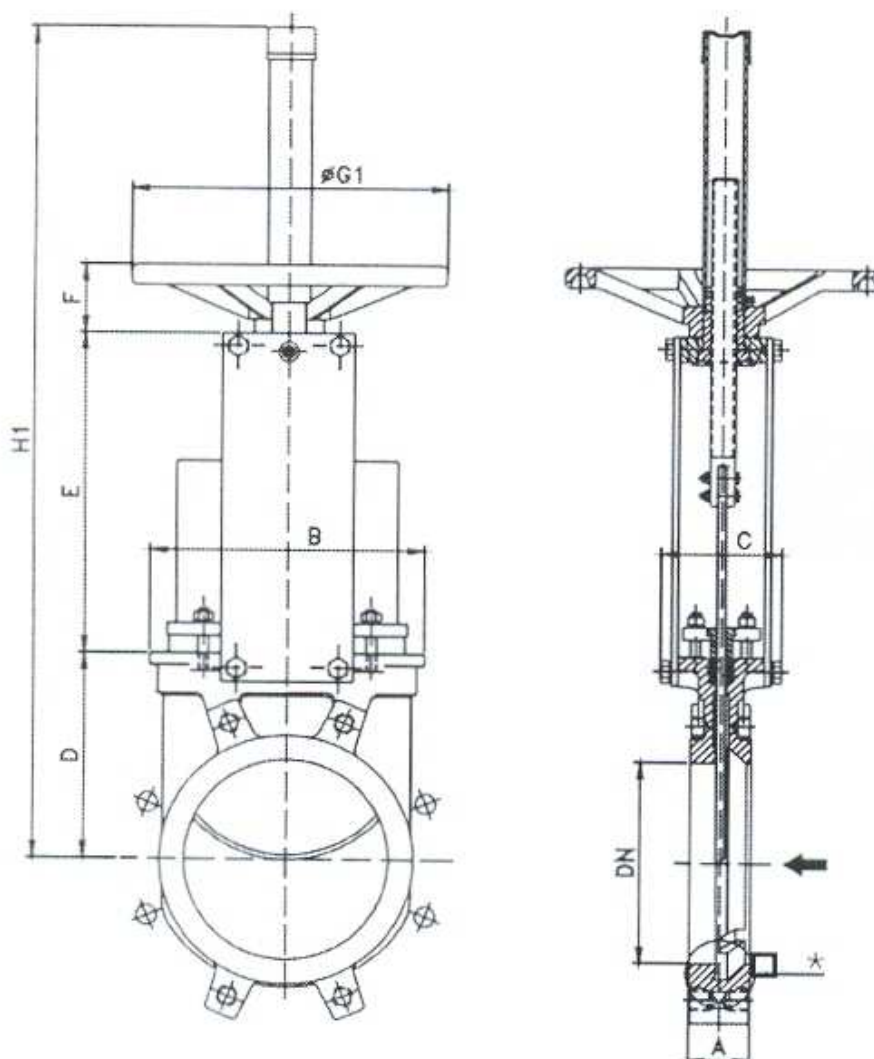

Dimensions Round Gate Valve TYPE Pneumatic Cylinder

DN	ØG2	A	B	C	D	E	G4	H8	H9	K
50	80	40	124	90	105	135	90	170	410	1/4"
65	80	40	139	90	115	152	90	186	453	1/4"
80	80	50	154	90	124	168	90	204	496	1/4"
100	100	50	174	90	140	193	110	225	558	1/4"
125	125	50	192	104	150	217	135	268	635	1/4"
150	125	60	217	104	175	243	135	292	710	1/4"
200	160	60	270	118	205	318	170	355	878	1/4"
250	200	70	326	118	250	373	215	413	1036	3/8"
300	200	70	380	118	300	423	215	463	1186	3/8"
350	250	96	438	193	338	503	274	541	1382	3/8"
400	250	100	493	193	392	553	274	591	1536	3/8"
450	300	106	546	197	432	603	382	669	1704	1/2"
500	300	110	620	197	485	663	382	719	1867	1/2"
600	300	110	714	197	500	793	382	819	2172	1/2"

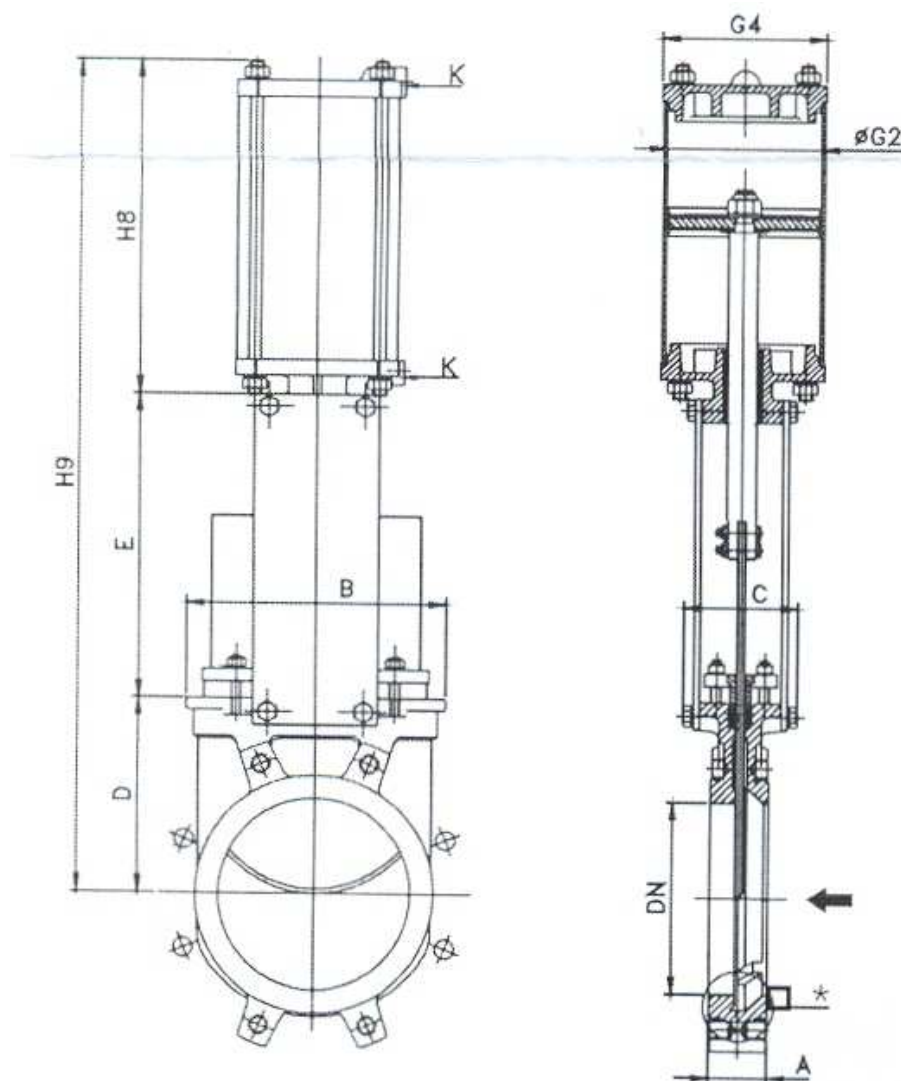

**SEGMENT LOCK TYPE SPS-EP
ELECTRO-PNEUMATIC**

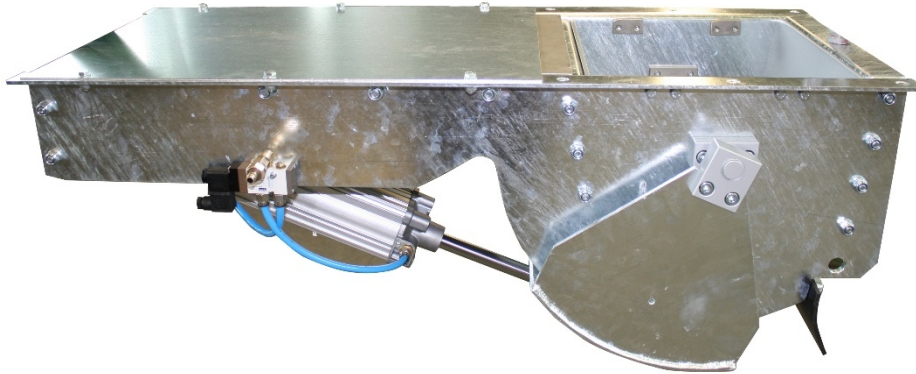

The Stanelle segment lock will be mounted at silo and container outlets and will be used for shut-off and dosing of coarse-grained bulk materials.

**Areas of
Application**

- With clapper and/or with wearing plate
- and/or with emergency sliding plate

Type code:

SPS.../...	Basic version
SPS.../...S	Basic version with wearing plates
SPS.../...K	Basic version with clapper
SPS.../...KS	Basic version with clapper and wearing plates
SPS.../...N	Basic version with emergency sliding plate
SPS.../...NS	Basic version with emergency sliding plate and wearing plates
SPS.../...NK	Basic version with emergency sliding plate and clapper
SPS.../...NKS	Basic version with emergency sliding plate, clapper and wearing plates

Details / Explanation

- Control system with one proximity switch for open or close
- Control system with two proximity switches for open or close
- Control system solenoid valve 5/2: 24V/DC or 230V/AC
- Special solution for dosing on request
- Different drilling pattern on request

Technical data

Table of dimensions

	SPS 350/300		SPS 350/450	
Inlet	350 x 300		350 x 450	
Outlet	230 x 300		230 x 450	
A	350		250	
B	300		450	
C	230		230	
D	400		550	
E	1130		1130	
F	472		472	
G	54		54	
H	360		360	
I	360		510	
Opening time	approx 1,8 sec. by 6 bar		approx 1,8 sec. by 6 bar 3	
Flow rate at	gravel	sand	gravel	Sand
Tons/hour	500	350	820	500
other sizes on request				

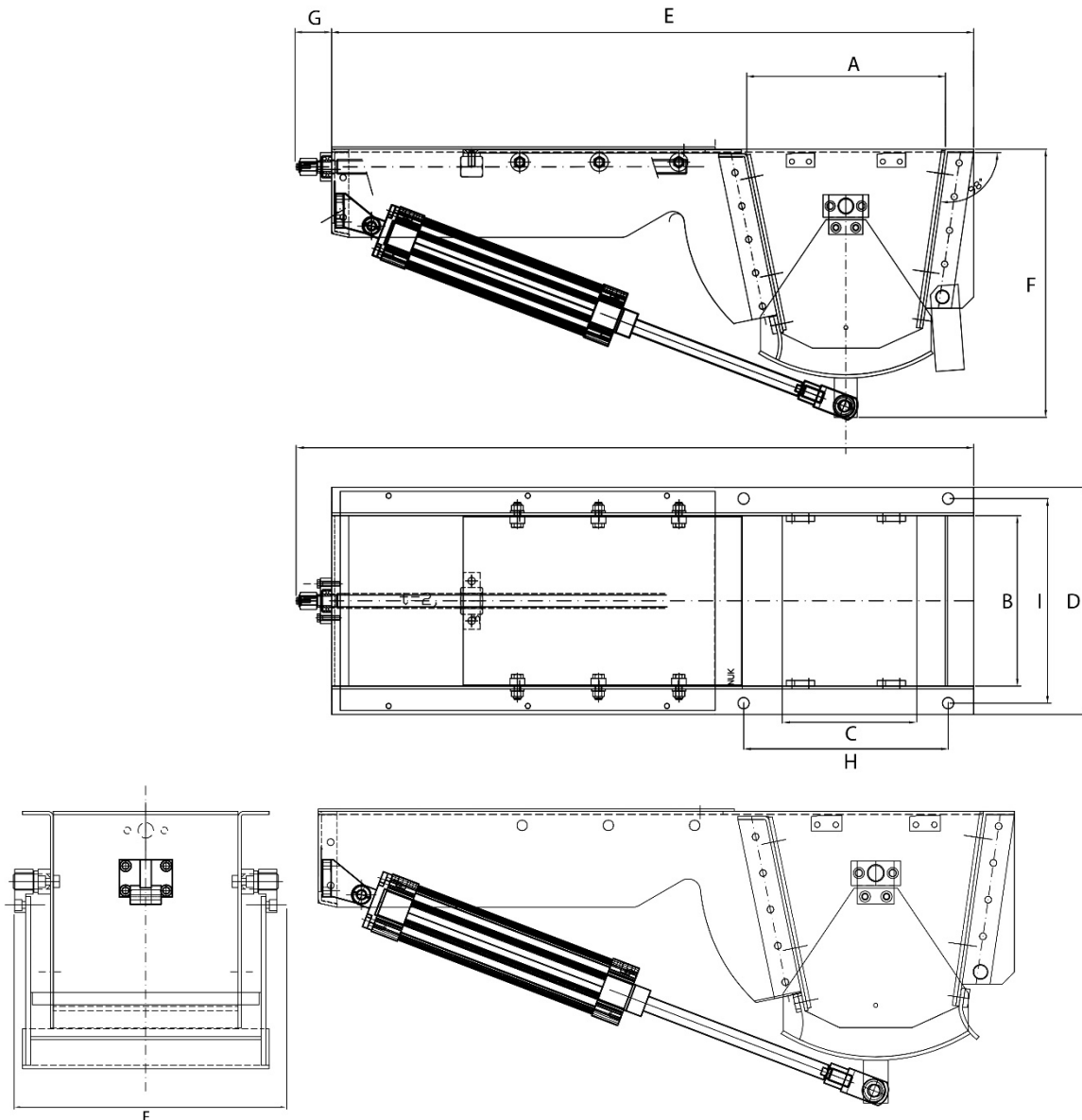

**JET-LOADER QUADRO
WITH LOADING FILTER**



JET- LOADER QUADRO



The Stanelle JET-LOADER TYPE JBM 220 QUADRO is designed for the loading of silo vehicles and containers with free flowing, dry bulk materials. The wide range of applications includes the mining-, chemical- and pharmaceutical industries - even in the explosion-proof areas.

Areas of Application

- Compact construction due to integrated winch motor with factory-set lift-limit switches, slack wire switch guided on a connector switch and filling level indicator
- Robust and abrasion protected, high operating security and maintenance friendly
- Perfectly centered bulk material stream
- Wear protected lift cords that are installed outside the bulk material flow
- Simple installation due to compact construction
- Filling level detection system
- Closure cone
- Loading filter ensures dedusting during silo loading process

Details / Explanation

- Closure cone heater
- Vacuum flap
- Pneumatic internal cleaning

Accessories

- Material grade: Steel or stainless steel. Top coating with hammer tone silver gray (other colors available on request)

Finish

Filling level indicator:

Notice



- **Vibration-Sensor** for light to dusty and grainy bulk materials, up to 10 mm granulate size. Media temperature up to 130° C. Bulk material in Dusty-Ex range zone 20 and temperature range of -20° C to +60° C.

Dimensions

Number of buckets	3	4	5	6	7	8	9	10	11	12
Construction Height ¹⁾	1080	1140	1200	1260	1320	1380	1440	1500	1560	1620
Total length	1900	2190	2480	2770	3060	3350	3640	3930	4220	4510
Lift	820	1050	1280	1510	1740	1970	2200	2430	2660	2890

1) With filling level indicator plus 230 mm.

Notice

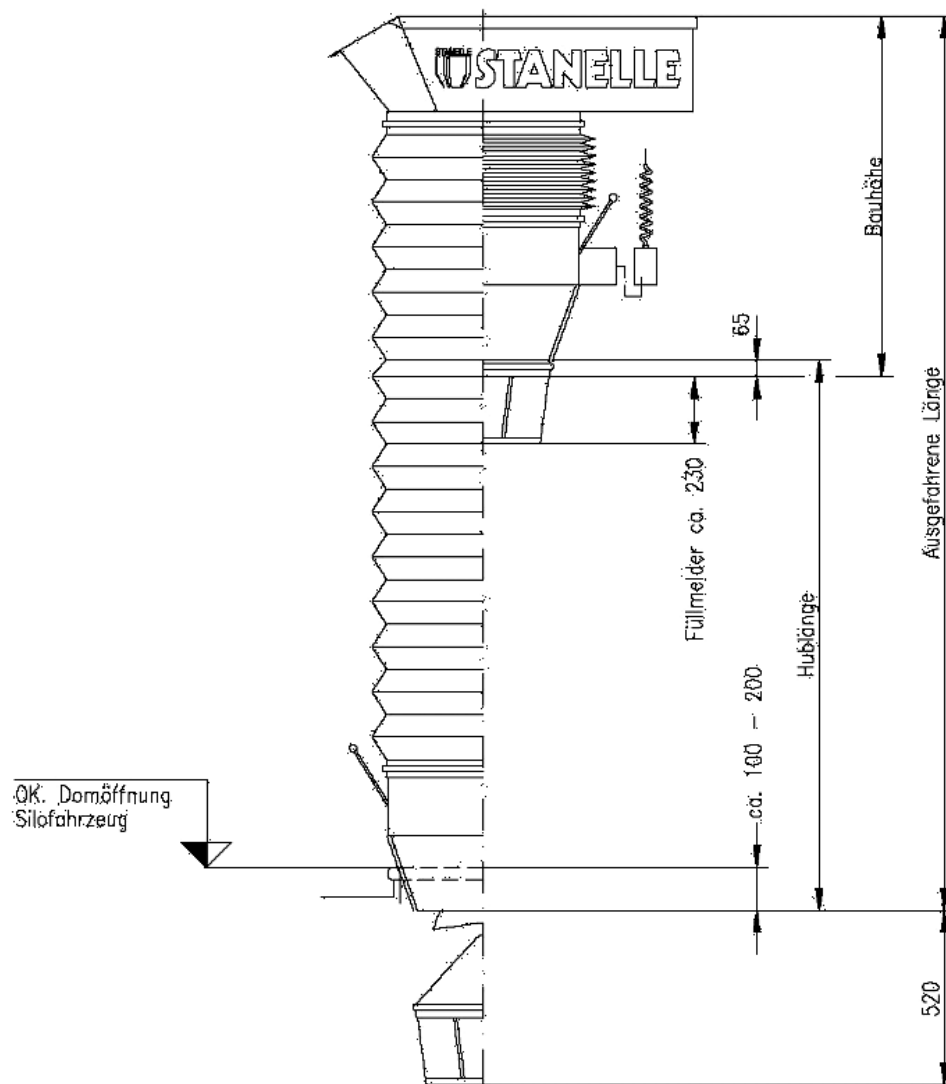

An immersion depth of the top cone into the opening of 150-200 mm needs to be calculated when calibrating the lift or the total length. During the loading process silo vehicles can be lowered for 100 mm, due to the additional weight.

Notice



Technical Data Quadro

Type JBM 220 Quadro	
Nominal diameter	220 mm
For silo domes of	380 – 500 mm
Telescope shaft height	See dimensions above
Lift	See dimensions above
Voltage	400, 500, oder 690 V
Filling level indicator	10 – 250 V AC/DC
Lift motor	1,1 KW

Article number

Type JBM 220 Quadro, Electro motor-driven	Number of buckets	Steel 37-2 ²⁾	Stainless steel
		Article number	Article number
	3	751 10 046	751 10 397
	4	751 10 047	751 10 396
	5	751 10 048	751 10 395
	6 Standard configuration	751 10 049	751 10 355
	7	751 10 097	751 10 113
	8	751 10 050	751 10 573
	9	751 10 051	On inquiry
	10	751 10 052	On inquiry
	11	751 10 053	On inquiry
	12	751 10 054	On inquiry

²⁾ Outside steel parts rust removal degree SA1, zinc-phosphate-grounding approx. 40 µm, top coat hammer tone gray, approx. 40 µm.

Explosion proof design on request.

Notice



Article number

Type JBM 220 Quadro –hand driven–	Article number
For silo dome opening of 380 to 500 mm diameter, compact design, with 5 square steel buckets, closure cone made of cast iron, with outside rubber bellows and reinforced, exchangeable cord holder, 1 vent pipe DN 100/108. Construction height: approx. 1260 mm plus filling level indicator (approx. 230 mm). Telescope shaft length: approx. 1510 mm. External steel parts rust removal degree SA1, zinc-phosphate-grounding, approx. 40 µm, top coat hammer tone gray, approx. 40 µm.	751 10 311

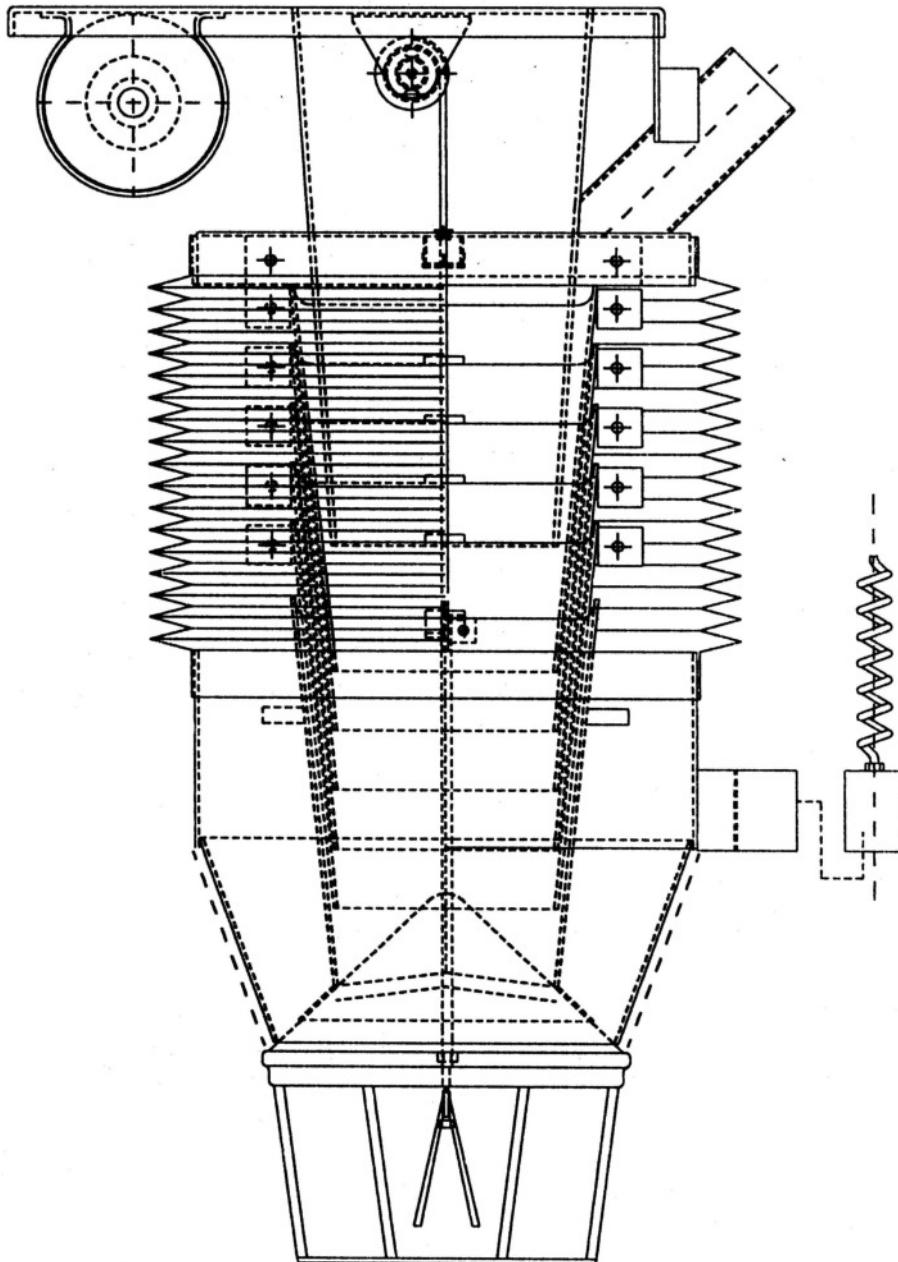

Quadro hand driven

Accessories

Filling level indicator	Type	Steel 37-2	High-grade Steel
With protection cage, electric supply cord, running on clamp inside the loader cone, fully installed, mounted to bottom side of closure cone. Construction height is extended for approx. 230 mm.		Article number	Article number
	Vibration sensor: Model 10 – 250 V AC/DC with relay contact	751 10 485	751 10 487
	Vibration sensor with separate electronic: Model 10 – 250 V AC/DC with relay contact	751 10 557	751 10 488
	Rotatable flank detector: Model 230 V	751 10 068	751 10 068
	Rotatable flank detector: Model 24 V DC	751 10 069	751 10 069
	Vibration sensor: for application in Ex-range Zone 20, with separated electronic and signal evaluator	751 10 511	751 10 124

Article number

Closure cone heater	Article number
Self regulating heater, included in the closure cone on clamp over helix cable inside the loader, shot-down at approx. +60°C, Voltage 230 V 50 Hz	751 10 058

Article number

Pneumatic internal cleaning	Article number
Pneumatic dedusting system, inside buckets und outside rubber bellows are ventilated and cleaned; the same applies to the exhaust area in the top cone	751 10 194

Article number

Vacuum flap	Article number
Installed on the vent pipe of the loader; connected to a dedusting system	751 10 131

JET-LOADER TELE-RONDO



The Stanelle loader **TYPE JBM 200 TELE-RONDO** is a special loader for the charging of silo vehicles which are to be loaded with easily de-mixable bulk goods such as, for example, dry mortar.

- Integrated level indicators automatically adjust the telescope length of the loader according to the actual loading level
- In conjunction with the Stanelle **longitudinal & cross traversing unit**, the TELE-RONDO is the perfect loading solution for special bulk materials, which tend to de-mix.
- Two max. level indicators guarantee the shutdown of the silo system when the desired filling level is reached
- When the TELE-RONDO is raised the closure cone prevents after-trickling of bulk material and the intrusion of air and humidity into the loader.

- Material grade: steel or stainless steel with top coating hammer tone silver gray (more colors available on request)

Areas of Application

Details / Explanation

Finish

LOADING PROCESS WITH THE JET-LOADER TELE-RONDO

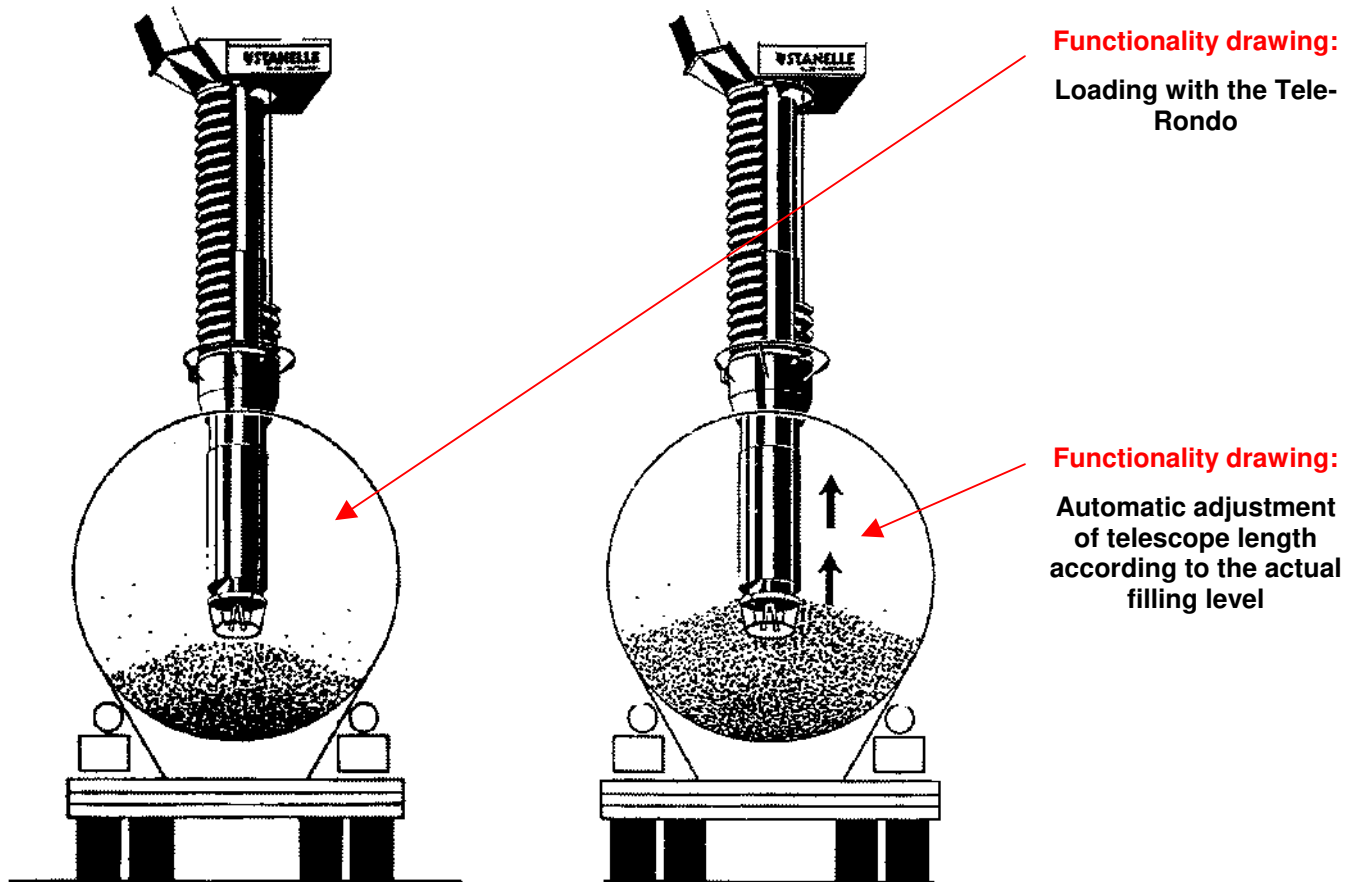

Bulk material with different weights and big heights of fall cause de-mixing problems resulting in lower quality of the bulk material.

By using the **TELE-RONDO Type JBM 200** when loading silo vehicles with silo domes of 350 to 500 mm diameter, the de-mixing of heterogeneous bulk material with particles of different granulation and weights (like dry mortar) is prevented.

Dimensions

	Standard	Replace version – short version (for standard Quadro)
A	1800	1490
B	4609	3675
Lift	2839	2215

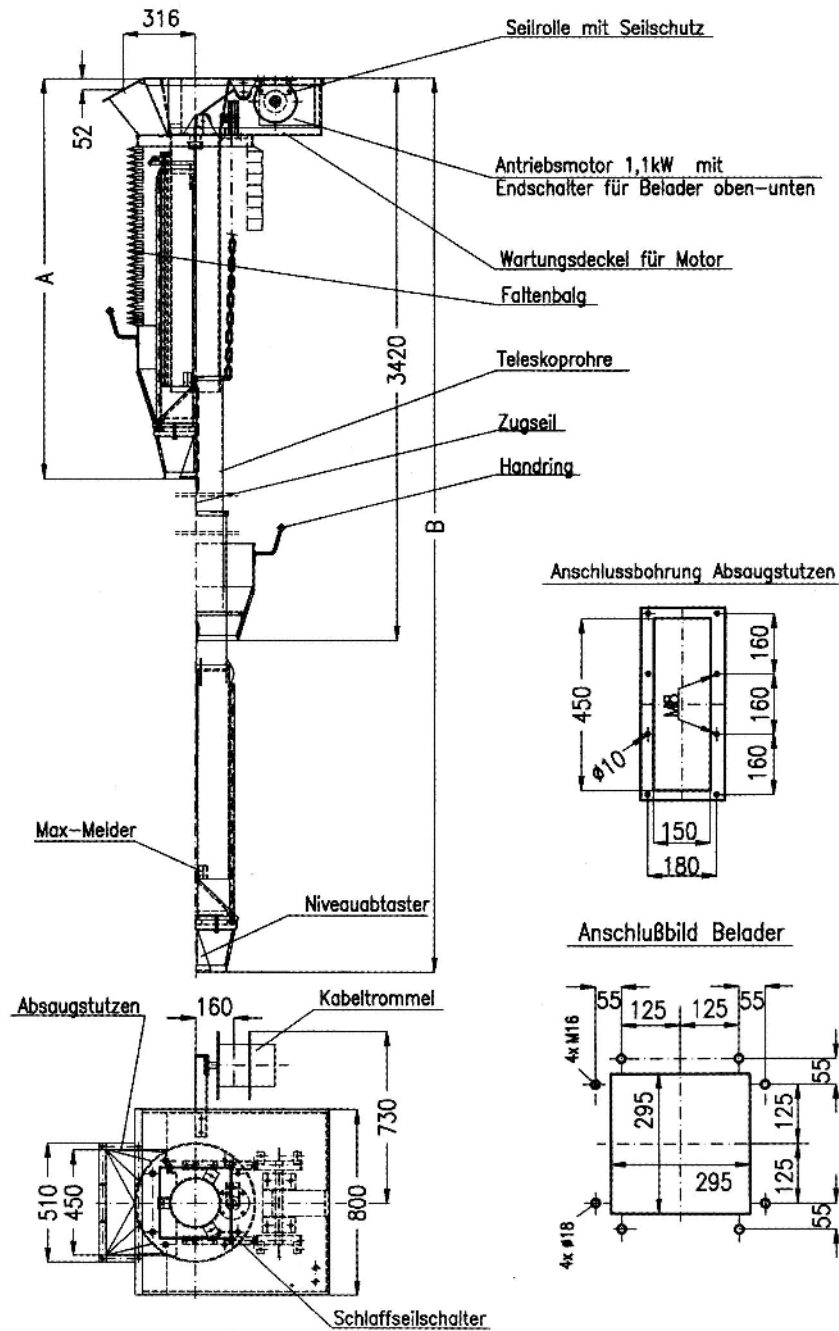

Technical Data Tele-Rondo

Type JBM 200 Tele-Rondo	
Nominal diameter	200 mm
Flow rate	100 m ³ / h
Bottom edge of top cone (expanded)	approx. 3400 mm
Total length, incl. level indicator	approx. 4505 mm
Telescope length (tube)	approx. 2735 mm
Lift motor	1,1 KW
Voltage	400, 500, or 690 V / 50 Hz
Voltage of filling level sensor	24 V / DC

Article Number

Type JBM 200 Tele-Rondo-	Article number
Standard	751 10 004
Short version	751 10 248

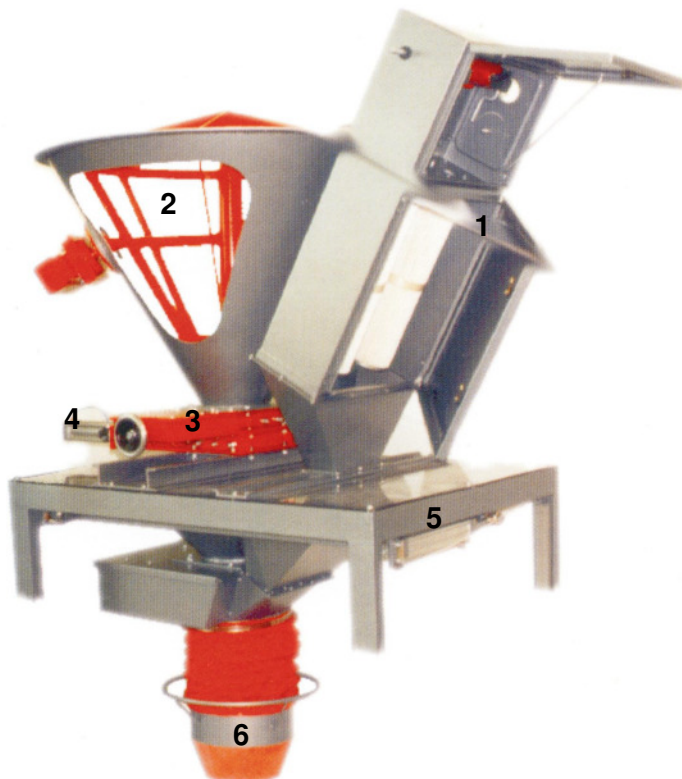

**Recommended
additional accessories
for the
Tele-Rondo**

- 1 Loader filter**
- 2 Discharge vibrating cage**
- 3 Emergency flat gate**
- 4 Pneumatic flat gate**
- 5 Longitudinal and cross traversing unit**
- 6 Tele-Rondo**

JET-LOADER RONDO – HAND DRIVEN

The Jet-loader type JBM 250 Rondo is used to load open road and railway vehicles as well as silo vehicles and containers with free flowing, dry, dusty to pebbly bulk materials.

Areas of Application

- Compact design with round, wear resistant plastic buckets
- Top cone with rubber coating
- External rubber bellows, hand winch with deflection pulley
- Filling level indicator
- External towing ropes ensure easy replacement of the rubber bellows and internal buckets.
- Ingress protection IP 54

- Material grade: Steel or Stainless Steel, top coat with hammer tone silver gray
 (more colors available on request)

Details / Explanation

Finish

Article Number

Type JBM 250 Rondo –hand driven–	Article number
For silo dome opening of 380 mm to 500 mm diameter, for loading of dry, dusty bulk materials, with 5 round inner buckets made of plastic, open at the bottom, without impact disk, with rubber bellows, 1 vent pipe DN 100/108, with winch, deflection pulley and approx. 15 m cable. Construction height: approx. 930 mm plus filling level indicator (ca. 200 mm) Telescope shaft length: approx. 1450 mm External steel parts rust removal degree SA1, zinc-phosphate-grounding, approx. 40 µm, top coat hammer tone gray, ca. 40 µm.	751 10 138

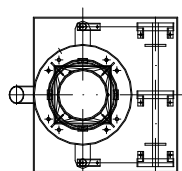
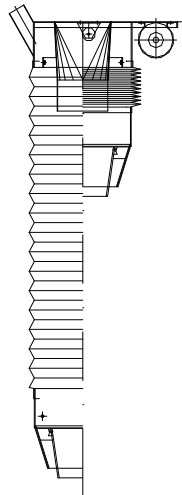

Scale Drawing
JBM 250
hand driven

JET-LOADER RONDO –MOTOR-DRIVEN–



The Jet-loader type JBM 250 Rondo is used to load open road and railway vehicles as well as silo vehicles and containers with free flowing, dry, dusty to pebbly bulk materials.

Areas of Application

- Compact design with round, wear resistant plastic buckets
- Top cone with rubber coating
- External rubber bellows, hand winch with deflection pulley
- Filling level indicator
- External towing ropes ensure easy replacement of the rubber bellows and internal buckets.
- Ingress protection IP 54

Details / Explanation

Material grade: Steel or Stainless Steel, top coat with hammer tone silver gray (more colors available on request)

Finish

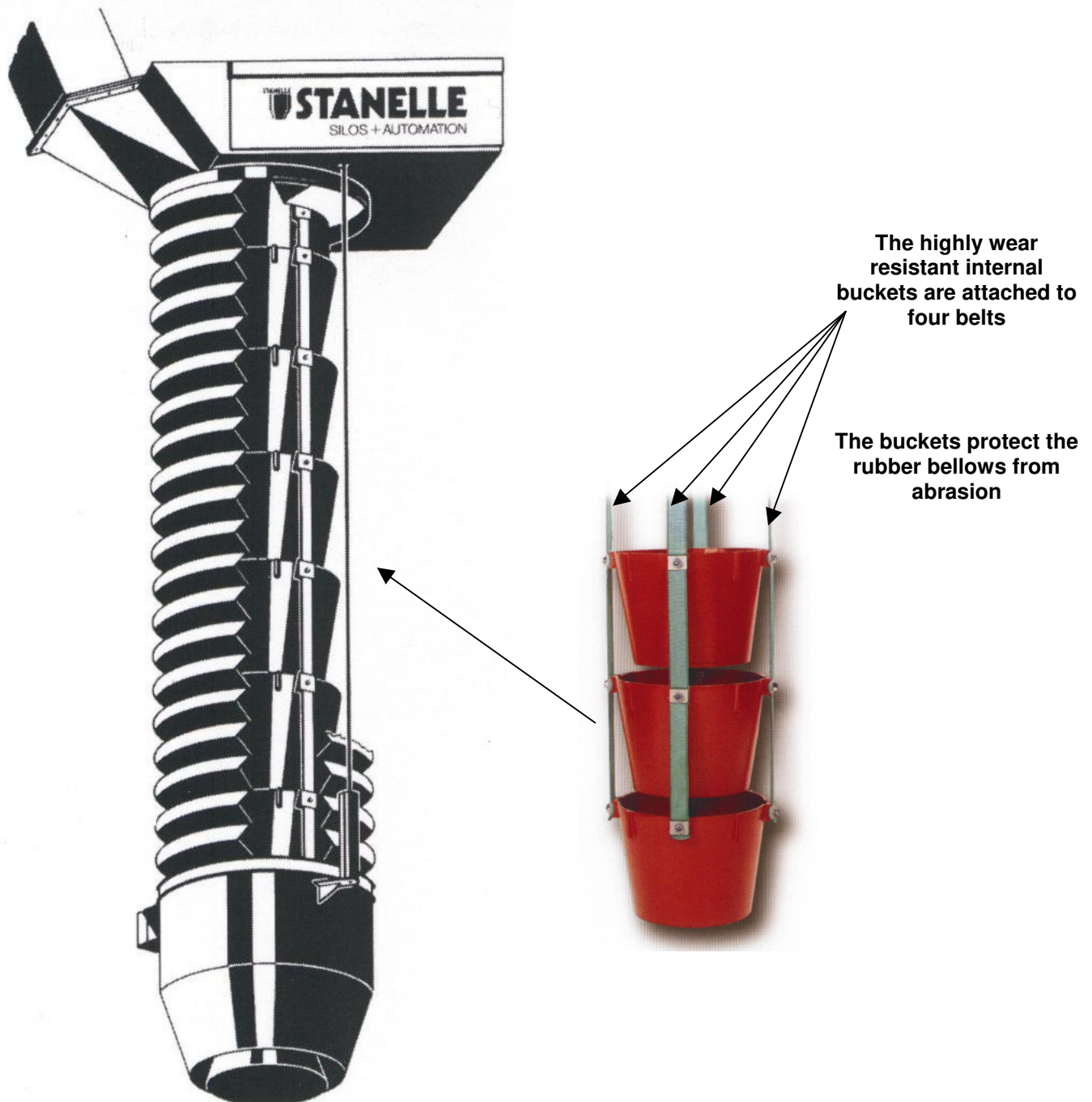

Filling level indicator:

- **Vibration-Sensor** for light to dusty and grainy bulk materials, up to 10 mm granulate size. Media temperature up to 130° C. Bulk material in Dusty-Ex range zone 20 and temperature range of -20° C to +60° C.

Notice



Dimensions

Number of buckets	3	4	5	6	7	8	9	10	11	12	13	14
Construction Height ¹⁾	760	820	880	940	1000	1060	1120	1180	1240	1300	1360	1420
Total length	1520	1760	2000	2240	2480	2720	2960	3200	3440	3680	3920	4160
Lift	760	940	1120	1300	1480	1660	1840	2020	2200	2380	2560	2740

1) With filling level indicator plus 230 mm.

Notice

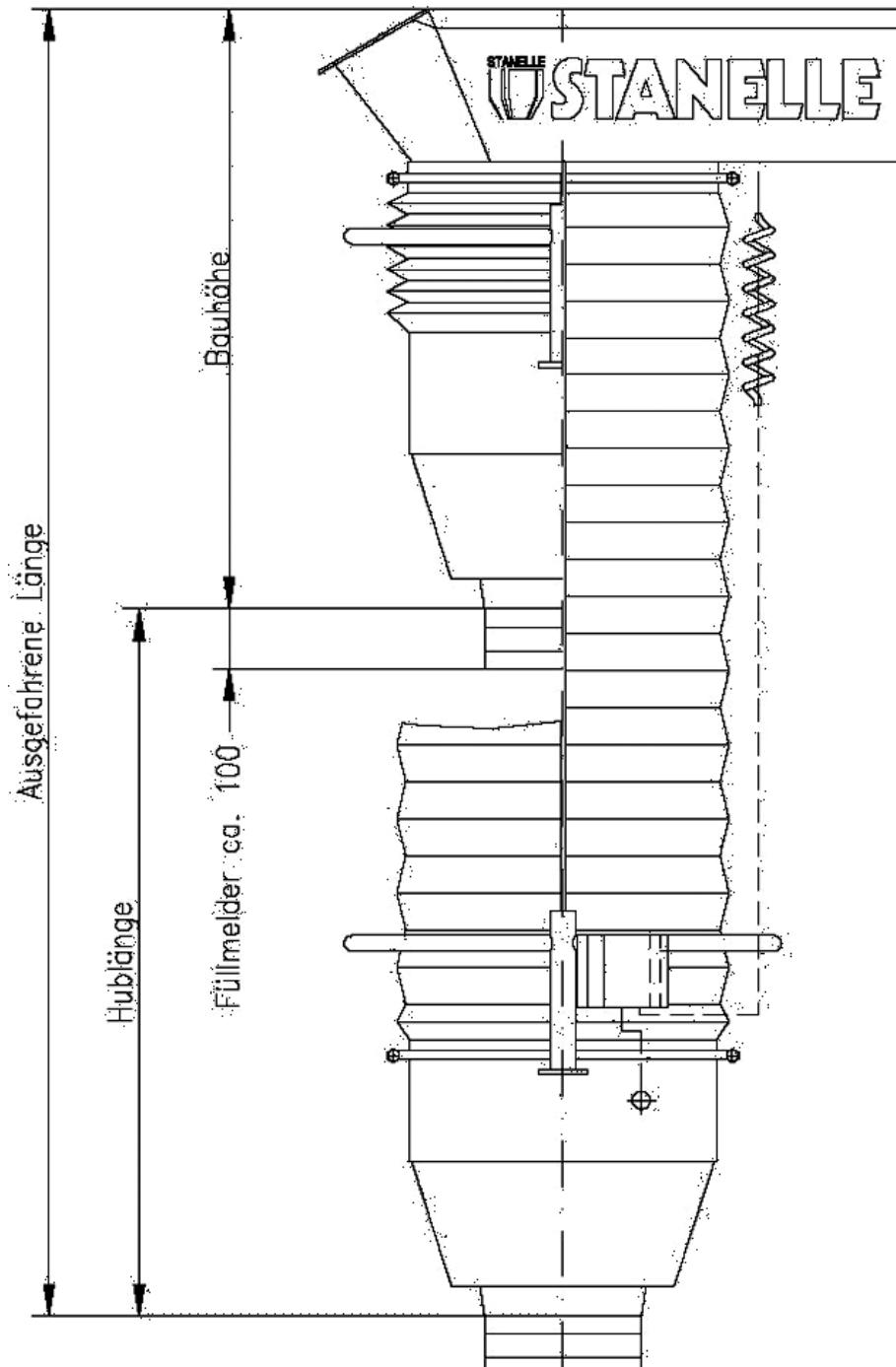

Technical Data Rondo

Typ JBM 250 Rondo	
Nominal diameter	250 mm
For silo domes of	380 – 500 mm
Telescope shaft height	See measurement table above
Lift	See measurement table above
Lift motor	1,1 KW oder 2 x 1,1 KW
Voltage	400, 500, oder 690 V

Article Number

Type JBM 250 Rondo – electro motor-driven –	Number of buckets	Article number
	3	751 10 278
	4	751 10 244
	5	751 10 381
	6	751 10 382
	7	751 10 011
	8	751 10 009
	9	751 10 262
	10	751 10 263
	11	751 10 264
	12	751 10 265
	13	751 10 082
	14	751 10 083

Accessories for Rondo

Dust skirt	Article Number
To avoid dust development when loading dusty bulk materials, attached to the loader cone Diameter: 515/ 800 mm Height: approx. 500 mm Material: polyester fabric	751 10 191

Scale Drawing

Dust skirt

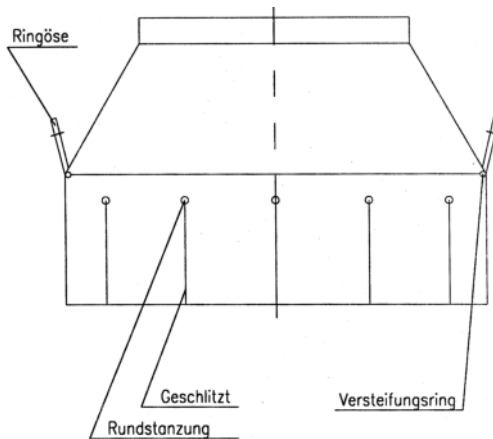

Variable Dust Skirt	Article Number
When loading silo vehicles and open trucks using the loader TYPE Rondo, the variable dust skirt can be lowered with the filling cone or stay attached to the loader head	751 10 084

Variable dust skirt



Filling level indicator			Article number	Article number
With protection cage, electric supply cord, running on clamp inside the loader cone, fully installed, mounted to bottom side of closure cone. Construction height is extended for approx. 100 mm. Voltage: Design 10 - 250 V AC/DC Design 10- 55 V DC, PNP-switchable	Filling level indicator		Steel (St 37)	Stainless Steel (1.4301)
	Max. temperature of +130° C.	Vibration sensor with separate electronic	751 10 486	751 10 488
	Ex-proof, Max. temperature +60° C.	Vibration sensor for application in Ex-range Zone 20, with separate electronic and signal evaluator.	751 10 523	

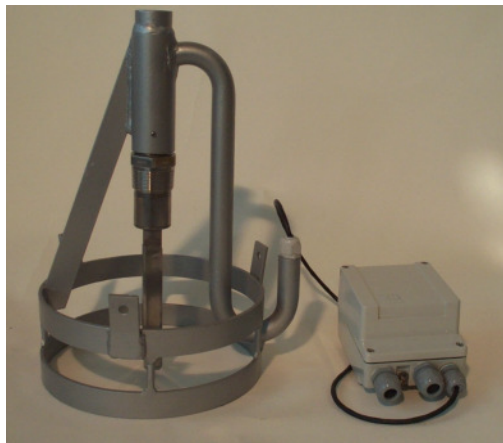

Level indicator

JET-LOADER RONDO 300 M SERIE

Overview of models	
<p>RONDO 300 M without breech cone</p> <ul style="list-style-type: none"> • Option (DT) Turntable • Option ((VAR) Variable dust skirt • Option (R) Vibrator <p>All options are freely combinable.</p>	
<p>RONDO 300 MVK with breech cone</p> <ul style="list-style-type: none"> • Option (DT) Turntable • Option (R) Vibrator 	
<p>RONDO 300 MSG only with dust bell</p> <p>Without turntable Without breech cone</p>	

JET-LOADER RONDO 300 M



The loader type Rondo 300 M is suitable for loading open road and rail vehicles, silo vehicles and containers with free-flowing, dry, dusty to chippy bulk materials.

Areas of Application

- Compact design with round, wear resistant plastic buckets
- Top cone with rubber coating
- External rubber bellows, hand winch with deflection pulley
- Filling level indicator
- External towing ropes ensure easy replacement of the rubber bellows and internal buckets.
- Ingress protection IP 54

Details / design

- Rust removal: SA 2,5
- Primer: 2K; 40µm
- Top coat: 2K; RAL 9006; 40µm

Finish

Depending on bulk product , different level sensors will be installed

Note



- **Vibration-Sensor** for light and dusty bulk products, up to 10 mm grain size. Bulk temperatures up to 130° C. ATEX zone 20 with temperature area -20° C to +60° C.

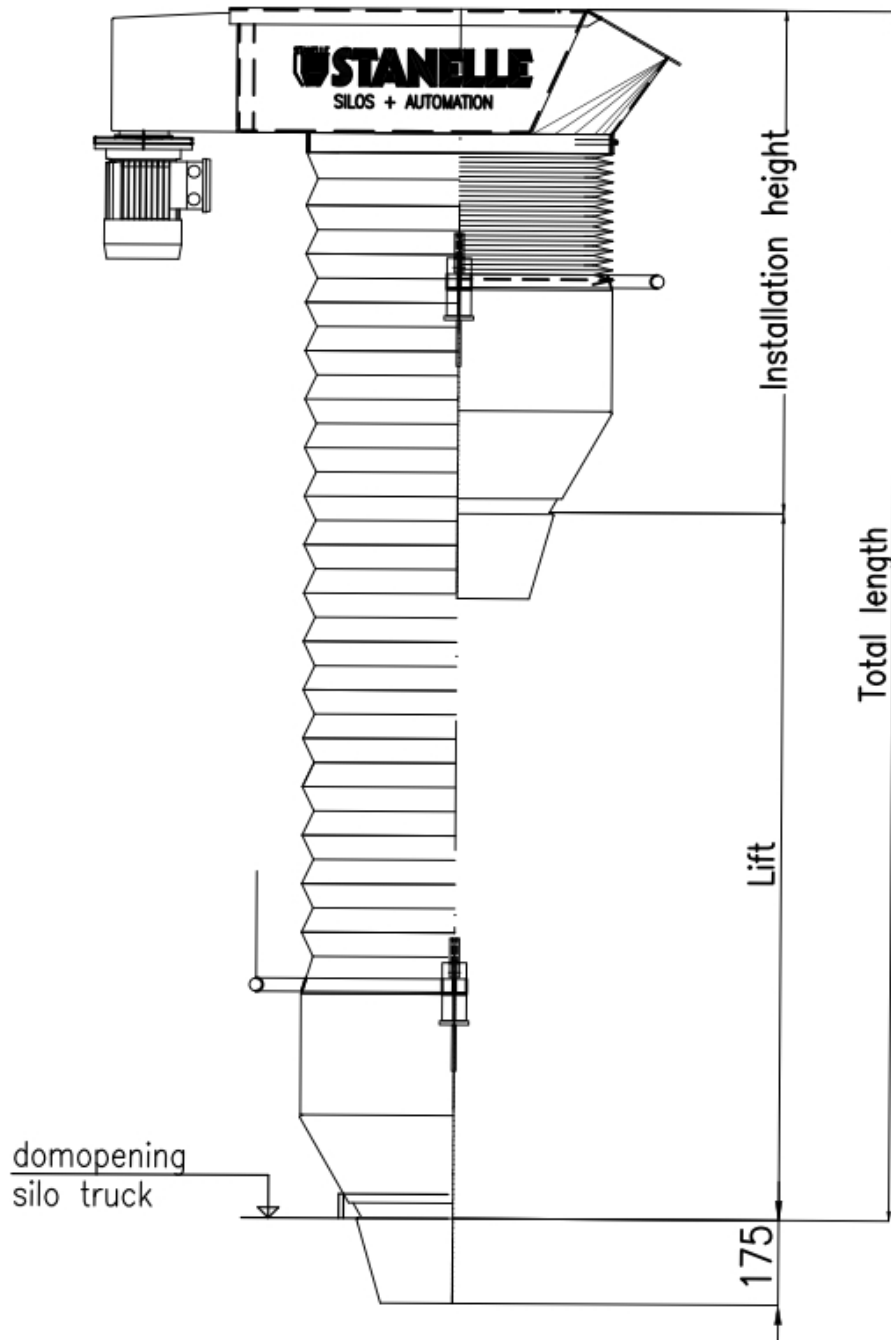

Dimensions

Number of buckets	3	4	5	6	7
Installation height ¹⁾	905	975	1045	1115	1185
Total length	1855	2175	2495	2815	3135
Lift	950	1200	1450	1700	1950

Number of buckets	8	9	10	11	12
Installation height ¹⁾	1255	1325	1395	1465	1535
Total length	3455	3775	4095	4415	4735
Lift	2200	2450	2700	2950	3200

¹⁾ additional installation height 175 mm in connection with level sensor

Note



Technical data

JET BELADER Type RONDO 300 M	
Size	300 mm
For Silodomes of	Ø 400 – 500 mm
Telescope shaft height	see dimension table
Stroke	see dimension table
Lift motor	0,75 kW / 2 x 0.75 kW (depending on application)
Voltage	400, 500, oder 690 V

JET BELADER Type RONDO 300 M	
Number of bucket	Article number
3	751 11 171
4	751 11 201
5	751 11 202
6	751 11 203
7	751 11 204
8	751 11 205
9	751 11 206
10	751 11 207
11	751 11 208
12	751 11 209
13	751 11 210

Options	Article number
Variable dust skirt	751 10 664
Support rack with vibrator	751 11 127
Rotating plate	751 11 093-01

JET-LOADER RONDO 300 M VK WITH CLOSING CONE



The loader type RONDO 300 M VK (closing cone) is suitable for loading silo vehicles and containers with dry, free-flowing bulk materials. The range of applications includes the building materials, mining, chemical, power generation, water and waste water and pharmaceutical industries.

Areas of Application

- Compact construction due to integrated winch motor with factory-set lift-limit
- switches, slack wire switch guided on a connector switch and filling level indicator
- Robust and abrasion protected, high operating security and maintenance friendly
- Perfectly centered bulk material stream
- Wear protected lift cords that are installed outside the bulk material flow
- Simple installation due to compact construction
- Filling level detection system
- Closure cone
- Loading filter ensures dedusting during silo loading process

Details / design

- Rust removal: SA 2,5
- Primer: 2K; 40µm
- Top coat: 2K; RAL 9006; 40µm

Finish

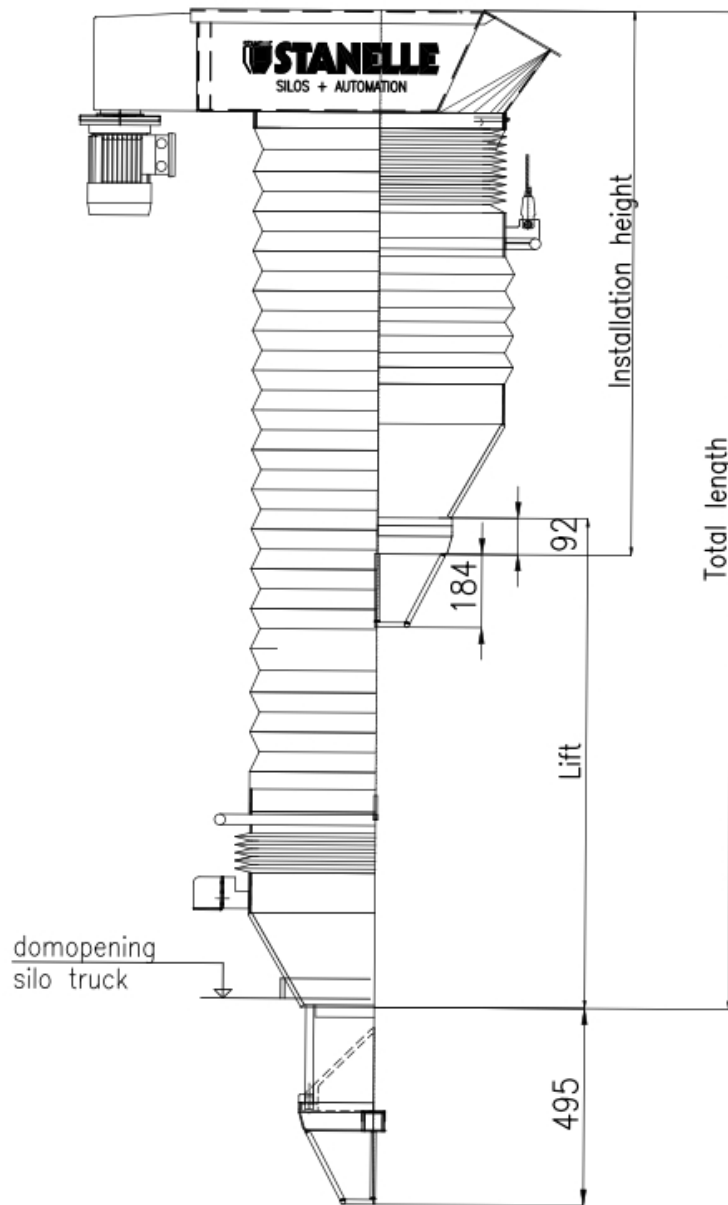

Depending on bulk product , different level sensors will be installed

- **Vibration-Sensor** for light and dusty bulk products, up to 10 mm grain size. Bulk temperatures up to 130° C. ATEX zone 20 with temperature area -20° C to +60° C.

Note



Dimensions

Number of buckets	4	5	6	7	8
Installation height ¹⁾	1300	1370	1440	1510	1580
Telescopic length	2185	2505	2825	3145	3465
Lift	980	1230	1480	1730	1980

Number of buckets	9	10	11	12	13
Installation height ¹⁾	1650	1720	1790	1860	1930
Telescopic length	3785	4105	4425	4745	5065
Lift	2230	2480	2730	2980	3230

¹⁾ additional installation height 175 mm in connection with level sensor

Note



Technical data

JET BELADER Type RONDO 300 M VK	
Size	300 mm
For silodome of	Ø 400 – 500 mm
Telescopic length	see dimension table
Lift	see dimension table
Lift motor	0,75 kW / 2 x 0.75 kW (depending on application)
Voltage	400, 500, oder 690 V

JET BELADER Type RONDO 300 M VK	
Number of buckets	Article number
4	751 11 156
5	751 11 128
6	751 11 105
7	751 11 161
8	751 11 174
9	751 11 211
10	751 11 212
11	751 11 213
12	751 11 214
13	751 11 215

Options	Article number
Support rack with vibrator	751 11 127
Rotating plate	751 11 093-01

JET-BELADER RONDO 300 M SG WITH DUST SKIRT



The loader type RONDO 300 M SG (dust cover) is suitable for loading open road and rail vehicles with dry, free-flowing bulk materials. The range of applications includes the building materials, mining, chemical, power generation, water and waste water and pharmaceutical industries.

Areas of Application

- Compact construction due to integrated winch motor with factory-set lift-limit
- switches, slack wire switch guided on a connector switch and filling level indicator
- Robust and abrasion protected, high operating security and maintenance friendly
- Perfectly centered bulk material stream
- Wear protected lift cords that are installed outside the bulk material flow
- Simple installation due to compact construction
- Filling level detection system
- Dust skirt Ø 1150 mm double layer.
- Dedusting with Filter.

Details / design

- Rust removal: SA 2,5
- Primer: 2K; 40µm
- Top coat: 2K; RAL 9006; 40µm

Finish

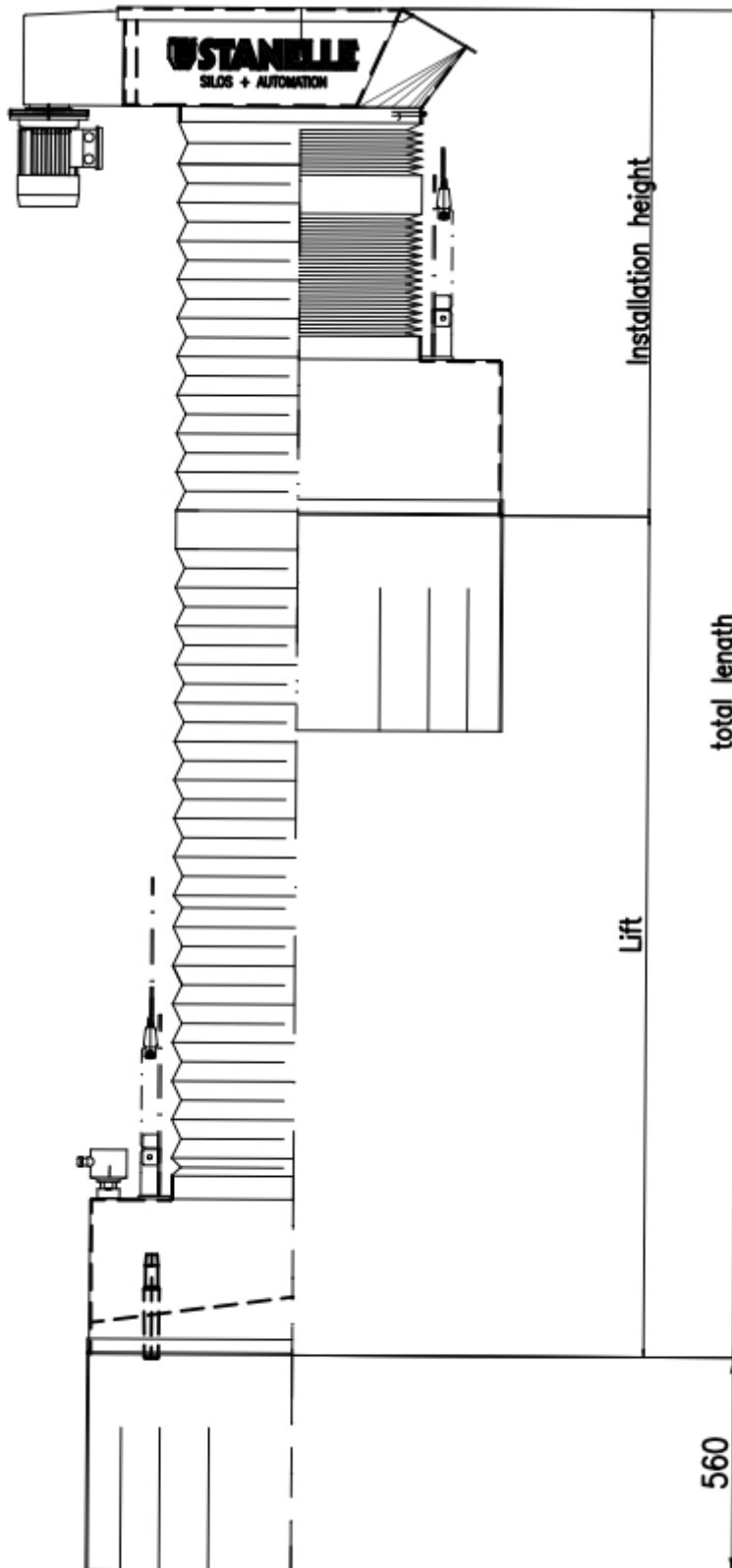

Depending on bulk product , different level sensors will be installed



- **Vibration-Sensor** for light and dusty bulk products, up to 10 mm grain size. Bulk temperatures up to 130° C. ATEX zone 20 with temperature area -20° C to +60° C.

Dimensions

Number of buckets	8	9	10	11	12	13
Installation height ¹⁾	1875	1945	2015	2085	2155	2225
Teleopic length	3497	3817	4137	4457	4817	5097
Lift	2182	2432	2682	2932	3182	3432

¹⁾ additional installation height 175 mm in connection with level sensor

Note



Technical Data

JET BELADER Type RONDO 300 M SG	
Size	300 mm
Teleopic length	See dimension sheet
Lift	See dimension sheet
Lift motor	0,75 kW / 2 x 0,75 kW (depending on application)
Voltage	400, 500, oder 690 V

Article Number

JET BELADER Type RONDO 300 M SG	
Number of buckets	Article number
8	751 11 146
9	751 11 140
10	751 11 147
11	751 11 148
12	751 11 150
13	751 11 149

GRAVEL LOADER RONDO

DN 350, 500



The loader type **RONDO DN 350, 500** is a special loader used to load open trucks and railway vehicles as well as silo vehicles and containers with stone dust, chips and gravel

Areas of Application

- Design with extended lift can be used for ship or waste dump loading
- With the extraction connector a required exhaust volume of approx. 2000-3000 m³/h/lfm can be sucked off with a compatible dedusting device.
- The Rondo Type DN 350, 500 has a loading capacity of 250 -300 m³ / h for stone dust and sand.
- The gravel and hard stone industry is the ideal application area for the Rondo Type DN 350, 500, with its highly abrasion resistant components.
- The rotatable and easily exchangeable protective tubes made of Hardox 400 increase the life time significantly. Wall thickness up to **10 mm** and the use of special steel lower the operating and maintenance costs.

Details / Explanation

- External parts are sand blasted, grounded and have a hammer tone silver grey color or they are coated with premium paint.

Finish

Dimensions

Rondo DN	350	500
A Construction height	1600	
B Lift	3140	3000
C	1000	1260
D	1390	1485
E	200	
F	1000	
G	600	
H	600	600

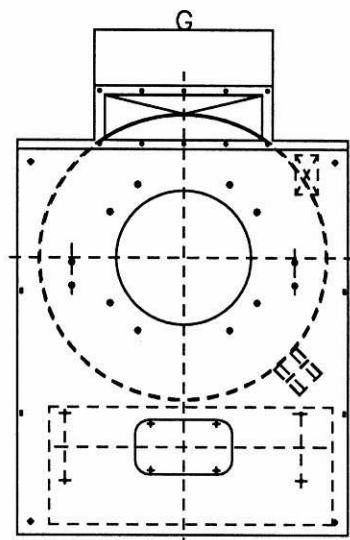
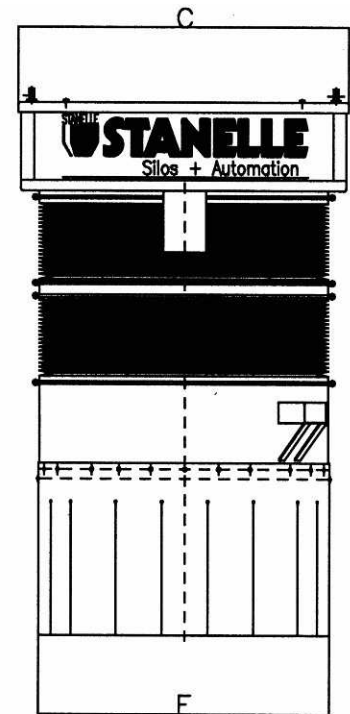
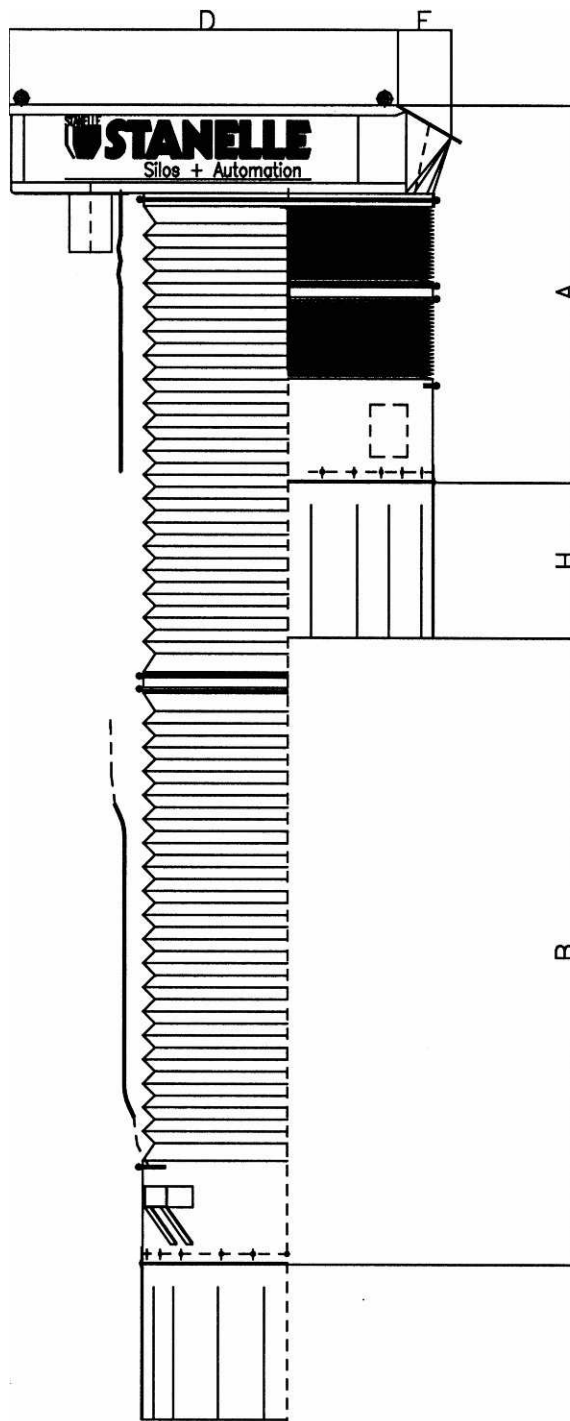

Technical Data Rondo DN 350, 500

Type Rondo DN	350	500
Nominal diameter	DN 350 – 500 mm	
Loading capacity	250 m ³ / h	300 m ³ / h
Construction height	1600 mm	
Telescope shaft length	3140 mm	3000 mm
Suction capacity	6000 m ³ / h	7000 m ³ / h
Voltage	400, 500, or 690 V	
Winch motor	0,74 kW	1,1 kW
Dust skirt	Segment individually replaceable	
Filling level indicator	capacitive	

Article Number

Type JBM Rondo DN 350	Article number
	751 10 547

Article Number

Type JBM Rondo DN 500	Article number
	751 10 073

GRAVEL LOADER RONDO

DN 600, 800



The loader type **RONDO DN 600, 800** are special loaders used to load open trucks and railway vehicles as well as silo vehicles and containers with stone dust, chips and gravel

Areas of Application

- Design with extended lift can be used for ship or waste dump loading.
- With the extraction connector a required exhaust volume of approx. 2000-3000 m³/h/lfm can be sucked off with a compatible dedusting device.
- The **Rondo Type DN 600, 800** has a loading capacity of 500-800 m³ / h for stone dust and sand.
- The gravel and hard stone industry is the ideal application area for the **Rondo Type DN 600, 800**, with its highly abrasion resistant components.
- The rotatable and easily exchangeable protective tubes made of Hardox 400 increase the life time significantly. Wall thickness up to **20 mm** and the use of special steel lower the operating and maintenance costs.

Details / Explanation

- External parts are sand blasted, grounded and have a hammer tone silver gray color or they are coated with premium paint.

Finish

Dimensions

Rondo DN	600	800
A Construction Height	1600	
B Lift	3000	
C	1800	2000
D	1735	1935
E	300	
F	1350	1500
G	600	

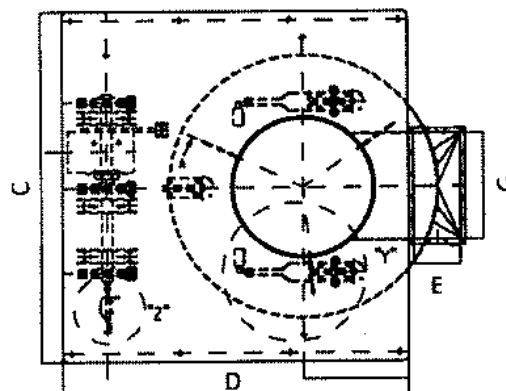
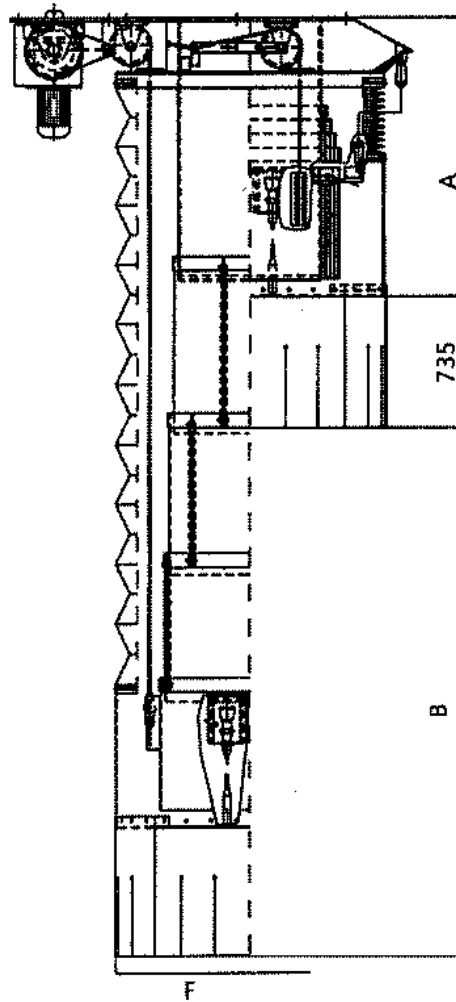

Technical Data Rondo DN 600, 800

Type Rondo DN	600	800
Nominal diameter	DN 600 – 800 mm	
Loading capacity	500 – 800 m ³ / h	
Construction height	1600 mm	
Telescope shaft length	3000 mm	
Suction capacity	10.000 m ³ / h	12.000 m ³ / h
Voltage	400, 500, or 690 V	
Winch motor	1,5 kW	

Article Number

Type Rondo DN 600	Article number
<p>Compact design, abrasion resistant telescope pipes made of Hardox 400, loader head attached to solid chains, open bottom, without deflector plate. Loader head with opening DN 600 and abrasion resistant pipes with 6 mm wall thickness, air outlet 300 x 600 mm, 30° incline. Built in winch, 3 pulley wheels, end switch, slack rope switch as well as lift limit switch.</p> <p>Rubber bellows and double-layer dedusting skirt made of reinforced rubber, diameter Ø 1350 mm, with individual replaceable segments.</p> <p>2 capacity sensors for filling level indication, height adjustable:</p> <p>Nominal diameter: 600 mm Lift motor: 1,5 kW - 400 V, 50 Hz Construction height: approx. 1600 mm plus dedusting skirt 600 mm Telescope shaft length: approx. 3000 mm</p> <p>External steel parts rust removal SA 1, zinc-phosphate-grounding, approx. 40 µm, top coat hammer tone gray, approx. 40 µm.</p>	751 10 296

Extras

Reinforced pipe – for initial equipment –	Article number
<p>For extra splintery and abrasive bulk materials Pipe wall thickness 20 mm instead of 10 mm.</p> <p>for Rondo DN 600, width approx. 600 mm, length 1500 mm</p>	751 10 249
- as spare part -	751 10 298

Article Number

Type Rondo DN 800	Article number
Compact design, abrasion resistant telescope tubes made of Hardox 400, loader head attached to solid chains, open bottom, without deflector plate. Loader head with opening DN 800 and abrasion resistant pipes with 10 mm wall thickness, air outlet 300 x 800 mm, 30° incline. Built in winch, 3 pulley wheels, end switch, slack rope switch as well as lift limit switch. Rubber bellows and double-layer dedusting skirt made of reinforced rubber, diameter Ø 1500 mm, with individual replaceable segments. 2 capacity sensors for filling level indication, height adjustable: Nominal diameter: 800 mm Lift motor: 1,5 kW - 400 V, 50 Hz Construction height: approx. 1600 mm plus dedusting skirt 600 mm Telescope shaft length: approx. 3000 mm External steel parts rust removal SA 1, zinc-phosphate-grounding, approx. 40 µm, top coated hammer tone gray, approx. 40 µm.	751 10 125
Various telescope shaft lengths and designs available	On request

Extras

Reinforced pipe – for initial equipment –	Article number
For extra splintery and abrasive bulk materials Pipe wall thickness 20 mm instead of 10 mm.	751 10 293
for Rondo DN 800, width approx. 760 mm, length 1500 mm	
- as spare part -	751 10 297

STOCKPILE LOADER JBM 350H

The loader type JBM 350H is a specific loader for loading dry, free flowing bulk materials on stockpiles.

Areas of Application

- **Loader head**, designed to be hooked to a change-over chute with an outlet of Ø 350 mm.
- **Inlet pipe** made of St 37-2 (10 mm wall thickness)
- **Lift drive** with cable drums for 8 mm strong rope, lift limitation switch, drive shaft installed beneath head plate.
- **Rope deflection pulley** as well as double-sided installed slack rope switch.
- The **telescopic tubes** are made of 4 mm thick steel plates and installed on the loader head with solid chains.
- A appropriate **sensor** for the above-named bulk materials is installed on the outlet pipe outside the bulk material stream.
- **Material outlet** Ø 1200 mm made of 4 mm thick steel plates.
- **Dust skirt** Ø 1400 mm, made of exchangeable single segments of conveyor belt rubber, is installed at the end of the outlet socket.
- **Electrical design**: All limit switches and the sensor are connected in the terminal box beneath the loader head.

Details / Explanation

- After rust removal SA 2,5, a primer and top coat with hammer tone gray

Finish

JBM 350H

Scale Drawing
Overview

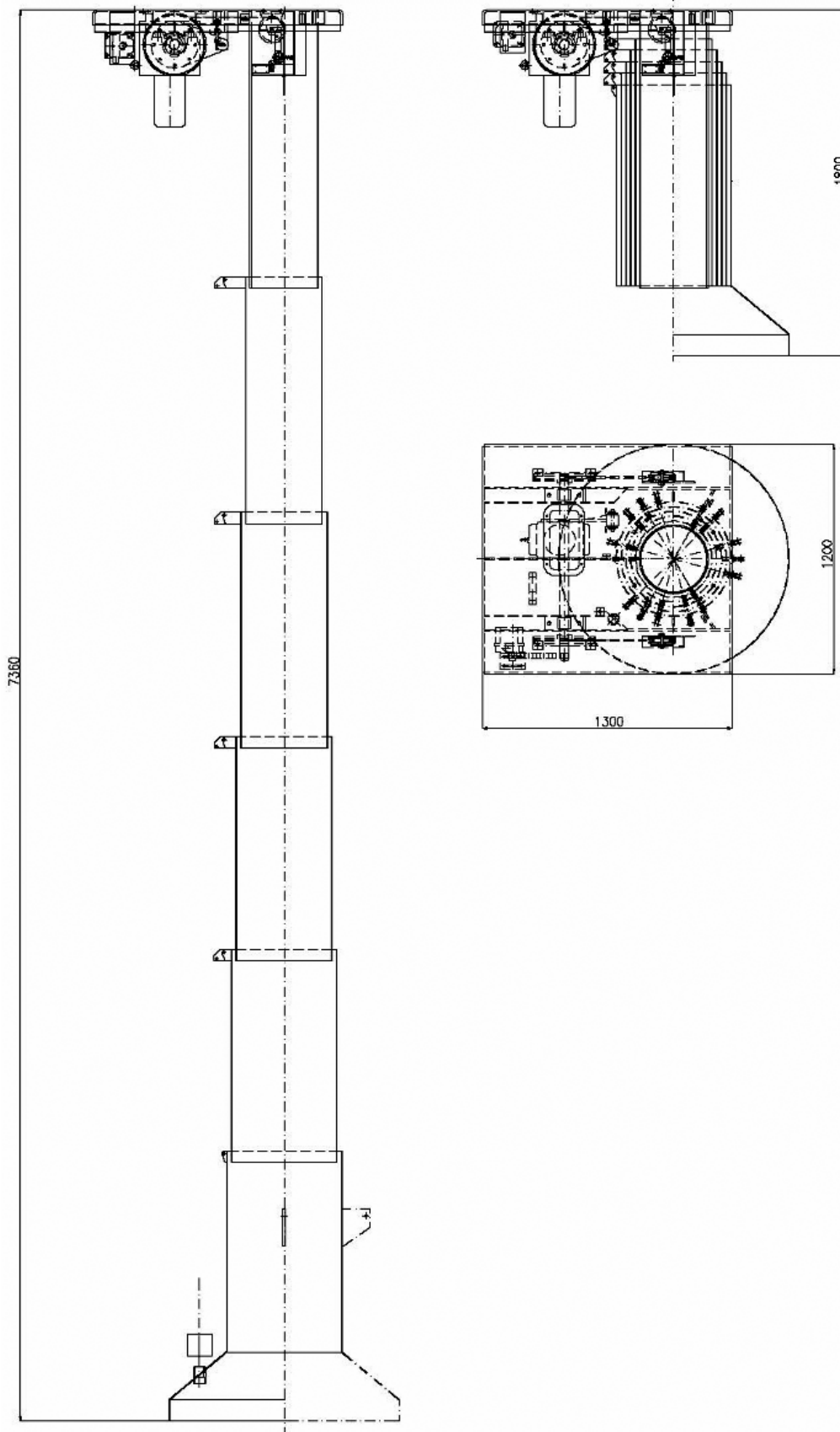

Technical Data JBM 350H

Type JBM 350H	350
Nominal diameter	350 mm
Loading capacity	290 m ³ / h
Construction height	1800 mm
Lift length	5000 mm
Weight	
Winch motor	1,1 kW , 400 V/50 Hz with stainless break
Sensor voltage	230 V/50 Hz
Break voltage	230 V/50 Hz

Article Number

Type JBM 350H	Article number
	751 10 168

Other designs and constructions on request.

SHIP LOADER JBM 500



The loaders type JBM 500 are specific loaders for loading of dry, free flowing bulk materials onto ships.

Areas of Application

- Installation friendly, compact **loader head**, with air exhaust sockets (300 x 600 mm). Built-in lift winch, slack rope switch, lift limit switch, terminal box
- Replaceable, 120° rotatable inlet pipe made of steel 37-2 (10 mm wall thickness)
- Telescope pipes are made of 4 mm thick steel plates and installed on the loader head with stable chains.
- Height adjustable sensor, suitable for the above described bulk materials, installed outside of the material stream. The feeding pipe of the sensor is operated with a clip cable reel outside of the rubber bellows.
- The **rubber bellows** consists of highly abrasion proof neoprene Hypalon coated with polyester canvas and clip steel rings as well as double-sided reinforced shields.
- **Dust skirt** (diameter Ø 1400 mm), made of exchangeable single elements (590 x 600 mm) of conveyor belt rubber, is installed at the end of the outlet socket.
- **Electrical design**: All limit switches and the sensor are connected in the terminal box beneath the loader head.

Details / Explanation

After rust removal SA 2,5, a primer and top coat with hammer tone gray

Finish

JBM 500

**Scale Drawing
Overview**

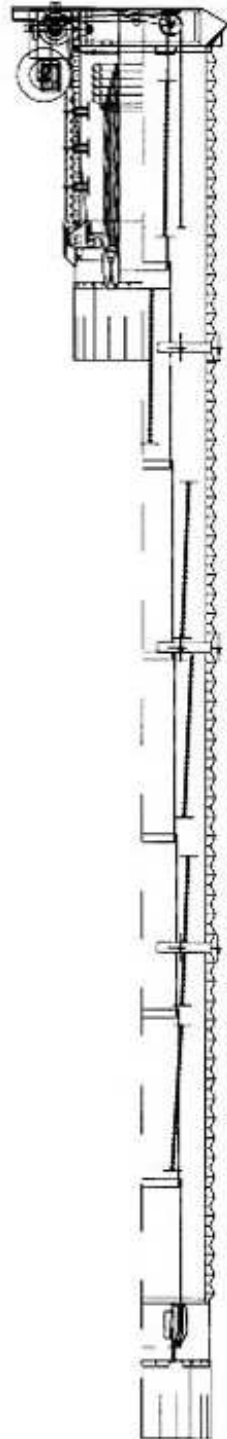

Scale Drawing Details

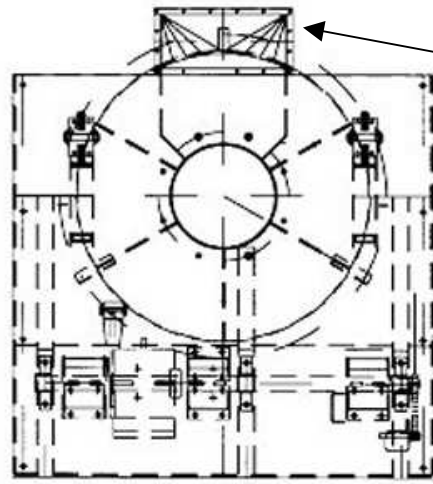

Dedusting socket

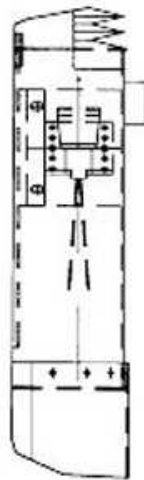

Side View
Filling level indicator

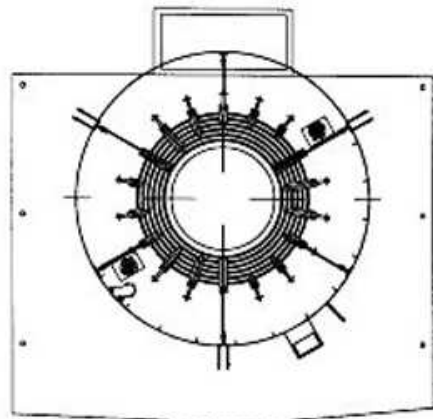

Technical Data JBM 500

Type JBM 500	500
Nominal diameter	500 mm
Loading capacity	480 m ³ / h
De-dustable air	approx. 10.000 m ³ / h
Construction height	2900 mm plus skirt 735 mm
Lift length	10 m
Weight	approx. 3900 kg
Winch motor	2,2 kW with brake, 400 V/50 Hz
Voltage brake	230 V/50 Hz
Voltage sensor	230 V/50 Hz

Article Number

Type JBM 500	Article number
	751 10 310

DOCKING STATION NW 200



The **docking station type NW 200** is used for loading small component bins with dry, free flowing bulk solids.

- Installation friendly, compact loader head with air exhaust socket (diameter Ø 100/108 mm), 2 pneumatic cylinders (diameter: Ø 100 mm), solenoid valve 230 V/AC, terminal box.
- Conical **inlet- and outlet-buckets** made of steel 37-2 (4 mm wall thickness).
- The **rubber bellows** consists of highly abrasion proof neoprene Hypalon coated with polyester canvas and clip steel rings.

- After rust removal SA 2,5, a primer and top coat with hammer tone gray.

Areas of Application

Details / Explanation

Finish

NW 200

Scale Drawing
Overview

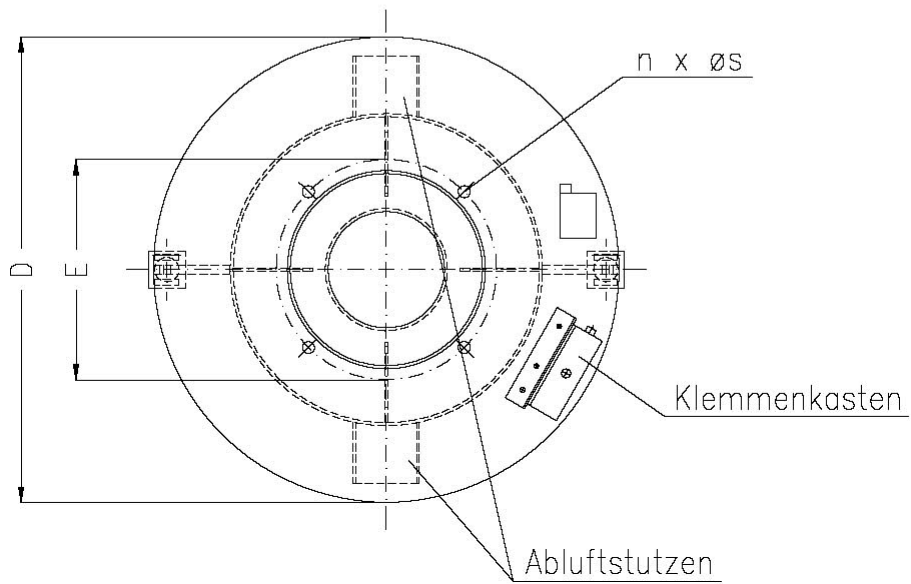
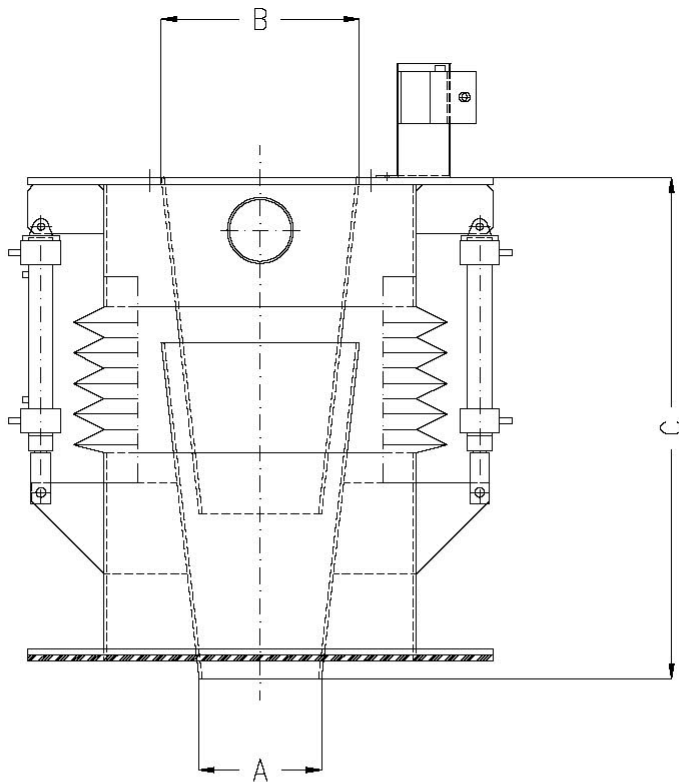

Technical Data NW 200

Type NW 200		200
Loading capacity		100 m ³ / h
Nominal diameter	A	200 mm
Inlet cross section	B	Ø 300 mm
Construction height	C	1395 mm
Lift length		440 mm
Weight		approx. 120 kg
Operating pressure		6 bar
Flange diameter	D	Ø 760 mm
Hole circle diameter	E	4 x M16 / hole circle diameter 360 mm

Article Number

Type NW 200	Article number
	751 10 302

Other nominal diameters and design on request!

LONGITUDINAL & CROSS TRAVERSING UNIT QLV 400



**Available as
Longitudinal
Traversing unit
longitudinal only**

The longitudinal & cross traverse unit **QLV 400** allows an exact positioning of telescopic loaders over the various hatches of silo vehicles and silo wagons.

Areas of Application

- Frame made of steel profiles.
- Funnel made of steel or in various stainless steel qualities.
- Installation of loader filter possible.
- Avoids damages on the loader and the vehicles.
- Low construction height allows installation in existing systems.
- Smooth loading from the control room.
- Fast movement of 400 mm in each direction.
- For hatches sized 300 x 300 mm, outlet Ø 300 mm.

Details / Explanation

- Material: Steel or stainless steel. Top coat hammer tone silver gray.

Finish

Dimensions / Technical Data

Inlet	ø 300 mm alternatively \square 300 mm
Outlet	ø 300 mm
Construction height	approx. 460 mm
Length	approx. 2100 mm
Width	approx. 1550 mm
Weight	approx. 520 kg
Moving range	2 x 200 mm

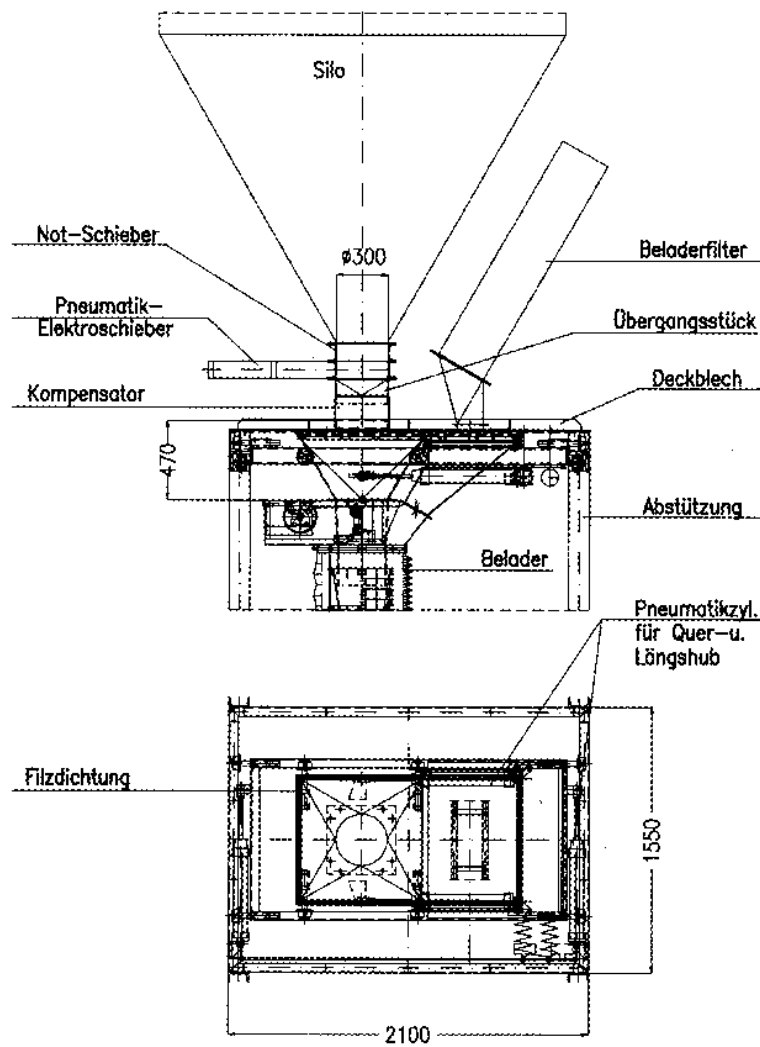

Article Number

Type QLV 400	Article number
Cross and Longitudinal traverse unit QLV 400 for fine positioning of the TELE-RONDO	755 10 001

LONGITUDINAL TRAVERSE UNIT LV 400

The longitudinal traverse unit **LV 400** allows an exact positioning of telescopic loaders over the various hatches of silo vehicles and silo wagons.

Areas of Application

-
- Frame made of steel profiles
- Funnel made of steel or in various stainless steel qualities.
- Installation of loader filter possible.
- Avoids damages on the loader and the vehicles.
- Compact size allows installation in existing systems.
- Smooth loading from the control room.

Details / Explanation

Material: Steel or stainless steel. Design St 37, Zinc-phosphate-grounding, approx. 40 µm, top coat with hammer tone silver gray, approx. 40 µm.

Finish

Dimensions / Technical Data

Inlet	ø 300 mm alternatively \square 300 mm
Outlet	ø 300 mm
Construction height	approx. 460 mm
Length	approx. 2100 mm
Width	approx. 1530 mm
Weight	approx. 380 kg
Moving range	2 x 200 mm

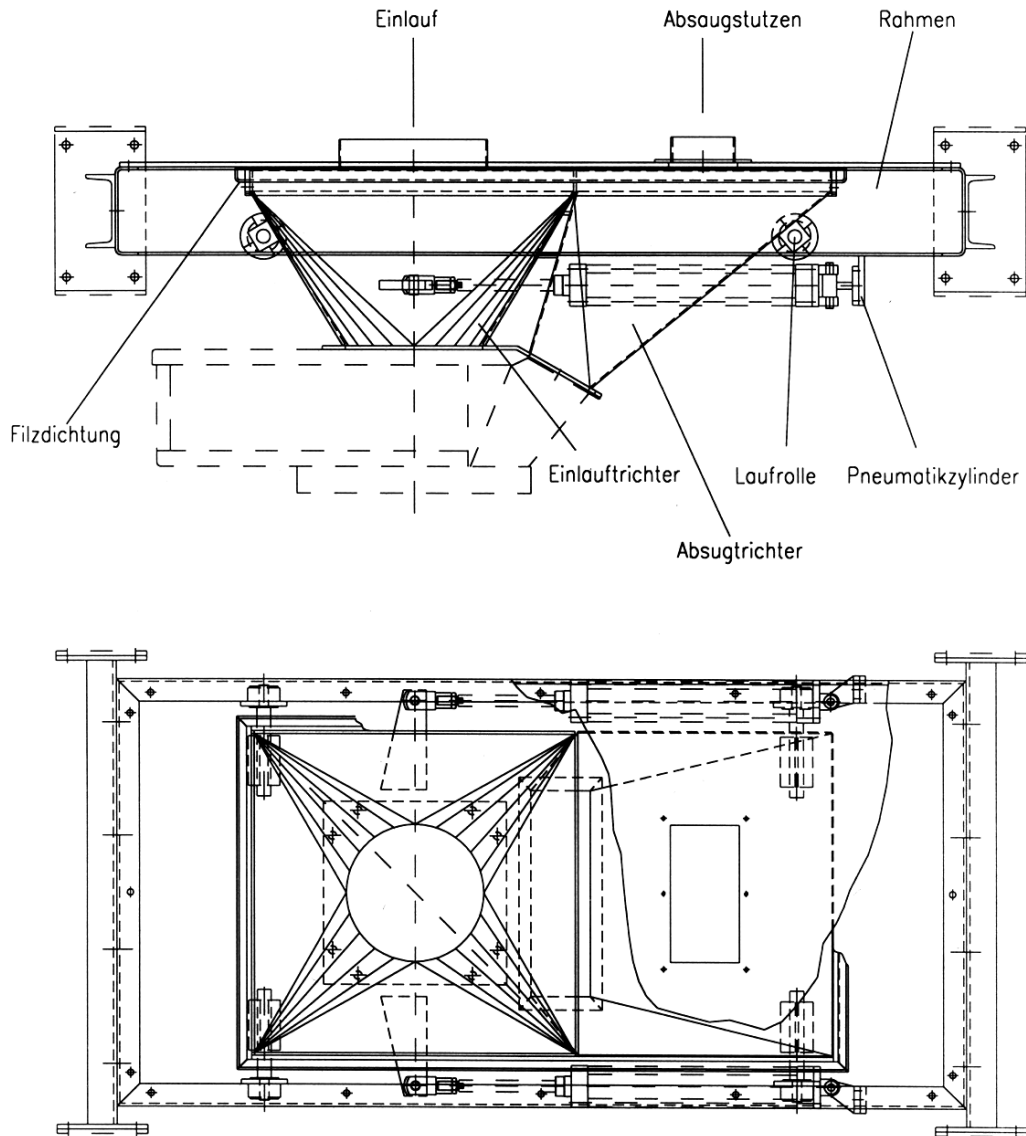

Article Number

Type LV 400	Article number
Longitudinal traverse unit LV 400 for fine positioning of the TELE-RONDO	755 10 003

FLOW-BOW - THE STRONG DEFLECTOR ELBOW

TO DEFLECT ABRASIVE BULK MATERIALS IN DENSE, PHASE MATERIAL CONVEYING PIPELINES



Optimal conduction of flow, wall thickness design and high-strength spheroidal cast iron, guarantee long durability and therefore low operating costs.

The Stanelle FLOW-BOW® elbow serves to deflect dry, non-clotting bulk materials with a highly wear-resistant system around corners in dense, phase material conveying pipelines. Areas of application are: from powdery and splintery materials to highly abrasive bulk materials, e.g. quartz sand, shotcrete, basalt chips, even animal body utilization. For applications in the plastics and foods industry special cast stainless steel (1.4408) models are available.

Areas of Application

- Stone-, Earth- and Mining industries
- Foundry technology
- Ceramics- and Glass industry
- Chemical- and food industry
- Animal utilization plants

The FLOW-BOW® is designed to build up a buffer layer of the abrasive material in the deflection elbow when conveying bulk materials. On this layer, the bulk material stream is deflected with very little wear. Because of the constantly changing buffer material cushion, the deflection area is still subject to abrasion. This area is therefore reinforced and the hard skin of the spheroidal cast iron provides additional abrasion protection. The material cushion is blown away completely by the final surge of the conveying stream. With soft bulk materials, such as for example marble, with a Morse hardness of less than 3, granule crumbling can occur in the cushion material.

Functionality

The graphic shows the wall thickness design and buffer material cushion in the FLOW-BOW®, through which an optimal wear protection is guaranteed.

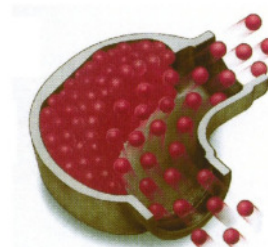

- Environmental due to less failures which could cause material loss
- Economical because of long service life
- Wear protection through optimal wall thickness design and material buffer cushion formation during dense phase conveying
- Wear resistant even with highly abrasive bulk materials
- FLOW-BOW® inlet and outlet sides can be varied and interchanged up to the DN 100 model; thus spare part costs are minimized if the worn flanges are replaced in time
- Simple installation and replacement due to optimal dimension and weight design

Details / Design

- Spheroidal or stainless steel cast iron (1.4408)
- Rust removal: SA 2,5
- Primer: 2K; 40µm
- Top coat: 2K; RAL 9006; 40µm

Finish

Dimensions for Flow Bow 90°, Flange/Flange-Connections

NW	40	50	65	80	100	125	150	175	200
PN	6	6	6	6 10	6 10	6 10	6 10	6 10	6 10
	10	10	10						
A	175	175	175	205	205	215	230	265	310
B	175	175	175	220	220	215	230	265	310
C	265	265	265	330	320	357	385	445	515
E	280	280	280	360	370	380	395	455	525
max. Width	150	150	150	230	230	220	240	320	390
D	130	140	160	200	210	250	285	315	340
	150	165	185		220				
K	100	110	130	150	170	200	225	255	280
	110	125	145	160	180	210	240	270	295
d ₂	14	14	14	18	18	18	23	23	23
	18	18	18		18				
n	4	4	4	4 8	4	8	8	8	8
	4	4	4		8				

All dimensions in mm, tolerances ± 2mm, flange dimensions ± 1mm

90° F/F

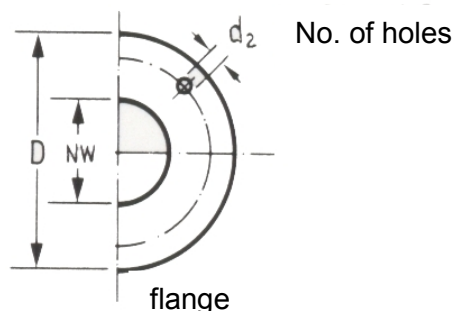
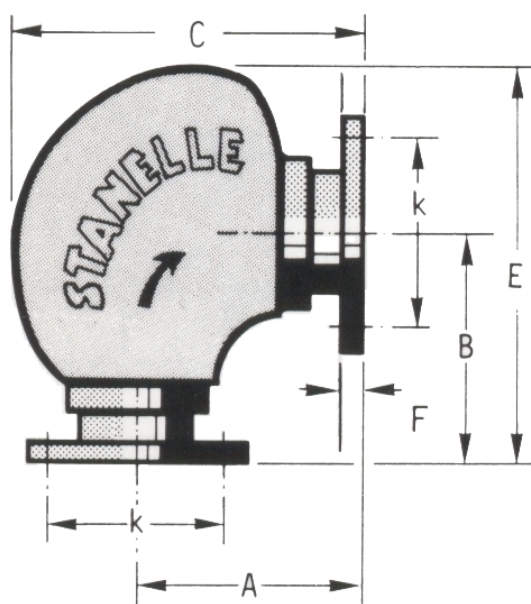

Dimensions Flow Bow 135°, Flange/Flange-Connections

NW	40	50	65	80	100	125	150	175	200
PN	6	6	6	6 / 10	6 / 10	6 / 10	6 / 10	6 / 10	6 / 10
	10	10	10						
A	123	123	123	197	197	183	190	198	205
B	295	295	295	352	352	442	460	477	495
C	250	255	260	272	350	300	320	325	365
	265	265	280						
E	340	345	365	370	425	510	530	550	590
	350	355	355						
max. Width	155	155	160	170	170	240	270	290	370
		165	185						
D	130	140	160	200	210	250	285	315	340
	150	165	185		220				
K	100	110	130	150	170	200	225	255	280
	110	125	145	160	180	210	240	270	295
d ₂	14	14	14	18	18	18	23	23	23
	18	18	18		18				
n	4	4	4	4 / 8	4	8	8	8	8
	4	4	4		8				

All dimensions in mm, tolerances ± 2mm, flange dimensions ± 1mm

135° F/F

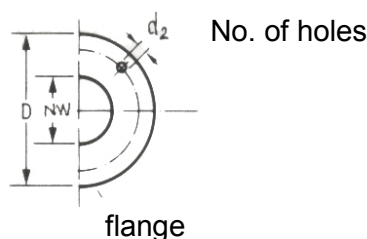
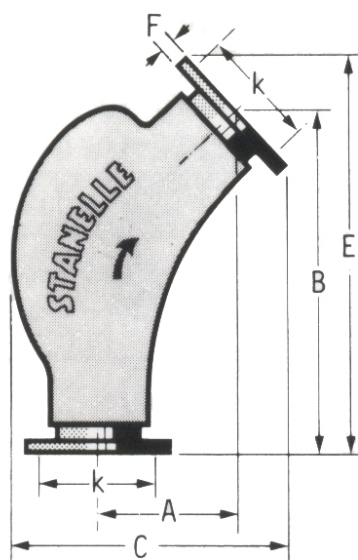

Combinations

Possible Combinations
90°

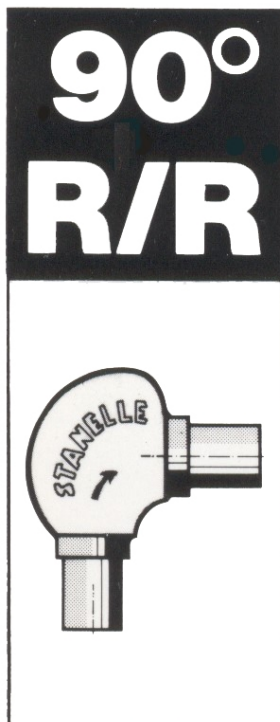

pipe / pipe

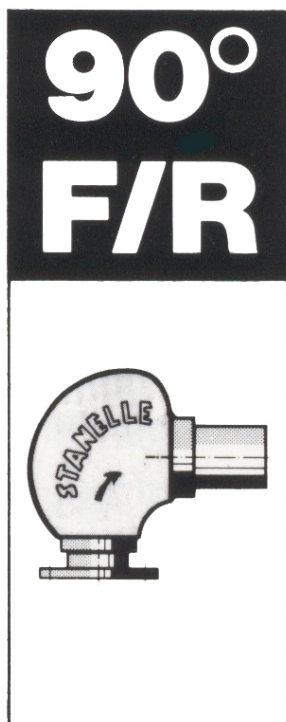

flange / pipe

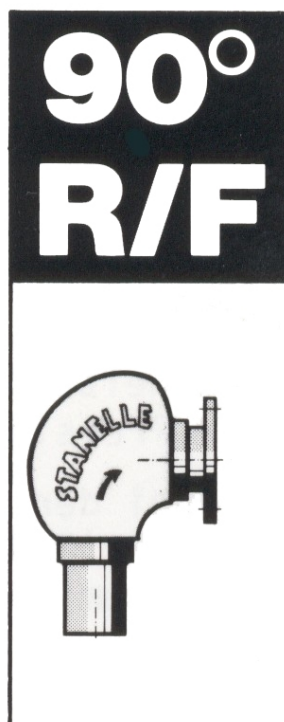

pipe / flange

90°

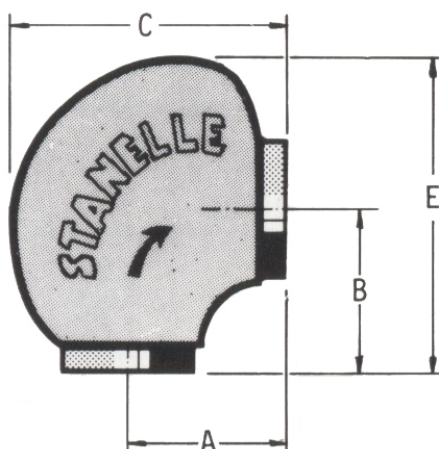

Thread	A	B	C	E
2 1/2"	120	120	210	225
4"	160	175	275	330

Housing 90°

All dimensions mm, tolerances ± 2mm

Combinations

Possible Combinations
135°



pipe / pipe



flange / pipe

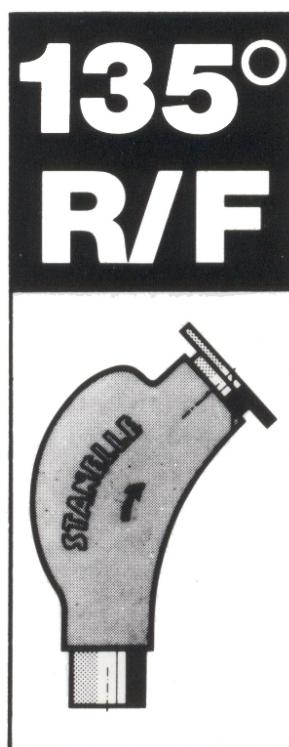

pipe / flange

135°

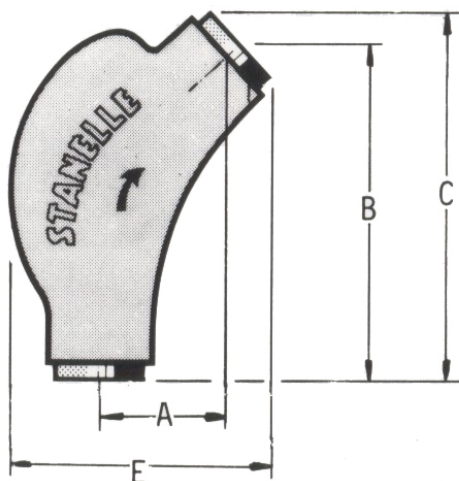

Thread	A	B	C	E
2 1/2"	85	200	235	198
4"	160	270	321	287

Housing 135°

All dimensions mm, tolerances ± 2mm

Dimensions Threaded Pipe

Thread	2 ½ "	4 "
NW	40	80
	50	100
	65	100
d1	48,3	88,9
	60,3	108
	76,1	114
S	2,6	3,2
	2,9	3,6
	2,9	3,6
L1	93	140
	87	115
	95	115
L2	70	90
	70	110
	70	110

Threaded Pipe

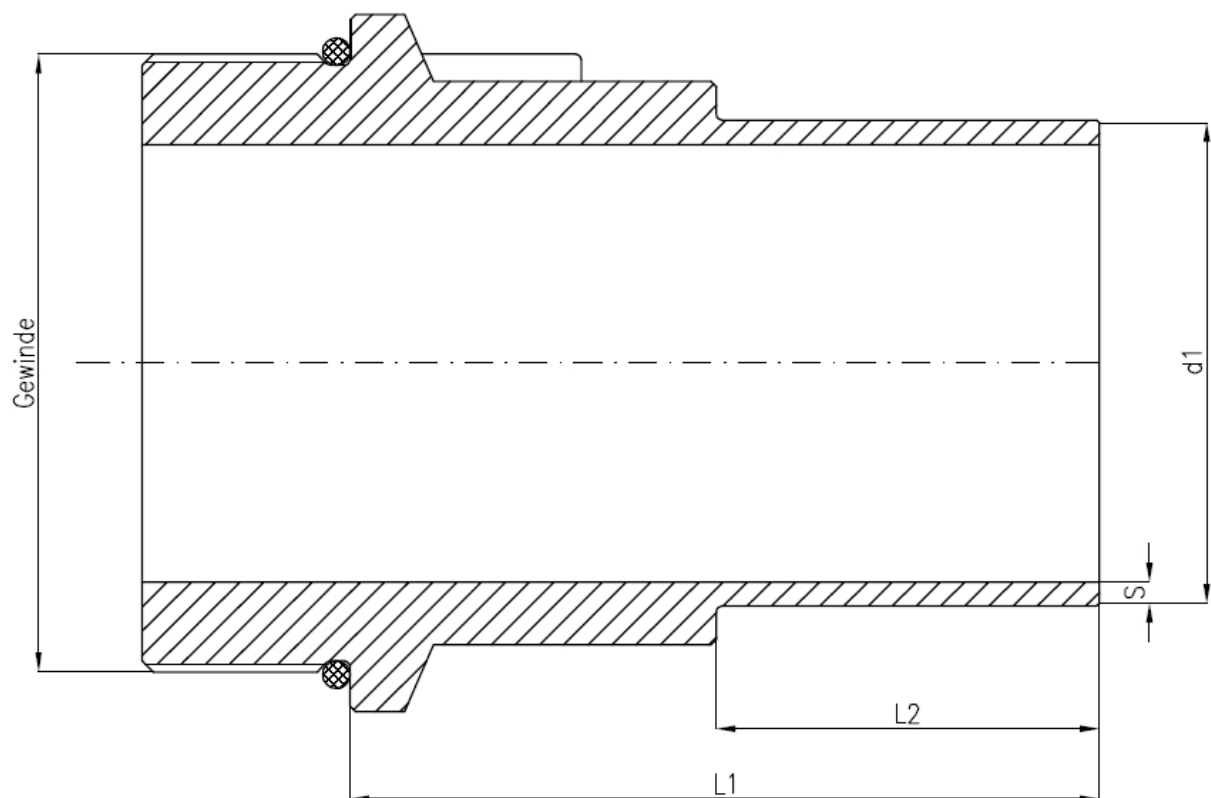

Dimensions Flange

Thread	2 ½ "		4 "	
NW	40		80	
	50		100	
	65			
L3	55		45	
	55		45	
	55			
PN	6	10	6	10
	6	10	6	10
	6	10	6	10
D	130	150	200	
	140	165	200	
	160	185		
K	100	110	150	160
	110	125	170	180
	130	145		
d2	14	18	18	
	14	18	18	
	14	18		
n	4		4	8
	4		4	8
	4			

All dimensions in mm, tolerances ± 2mm, flange dimensions ± 1mm

Flange

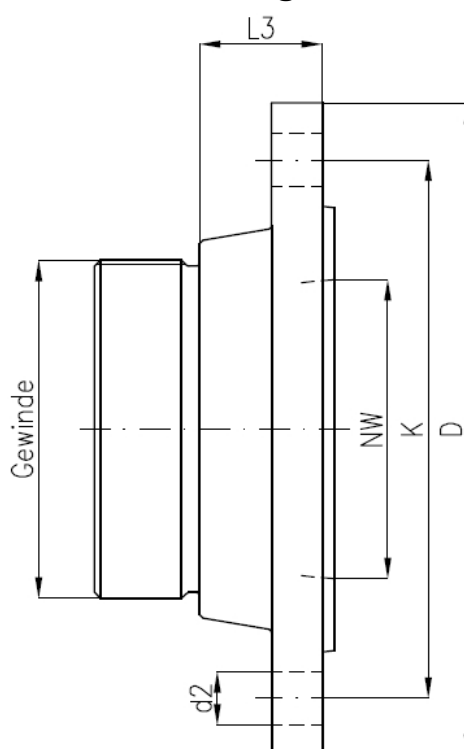

FILLING PIPES IN GALVANIZED DESIGN

Article Number

Nominal diameter 80:	Article Number
80/88,9 x 3,2	704 10 009
80/88,9 x 6,3	704 10 011

Nominal diameter 100:	Article Number
100/114,3 x 3,6	704 10 010
100/114,3 x 6,3	704 10 012

Nominal diameter 125	Article Number
125/133 x 4,0	704 10 039
125/133 x 6,3	704 10 040

Nominal diameter 150	Article Number
150/168,3 x 4,5	704 10 041
150/168,3 x 6,3	704 10 042

Nominal diameter 200	Article Number
200/219 x 4,5	704 10 044

Additional sizes tailored to your individual demands on request!

When placing an order, please define the bulk material you are conveying, e.g. cement, lime, sand, etc.

Notice



FILLING PIPE CLAMP IN GALVANIZED DESIGN

Article Number

Nominal Diameter 50:	Article Number
	704 10 090

Nominal Diameter 80:	Article Number
100 x 8,0 x 300	704 10 091

Nominal Diameter 100:	Article Number
100 x 8,0 x 300	704 10 056

Additional sizes tailored to your individual demands on request!

When placing an order, please define the bulk material you are conveying, e.g. cement, lime, sand, etc.

Notice



HALF ROUND BRACKET FOR FILLING PIPES IN GALVANIZED DESIGN

Article Number

Nominal diameter 50:	Article Number
	891 10 105

Nominal diameter 65	Article Number
	891 10 106

Nominal diameter 80:	Article Number
	891 10 004

Nominal diameter 100:	Article Number
	891 10 005

Nominal diameter 125	Article Number
	891 10 107

Nominal diameter 150	Article Number
	891 10 108

Nominal diameter 200	Article Number
	891 10 109

Additional sizes tailored to your individual demands on request!

When placing an order, please define the bulk material you are conveying, e.g. cement, lime, sand, etc.

Notice



FILLING PIPE COUPLINGS CONNEX

TO CONNECT AND SEAL PIPELINES EFFICIENTLY

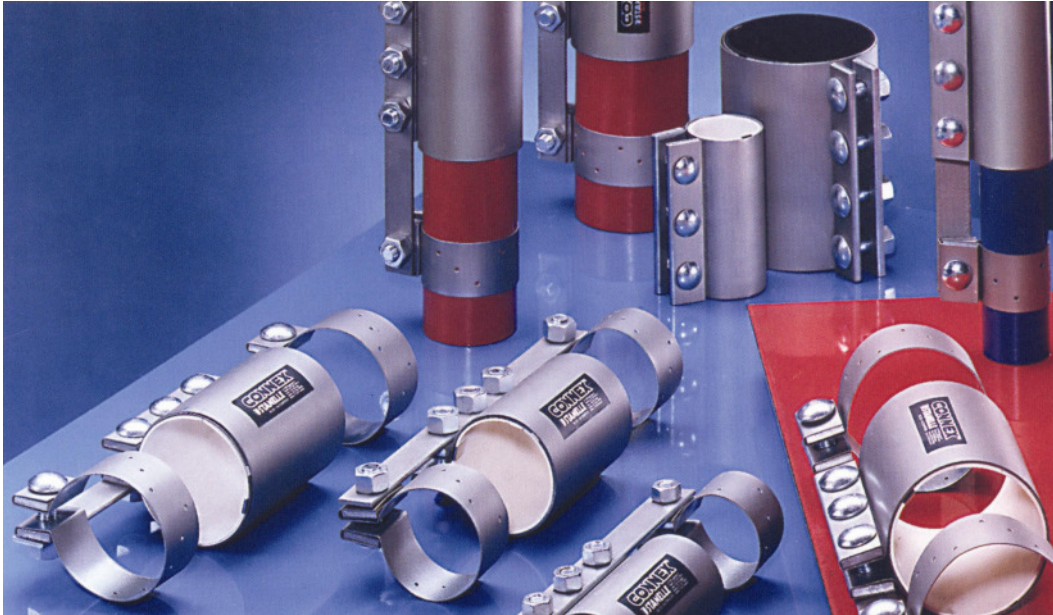

Notice



Normal couplings can be subsequently replaced with STANELLE CONNEX®-couplings

The **STANELLE-CONNEX® Pipe-Coupling System** provides the economically most favorable sealing and joining of conveyor pipelines. Pipelines for the pneumatic conveying of bulk materials are subject to heavy wear. Flanged joints, with their seals and off-centered construction, create turbulence and wear. The CONNEX® pipe couplings center the pipes offset- and vortex-free and the exterior gaskets seal the pipeline tightly. An inlaid stainless steel tape ensures potential equalization against the build-up of static electricity.

For extreme application conditions, e.g. high temperatures or heavy vibration, we provide pipe couplings with special extension arms which enforce the connection.

Areas of Application

The conveyor pipes are centered, fitted, spot-welded and sandpapered. The interlocking gasket of the CONNEX® coupling is laid around the pipe joint and pressed together to be pressure-tight with the screwed-on outer coupling casing. The interlocking rubber gaskets, with their different specifications, guarantee enduring gas- and dust-tight joints.

Functionality

- Perfectly fitted pipeline couplings
- Wear-reducing coupling
- Economical pipe coupling, since only spot welding is required

Details / Design

- Outside cladding: galvanized steel
- Sealing: Neoprene-stainless steel to avoid electrostatic charge.

Finish

Article Number

Outer pipe diameter in mm	CONNEX®-Coupling length in mm	Number of Screws	Article Number
38,1	100	2	702 10 007
48,3	100	2	702 10 008
50,8	100	3	702 10 009
54,0	100	2	702 10 010
60,3	150	3	702 10 003
70,0	150	3	702 10 011
76,1	150	3	702 10 012
82,5	150	3	702 10 013
88,9	150	3	702 10 014
88,9	200	4	702 10 015
95,0	150	3	702 10 016
95,0	200	4	702 10 017
101,6	150	3	702 10 018
101,6	200	4	702 10 019
108,0	150	3	702 10 020
108,0	200	4	702 10 021
114,3	150	3	702 10 022
114,3	200	4	702 10 026
127,0	150	3	702 10 023
133,0	150	3	702 10 024
133,0	200	4	702 10 025
139,7	150	3	702 10 027
152,4	150	3	702 10 28
159,0	150	3	702 10 029
168,3	150	3	702 10 030
168,3	200	4	702 10 031
193,7	150	3	702 10 034
203,2	150	3	702 10 032
219,1	200	4	702 10 057
254,0	200	4	702 10 033

Standard: without extension

Additional models, sizes and materials are available on request!

Notice



TWO-WAY VALVE ZR
TO DIVERT A CONVEYABLE MATERIAL STREAM INTO 2 PIPELINES IN
HIGH - OR LOW - PRESSURE CONVEYING SYSTEMS



Two-way valve
with pneumatic actuator



Two-way valve with electric drive
and emergency operation hand wheel

The two-way valve will be used for distribution of bulk products in two pipelines. However, it can be installed in a pneumatic low-pressure or in high pressure systems. The two-way valve can be used for all pneumatical conveyable solids, either in dust- or powder form. Exceptions are conveying products which incline to cake, stick or clump. Different sealing materials allows to convey products with temperatures up to 180° C without any problems.

Areas of Application

- Transfer tube consists of transfer tube housing, swivel arm with shut-off cone and the pneumatic rotary drive
- Sealing of the closed outlet with a sealing ring, which is pressed against a hardened ring
- Proximity switch for each end position for standard signal
- One 5/2-way impulse valve serves as control valve
- Electrical equipment can be supplied as required in any degree of protection and at any common voltage
- Also available in ATEX version

Details / Explanation

- Case: DN 50 - DN 150; in EN-GJS-400-15 (GGG 40)
DN 225; in EN-GJL-250 (GG 25)
DN 300 - DN 400; in EN-GJL-250 (GG 25)
on request all nominal diameters CIC coated
- Swivel arm: DN 50 - DN 150; in EN-GJL-250
DN 225; in EN-GJL-250
DN 250 - DN 400, in S235JR

Finish

- Cone tip material: DN 50 - DN 150; in C45
DN 225 - DN 400; in S235JR
- Gasket material: DN 50 - DN 150; in rubber, silicone oder viton
DN 225; in silicone
DN 250 - DN 400; in polyurethane

The transfer tube guarantees a perfect sealing of the shut down conveying line, so that material mixtures are excluded when conveying different materials through one system. The advantage of this design is that the sealing rings can be replaced without disassembly and with the shortest possible downtimes. When conveying of sticky and baking materials, a different switch construction must be selected.

Distinctive Characteristics

The transfer tube can also be equipped with electromotive/electropneumatic drive as well as with manual operation.

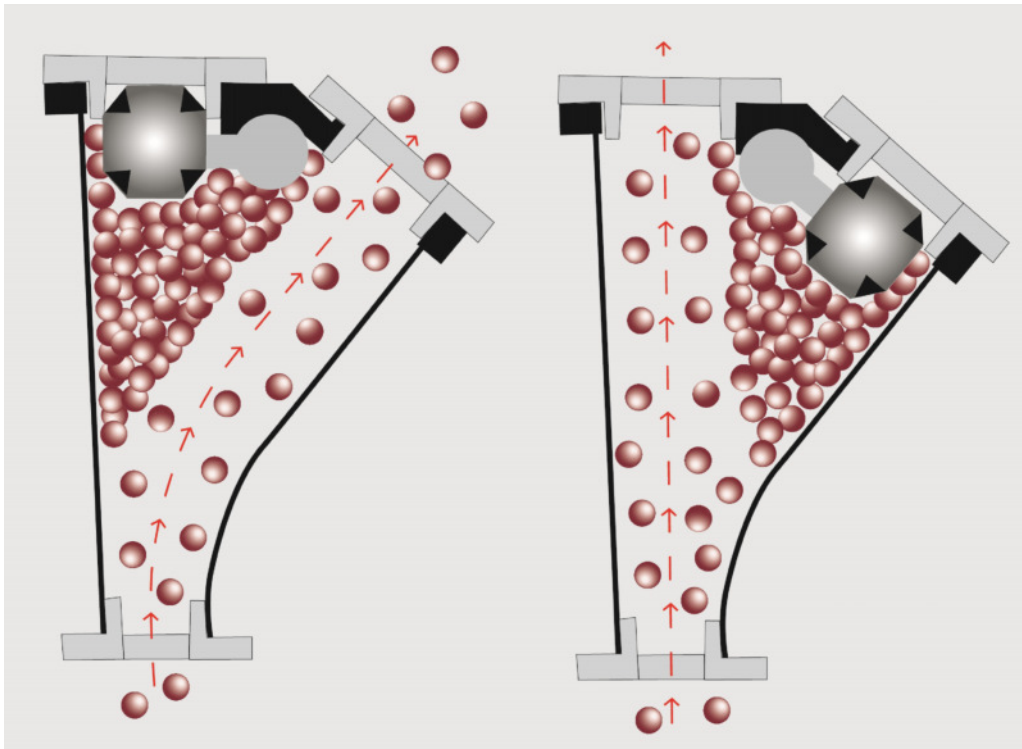

Picture: Grinding protection by a material cushion

Dimension table

DN	D	D1	L	A	N	O	S	d	P	M
50	165	125	520	245	89	210	18	4 x Ø18	326	335
65	185	145	520	245	89	210	18	4 x Ø18	326	335
80	200	160	520	245	89	240	18	8 x Ø18	326	335
100	220	180	580	255	95	260	20	8 x Ø18	326	335
125	250	210	715	320	115	290	22	8 x Ø18	326	335
150	285	240	800	360	130	315	22	8 x Ø22	326	335
175*	375	270	1050	400	147	464	25	8 x Ø22	337	350
200*	375	295	1050	400	147	464	25	8 x Ø22	337	350
225	375	325	980	400	147	464	25	12 x Ø22	337	350
250*	445	350	1200	501	183	522	30	12 x Ø22	353	350
300	445	400	1150	501	183	522	26	12 x Ø22	353	350
350*	565	460	1450	654	238	586	30	12 x Ø22	353	350
400	565	515	1420	654	238	586	32	16 x Ø26	353	350

* Intermediate sizes are realized via adapter flange/special insert flange

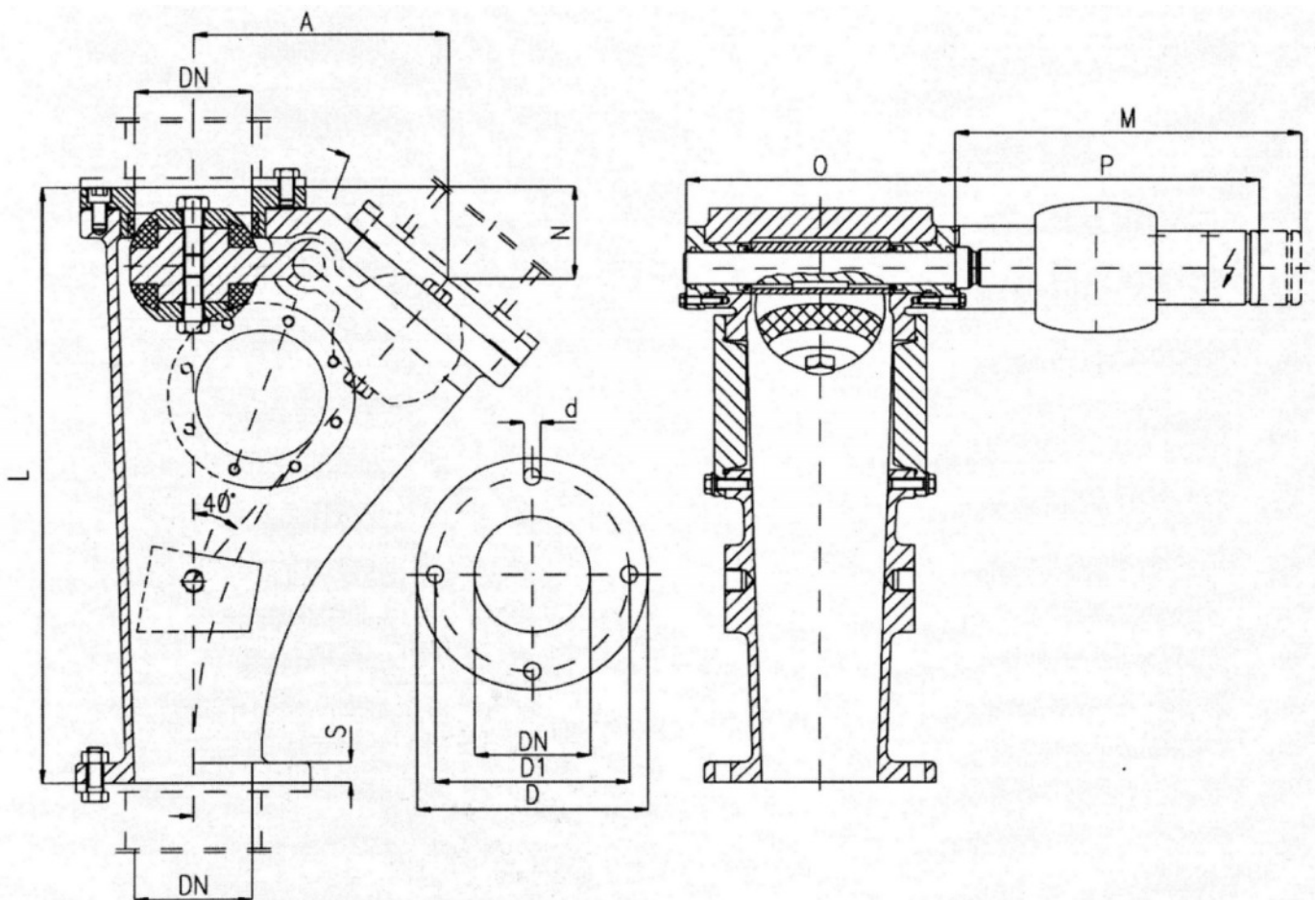

Technical data pipe switch

DN	50 - 400
Control pressure	approx. 5 bar
Operating pressure	max. 10 bar

Article number – pipe switch manual drive:

DN	up to 80°C	up to 120°C	up to 180°C
50	803 10 008	803 10 081	803 10 082
65	803 10 009	803 10 083	803 10 084
80	803 10 010	803 10 085	803 10 086
100	803 10 011	803 10 074	803 10 075
125	803 10 014	803 10 076	803 10 077
150	803 10 012	803 10 078	803 10 079
225	803 10 013	803 10 080	803 10 355

Other sizes available on request

Article number – pipe switch motor drive:

DN	up to 80°C	up to 120°C	up to 180°C
50	803 10 049	803 10 056	803 10 063
65	803 10 050	803 10 057	803 10 064
80	803 10 051	803 10 058	803 10 065
100	803 10 052	803 10 059	803 10 066
125	803 10 053	803 10 060	803 10 067
150	803 10 054	803 10 061	803 10 068
175	803 10 340	803 10 346	803 10 352
200	803 10 341	803 10 347	803 10 353
225	803 10 055	803 10 062	803 10 354
250	803 10 342	on request	on request
300	803 10 343	on request	on request
350	803 10 344	on request	on request
400	803 10 345	on request	on request

Article number – pipe switch pneumatic drive:

DN	up to 80°C 230V/AC valve	up to 80°C 24V/DC valve	up to 120°C 230V/DC valve	up to 120°C 24V/DC valve	up to 180°C 230V/AC valve	up to 180°C 24V/DC valve
50	803 10 007	803 10 029	803 10 015	803 10 036	803 10 022	803 10 043
65	803 10 006	803 10 030	803 10 016	803 10 037	803 10 024	803 10 044
80	803 10 005	803 10 031	803 10 017	803 10 038	803 10 025	803 10 045
100	803 10 001	803 10 032	803 10 018	803 10 039	803 10 026	803 10 046
125	803 10 002	803 10 033	803 10 019	803 10 040	803 10 027	803 10 047
150	803 10 003	803 10 034	803 10 020	803 10 041	803 10 028	803 10 048
175	803 10 300	803 10 306	803 10 311	803 10 317	803 10 323	803 10 330
200	803 10 301	803 10 307	803 10 312	803 10 318	803 10 324	803 10 331
225	803 10 004	803 10 035	803 10 021	803 10 042	803 10 325	803 10 332

Article number – pipe switch pneumatic drive:

DN	up to 80°C 230V/AC valve	up to 80°C 24V/DC valve
250	803 10 302	803 10 308
300	803 10 303	803 10 254
350	803 10 304	803 10 309
400	803 10 305	803 10 310

Spare parts list pipe switches

The spare part order numbers are structured as follows:

" instrument designation " " nominal size " - " number " - " material "

The nominal size and the materials used for your transfer tube can be found in chapter 2.0.

Example:

Sealing ring for ZR 100 transfer tube, with silicone sealing rings

Body for diverter valve ZR 65, material: GGG 40

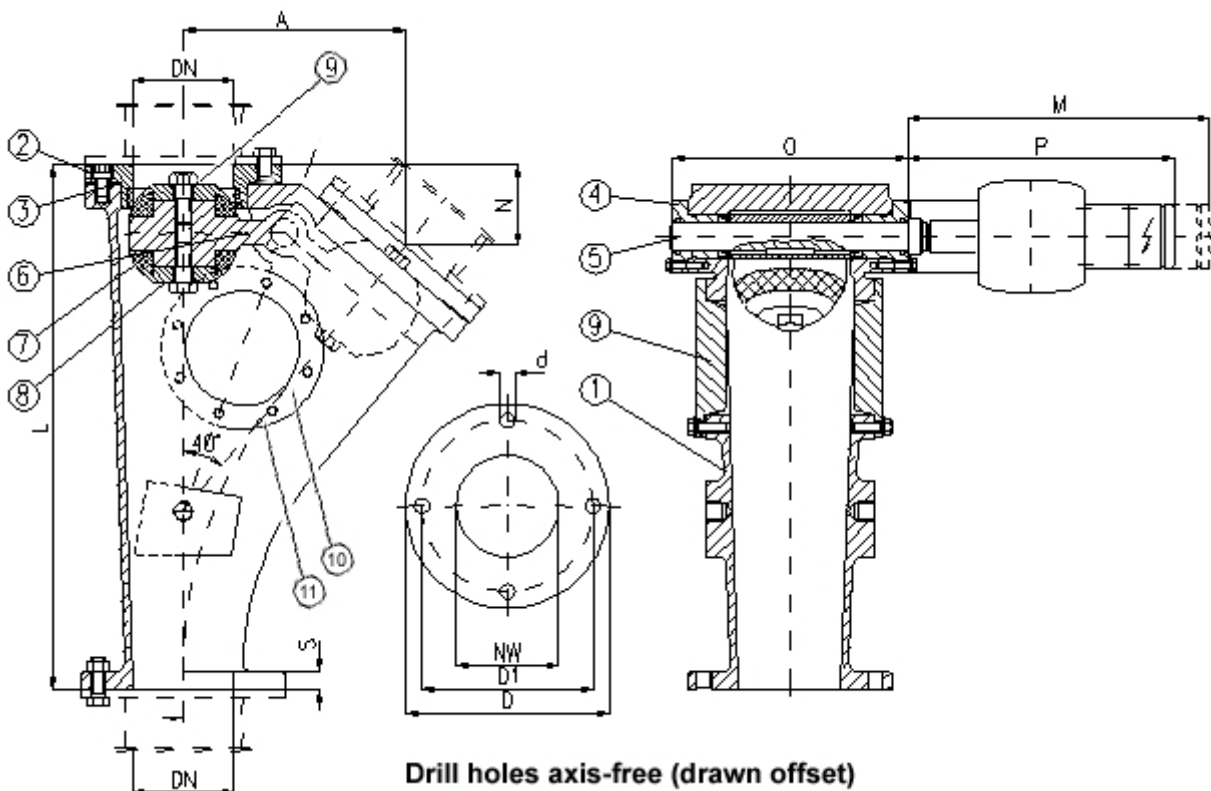

ZR 100 - 007 - silicone

ZR 65 - 001 – GGG 40



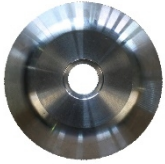

Manual drive

Position	Piece	Designation	Order code:	
1	1	Case	ZR... – 001 - ...	
2	2	Socket with inner ring	ZR... – 002 - ...	
3	2	Gasket for insert nozzle	ZR... – 003 - ...	
4	2	Guide bushes with gasket set to 120°C	ZR... – 004 - ...	
4	2	Guide bushing Steel plain bearing Viton O-ring for guide bush Steel < 180° C	ZR... – 004 - ...	
4a	1	Gasket set	ZR... – 004a - ...	
5	1	Shaft	ZR... – 005 - ...	
6	1	Swivel arm	ZR... – 006 - ...	

7	2	Gaskets with gasket set	ZR... – 007 - ...	
8	2	Cone tips	ZR... – 008 - ...	
9	2	Screw for cone tip	ZR... – 009 - ...	
9	2	Screw for cone tip hardened	ZR... – 009 - ...	

Electropneumatic actuator



Position	Piece	Designation	Order code:	
10	1	Mounting frame	ZR... – 010	
10	1	Handhole cover	ZR... – 010	
10	1	O-ring for hand hole cover	ZR... – 010	
11	1	Spacer sleeve	ZR... – 011	
12	1	Coupling element	ZR... – 012	

13	1	Slewing drive	ZR... – 013	
13a	1	5/2 solenoid valve type ...	ZR... – 013a	
13b	1	Limit switch	ZR... – 013b	

Electric motor drive

Position	Piece	Designation	Order code:	
14a	1	Flange (guide socket)	ZR... – 014a	
14b	1	Flange (on drive)	ZR... – 014b	
15	1	Spacer sleeve	ZR... – 015	
16	1	Coupling element	ZR... – 016	
17	1	Slewing drive	ZR... – 017	

Accessories / Spare parts

	Article number	
Parallel key for shaft	on request	
Seegring for shaft	on request	

PINCH VALVE SQV / FILLING PIPE END PIECE
Safety device for pneumatic filling of silos

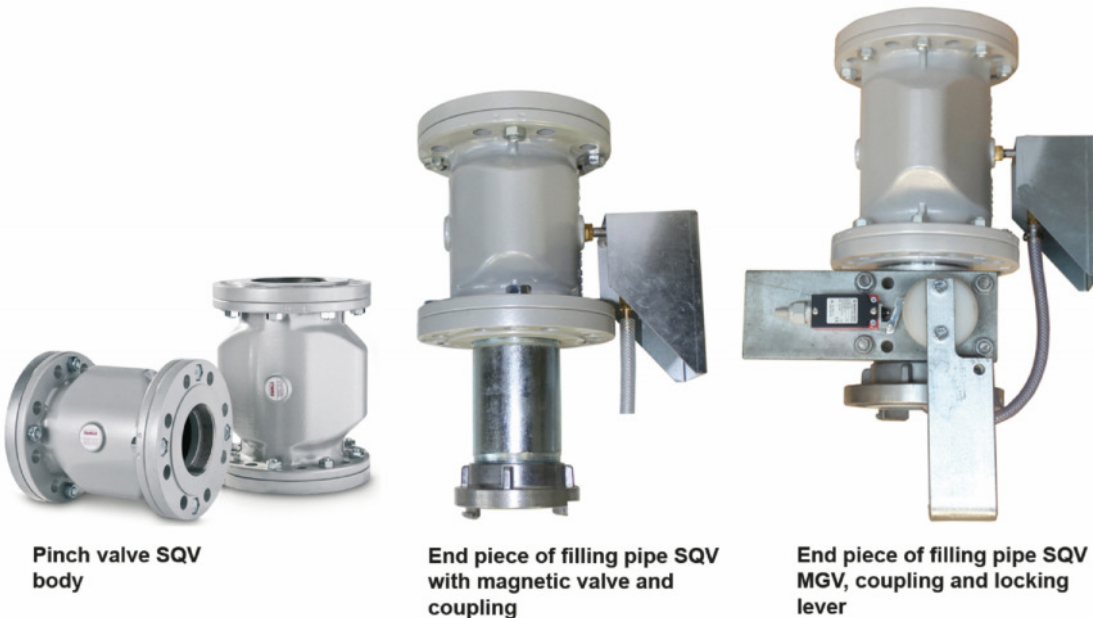

Pinch valve SQV
body

End piece of filling pipe SQV
with magnetic valve and
coupling

End piece of filling pipe SQV
MGV, coupling and locking
lever

Next to silos the pinch valves SQV are also used in several pneumatic conveying systems of the chemical and pharmaceutical industries, sand, concrete and cement industries, glass, ceramic and plastics industries as well as in dosage and weighing systems.

The basic valves are available from DN 40 to DN 200.

Areas of Application

The exchangeable sleeve is available in different elastomers for most diverse requirements. The housing and cone flanges of the valves are available in aluminium (standard), stainless steel or grey cast iron. As standard the sleeve is made of black natural rubber (NR), on request it is also available in white natural rubber (food-safe) and electrically conductive (ATEX).

Details / Explanation

The pinch valve closes by adding control air to the sleeve. By removing the control pressure the sleeve opens up to its full cross section. The design of the housing ensures proper closing of the sleeve and therefore safeguards the product flow to be shut-off absolutely tight as well as a maximum service life of the sleeve. Even larger solid particles are tightly covered and shut off.

Functionality

Advantages:

- free flow path without narrowings and jams
- no significant pressure loss
- free of dead space
- no clogging
- sleeve is easy to change
- leakage-free

Operating pressure:	max. 6 bar DN 40 to DN 100, max. 4 bar DN 125 to DN 200	Technical specifications
Control pressure:	approx. 2 bar higher than operating pressure	
Control air connection:	G 1/4"	
Connection:	Flange DIN 2576, PN 10	
Housing:	Aluminium, alternatively grey cast iron or stainless steel	
Hose sleeve:	Natural rubber NR, alternatively white natural rubber / electrically conductive	

Options / Special versions

Options

- Lockable locking lever with limit switch and padlock on site.
- Blind cover fixed coupling
- Pressure switch in control line
- Calming pipe 1m inlet
- ATEX
- MGV 24 V DC normally open / closed
- MGV 24 V AC normally open / closed

Dimensioned drawing basic version:

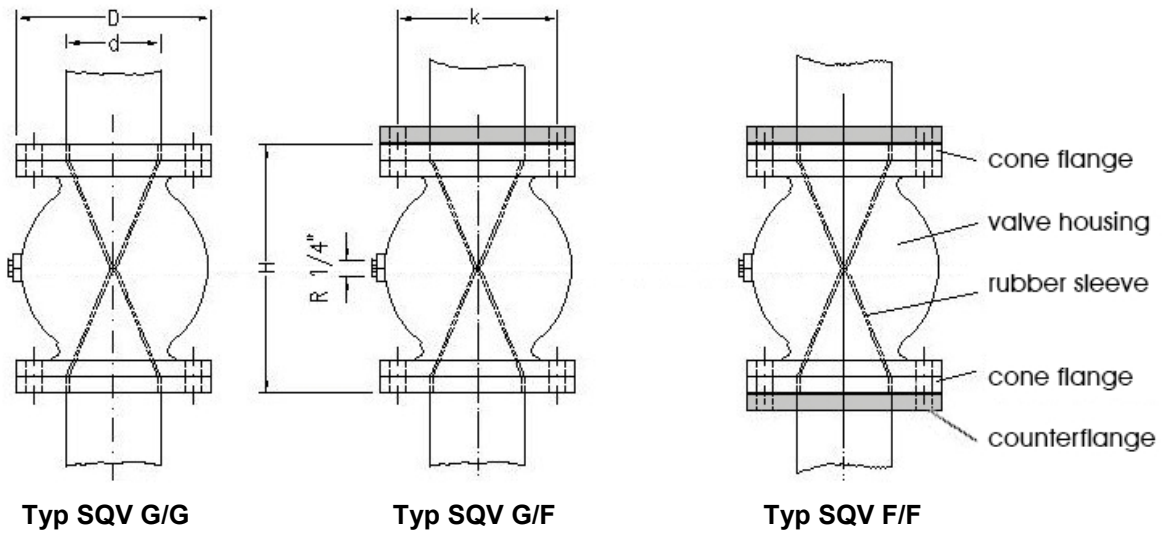

Typ G
(thread)

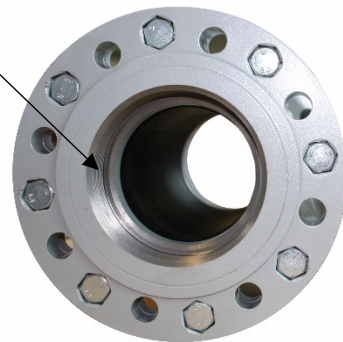

Typ F
(flange)

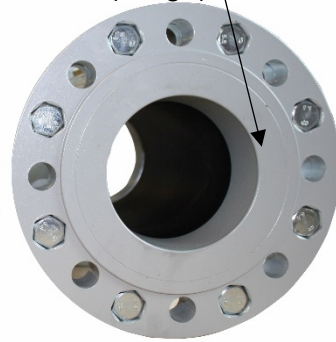

Measurement chart SQV – body

DN	Typ SQV G/G Art No.	weight [kg]Alu	Typ SQV G/F Art No.	weight [kg]Alu	Typ SQV F/F Art No.	weight [kg]Alu	K [m m]	D [mm]	D [mm]	H [mm]	Vol/l
40	801 10 021	3,1	801 10 160	3,3	801 10 059	5	110	150	1 ½"	155	0,3
50	801 10 150	3,9	801 10 161	4,3	801 10 089	5,5	125	165	2"	165	0,8
65	801 10 151	5,3	801 10 162	5,7	801 10 017	6	145	185	2 ½"	185	1,1
80	801 10 006	8	801 10 079	8,4	801 10 078	9	160	200	3"	225	2,2
100	801 10 007	11	801 10 008	11,5	801 10 077	11,9	180	220	4"	280	3,9
125	801 10 152	14,2	801 10 163	14,6	801 10 072	15,2	210	250	5"	350	4,5
150	801 10 153	21,1	801 10 124	21,6	801 10 080	22,7	240	285	6"	420	6,5
200	801 10 154	34,4	801 10 164	35,2	801 10 168	36,1	295	340	8"	560	16,1
Mounting flange: drilling diagram acc to. DIN 2576, PN 10											

**STANELLE end piece of filling pipe – STANDARD -
Further combinations / versions on request**

DN	End piece of filling pipe without locking lever G/F 230 V / AC open B or A coupling Art-No.	
80	801 10 052	
100	801 10 058	
DN	End piece of filling pipe without locking lever G/F 24 V / DC open B or A coupling Art-No.	
80	801 10 050	
100	801 10 056	

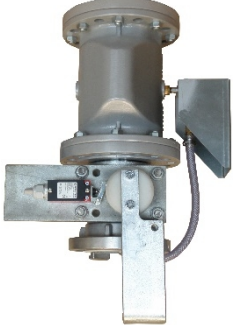
DN	End piece of filling pipe without locking lever G/F 230 V / AC open B or A- coupling Art No.	
80	801 10 099	
100	801 10 092	
DN	End piece of filling pipe without locking lever G/F 24 V / DC open B or A- coupling Art No.	
80	801 10 102	
100	801 10 094	

Equipment / Spare Parts

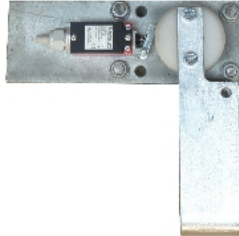
DN	Locking lever filling pipe with limit switch mechanical + cams Art-No.	
50	801 10 172	
65	801 10 171	
80	801 10 014	
100	801 10 012	
125	801 10 170	
150	801 10 013	

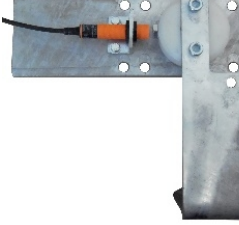
DN	Locking lever filling pipe / limit switch contact-free Art-No.	
50	on request	
65	on request	
80	801 10 014 - 01	
100	801 10 012 - 01	
125	on request	
150	on request	

DN	cover plate for solenoid valve Art-No.	
all	801 10 005	

	Art Nr.	Solenoid valve 24 V DC / 230 V AC 50Hz normally Closed NC	Solenoid valve 24 V DC / 230 V AC 50Hz Normally Open NO	
24V DC	881 10 024		X	
24V DC	881 10 036	X		
230V AC	881 10 035	X		
230V AC	881 10 005		X	

DN	Limit switch mechanical Art-No.	Standard	ATEX Zone 21/1
all	Standard 881 10 018		
	ATEX Zone 21/1 881 10 018 - 01		

DN	Cams for mechanical limit switch Art-No.	
all	801 10 107	

DN	Contact-free limit switch *1 24 V / DC Art No.	
all	881 10 270	

DN	Cams for contact-free limit switch *1 Art No.	
all	801 10 107 - 01	

*1 Applicable for customer's control or special execution Stanelle ÜFS

DN	Sleeve NR Art No.	
40	801 10 084	Operating temperature -10°C bis +80°C 
50	801 10 022-50	
65	801 10 022-65	
80	801 10 002	
100	801 10 001	
125	801 10 081	
150	801 10 082	
200	801 10 083	

DN	Cone flange with thread Art No.	
50	801 10 180	
65	801 10 181	
80	801 10 003	
100	801 10 018	
125	801 10 112	

Cone flange
with thread



DN	Cone flange without thread Art No.	
50	801 10 138	
65	801 10 129	
80	801 10 087	
100	801 10 086	
125	801 10 113	

Cone flange
without thread



DN	Fixed coupling IG nach DIN ISO 228 Art No.	
50	C-Kupplung 2" IG	871 10 027
65	C-Kupplung 2 1/2" IG	871 10 076
80	B-Kupplung 3" IG	871 10 003
100	A-Kupplung 4" IG	871 10 043
125	Kupplung 5" IG	871 10 074
150	Kupplung 6" IG	871 10 078





DN	Fixed coupling with blind cover Art No.	
50	on request	
65	on request	
80	801 10 011 (stainless steel)	
80	871 10 010 (aluminium)	
100	801 10 060 (stainless steel)	
100	871 10 033 (aluminium)	
125	on request	
150	on request	



DN	Pressure switch for control line Art No.	
all	732 10 018 - 01	

DN	Air hose Art No.	
all	801 10 085	

DN	Double nipples (only for versions G/G, G/F) Art No.	
50	on request	
65	on request	
80	891 10 002	
100	891 10 008	
125	on request	
150	on request	

DN	Single nipple with flange Art No.	
all	on request	

DN	Calming pipe 1m Art No.	
all	on request	

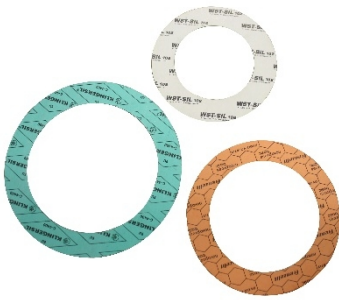
DN	Klingerit gaskets PN10 with bolts and nuts Art No.	
50	on request	
65	891 10 158	
80	891 10 117	
100	891 10 118	
125	891 10 156	
150	on request	

DN	Assembly paste appr. for easy exchange of rubber sleeve Art No.	
all	801 10 127	

**ADDITIONAL NOZZLES
FOR OPTIMIZING OF PNEUMATIC CONVEYING SYSTEMS
BY-PASS FOR BLOW THROUGH AND VERTICAL FLOW ROTARY VALVES**

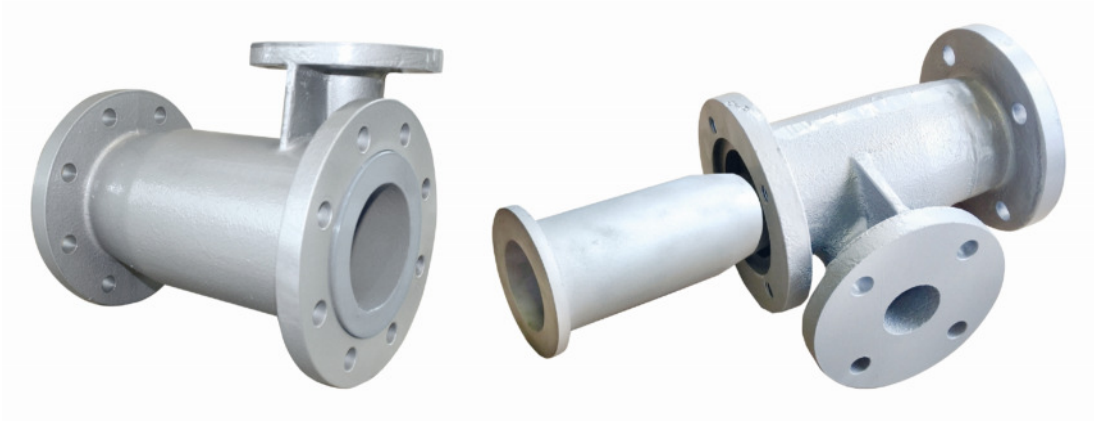

The additional nozzle ZD has three application areas or installation variants:

- A. The additional nozzle is installed in conveying lines of high-pressure conveying systems, mainly behind the special hose valve SP or outlet flap of the pressure conveying vessel. Conveying gas will be fluid into the conveyingline addiditonally.

**Areas of
Application**



**Picture:
Additional air supply to the outlet floor -
ZD directly after the outlet**

- B. The additional nozzle is installed in the conveying line - often in the middle or at the beginning of the entire section - in order to optimise long conveying lines with auxiliary air / conveying gas. In the case of long conveying distances, segregation of solids and conveying gas often occurs during dense phase / plug conveying. A partial quantity of conveying gas is introduced via the auxiliary nozzle to compensate for the gas shortage. A special delivery line additional nozzle insert is used here to prevent the material flow or the delivery rate from being affected by the standard to tie up the auxiliary nozzle insert.

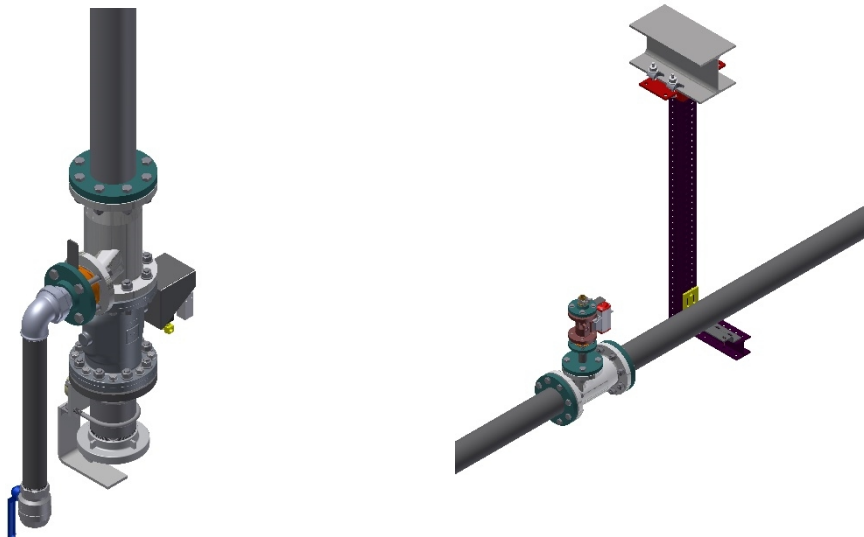

Picture:
Additional air supply Application -
ZD directly at the supply point

Picture:
Additional air Filling line centre -
ZD in the centre of the line

Areas of
Application

- C. The additional nozzle is used to reduce the leakage air at a cellular wheel - vertical fall or blow-through airlock (injector principle) Bypass solution.

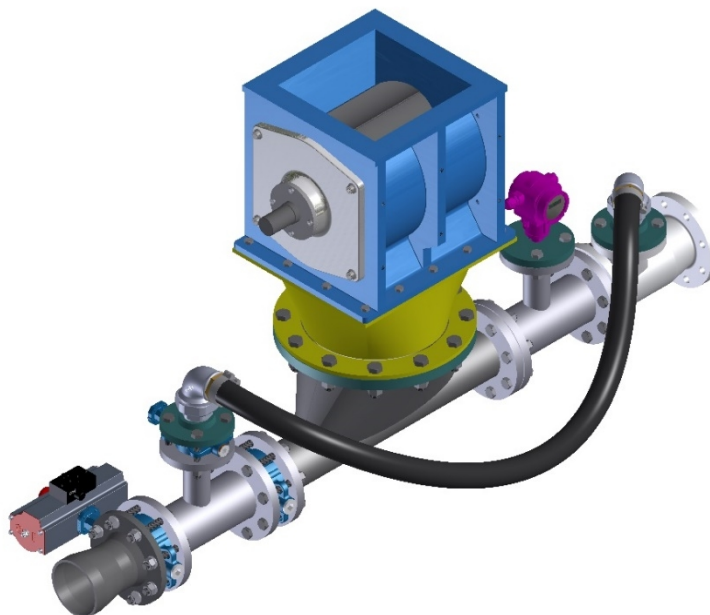

Picture:
Bypass application - ZD at the end of the feeding shoe

The dust-gas mixture is varied by changing the orifice insert.

- The additional nozzle ZD consists of the nozzle housing, the orifice insert including a seal for the nozzle insert.
- The insert can be drilled up to a specified diameter as required or a special cylindrical insert is available for filling lines.
- Due to the tangential arrangement of the air nozzle, the air inlet is largely vortex-free.

Details / Design

- Case: Grey cast iron EN-GJL-200 or
 Version DN 80 in spheroidal cast iron EN-GJS-400-15
 or as welded steel or stainless steel construction

- Rust removal: SA 2,5
- Primer: 2K; 40µm
- Top coat: 2K; RAL 9006; 40µm

Finish

- Shut-off cone: EN-GJL-200, welded steel or stainless steel construction
- Inner cone: not painted

Dimension table additional nozzle

DN1	A	B	C	D1	D2	d1	d2	d3	E
50	65	115	30	165	115	4 x M 16	4 x Ø 18	4 x Ø 14	96
65	85	125	42,5	185	165	4 x M 16	4 x Ø 18	4 x Ø 18	120
80	85	130	42,5	200	165	8 x M 16	8 x Ø 18	4 x Ø 18	130
0	75	150	55	220	165	8 x Ø 18	8 x Ø 18	4 x Ø 18	145
125	75	170	68	250	165	8 x M 16	8 x Ø 18	4 x Ø 18	185
150	100	190	75	285	185	8 x Ø 23	8 x Ø 23	4 x Ø 18	210
200	125	200	100	340	200	8 x Ø 23	8 x Ø 23	8 x Ø 18	250

K1	K2	DN2	DN3	L1	L2	S1	S2
125	85	37	25	200	195	18	16
145	125	45	50	250	245	18	16
160	125	50	50	300	295	22	18
180	125	50	50	300	295	22	18
210	125	90	50	300	295	22	18
240	145	100	65	300	295	22	18
295	160	125	80	400	397	24	18

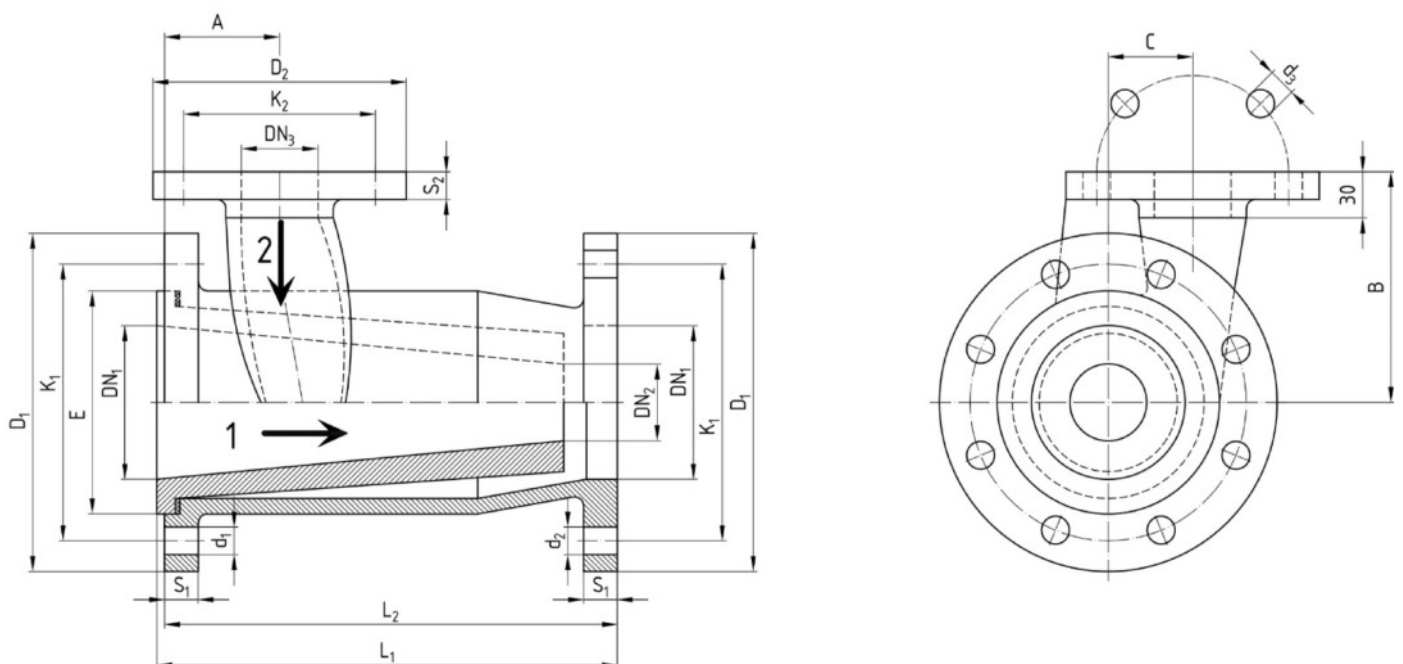

Technical data additional nozzle

	DN 50	DN 65	DN 80	DN 100	DN 125	DN 150	DN 200
Weight kg	12	20	25	31	38	52	80

Additional nozzle with standard insert directly at the high-pressure conveying system

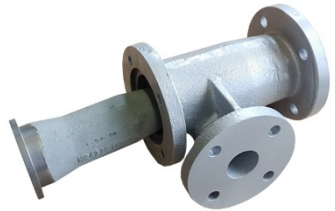
	Article number	
DN 50	707 10 001	
DN 65	707 10 002	
DN 80	722 10 003	
DN 100	707 10 004	
DN 125	707 10 005	
DN 150	707 10 006	
DN 200	707 10 016	

Additional nozzle with filling line insert for pipelines and directly after the rotary valve

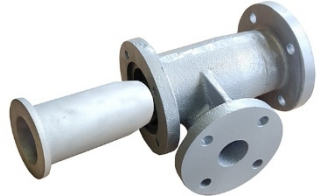
	Article number	
DN 50	707 10 007	
DN 65	707 10 008	
DN 80	722 10 009	
DN 100	707 10 010	
DN 125	707 10 011	
DN 150	707 10 012	
DN 200	707 10 017	

Spare parts

Additional nozzle housing

	Article number	
DN 50	45-026-GG	
DN 65	45-007-GG	
DN 80	45-010-GGG	
DN 100	45-001-GG	
DN 125	45-013-GG	
DN 150	45-042-GG	
DN 200	45-031-S235	

Conical insert for additional nozzle

	Article number	
DN 50	45-027-GG	
DN 65	45-008-GG	
DN 80	45-011-GGG	
DN 100	45-002-GG	
DN 125	45-014-GG	
DN 150	45-041-GG	
DN 200	45-032-GG	

Cylindrical insert for additional nozzle

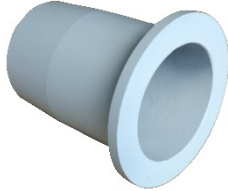
	Article number	
DN 50	Auf Anfrage	
DN 65	Auf Anfrage	
DN 80	Auf Anfrage	
DN 100/80	45-203	
DN 125/100	45-204	
DN 150/125	45-1017	
DN 150	Auf Anfrage	
DN 200	Auf Anfrage	

Flat gasket for use with additional nozzle

	Article number	
DN 50	45-100	
DN 65	45-101	
DN 80	45-102	
DN 100	45-103	
DN 125	45-104	
DN 150	45-105	
DN 200	45-106	

INSERT BOW FOR EASY CONNECTION TO SILOS

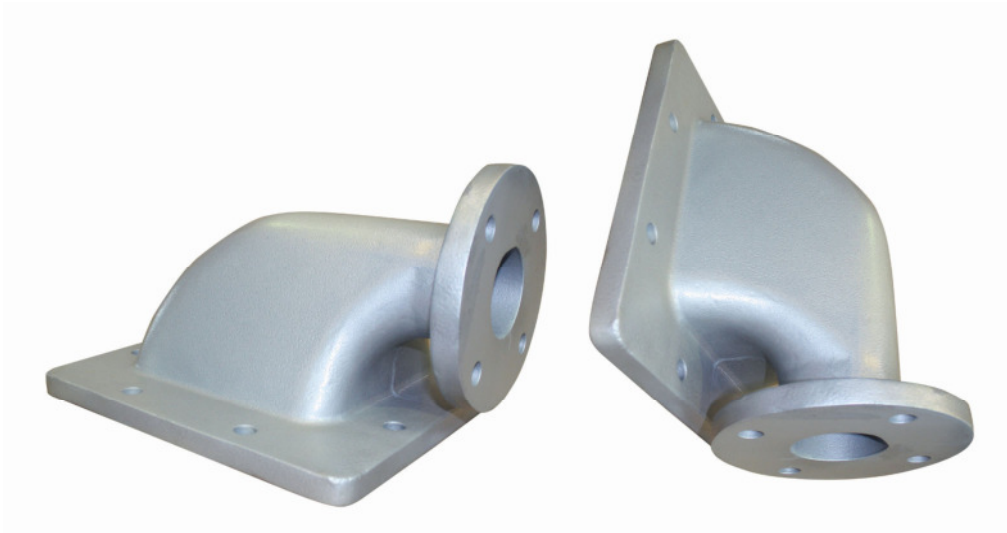

The gas-dust mixture is deflected at right angles through the silo inlet bend and introduced into the silo. Due to the space-saving design and use of the block flange, the conveying line can be guided close to the silo. This results in a favourable transport mass for assembled conveying lines. Weld-in or flanged flanges allow favourable installation options and trouble-free position adjustment during assembly. The design results in a favourable flow deflection of 90° and direct injection into a silo. Long service life is achieved through expanding design and optimum wall thickness design. A further advantage is that bulk materials are deflected more gently and without turbulence, which is necessary for soft materials and plastic granulate.

Areas of Application

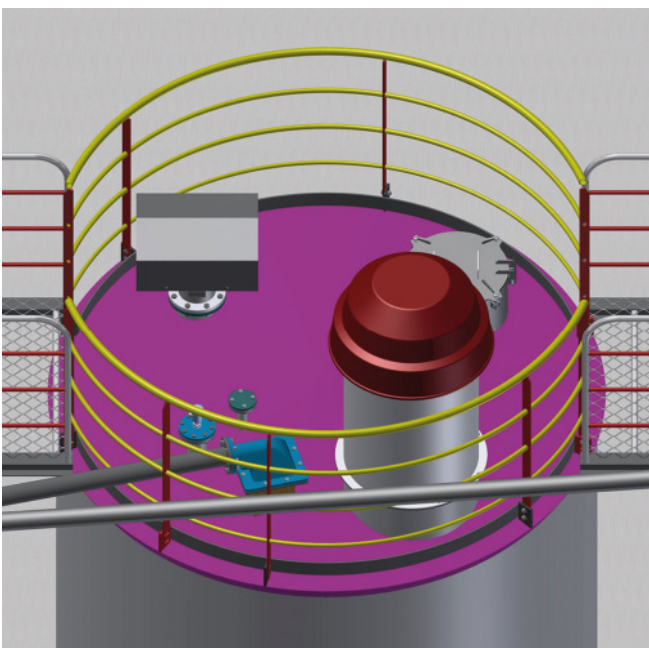

Picture:
Insert bow from the top

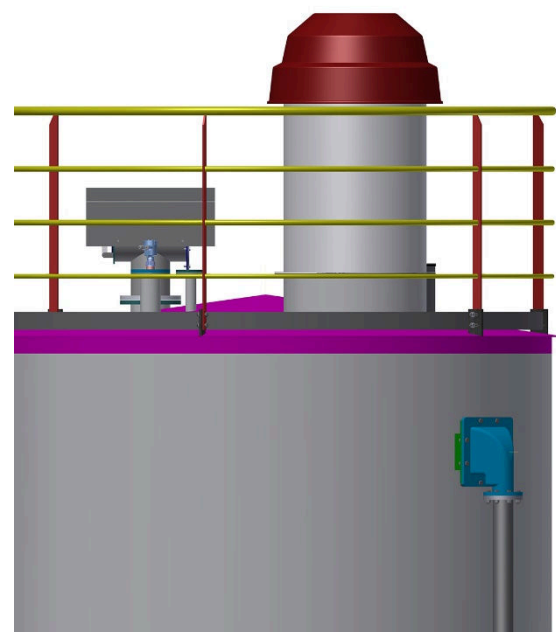

Picture:
Insert bow from the side

- Low wear during flight conveyance
- Gentle material deflection
- Very good flow properties due to expansion, already at the beginning of the deflection
- No clogging with coarse-grained bulk materials
- No vortex formation possible
- Case: Grey cast iron EN-GJL-200 or

Details / Design

- Rust removal: SA 2,5
- Primer: 2K; 40µm
- Top coat: 2K; RAL 9006; 40µm

Finish

Dimension table insert bow

DN/PN10	50	65	80	100	125	150
A	160	192		240	290	340
E	290	332		388	460	510
F	250	292		348	410	460
C	110	125		135	150	170
G	130			260		
H	20					
D	263	301		353	--	--
D1	219	273		323,9	--	--
S1	4,5	5,6		--	--	--
s2	30			40		
d1	18					
d2	M16					
Weight SEB kg	19	25	26	42	55	70

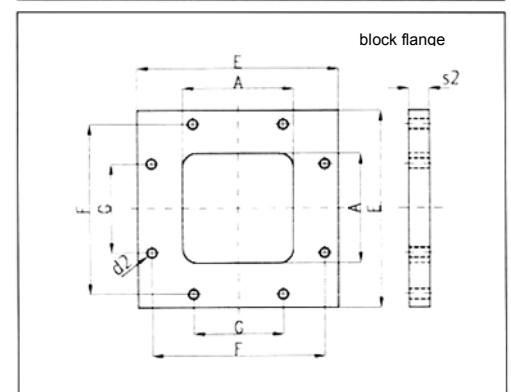
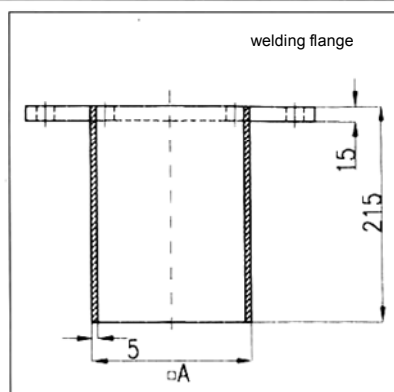
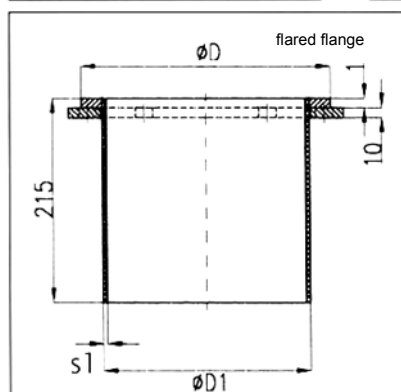
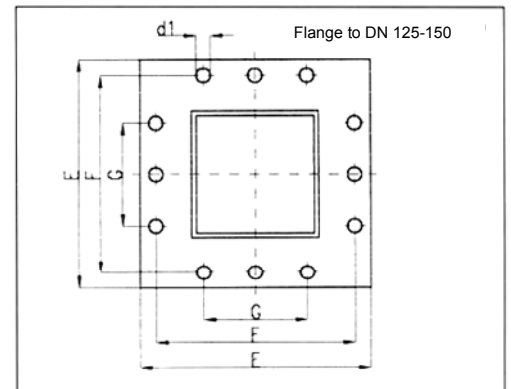
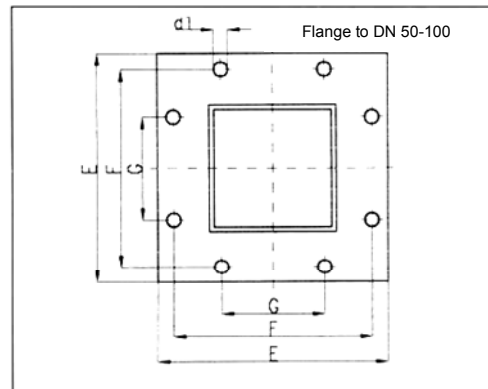
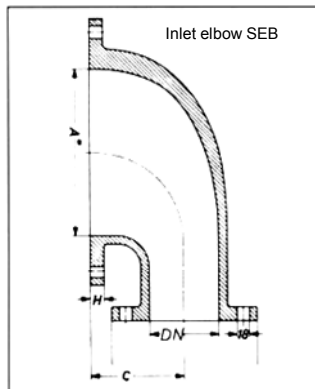

DN/PN10	Grey cast
	Article number
50	706 10 001
65	706 10 002
80	706 10 003
100	706 10 004
125	706 10 005
150	706 10 006

TUBULAR SCREW CONVEYOR

FOR HORIZONTAL AND RISING CONVEYING OF DRY BULK MATERIALS



Screw conveyors for horizontal and rising conveying (up to 45°) of dry, powdery to granular bulk materials. Standard tube diameter and a modular system for screw assembly guarantee quality and an optimal price-performance ratio

Areas of Application

- The basic gear motors are designed for the building industry. Two types of motors with three transmission ratios are available.
- 4-pole IEC standard motors from 2.2 to 22 kW provide a wide range of conveying capacities.
- The compact design, progressive helix pitch and especially the spring-loaded stuffing box seal are essential advantages for trouble-free operation.
- The standard gear unit is connected to the screw helix and the bearing units by a maintenance-friendly splined shaft connection and enables maximum flexibility in the planning, production, placement and assembly of the screw conveyors.
- Individual screw inlet and outlet designs using flanges, pipe beads or universal inlets for adjusting inclination and displacement angles complete the modular system and simplify installation.
- Optional Hardox spiral or, depending on the medium to be pumped, specially treated screw helix, enable optimum service life, even under extreme operating conditions.

Details / Explanation

- Rust removal: SA 2,5
- Primer: 2K; 40µm
- Top coat: 2K; 40µm; screw RAL 9006
- Drive and end bearing units RAL 5010
- other RAL colours on request

Finish

System configuration:

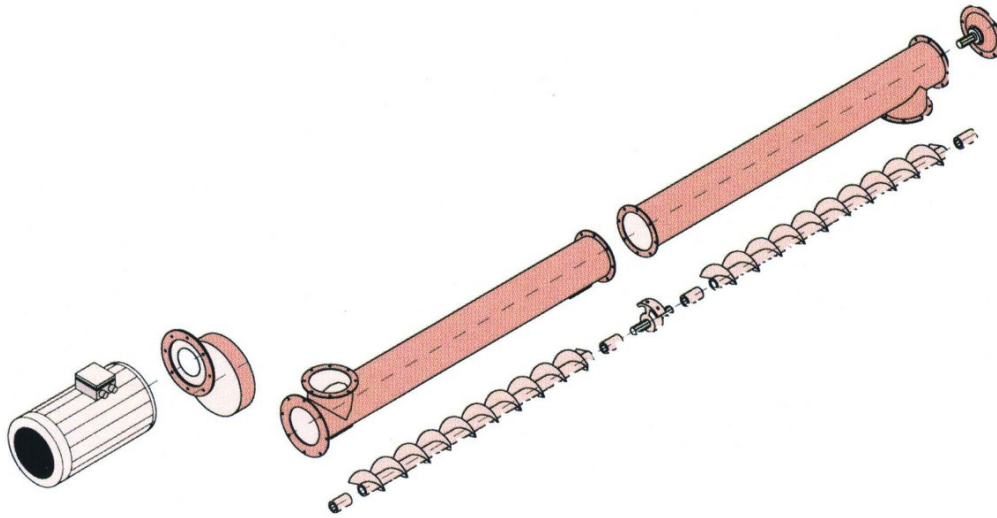

In the case of abrasive media, Hardox coils or coils armoured by hardfacing can be used.

Construction of the tubular screw conveyor

Notice



Universal inlet:

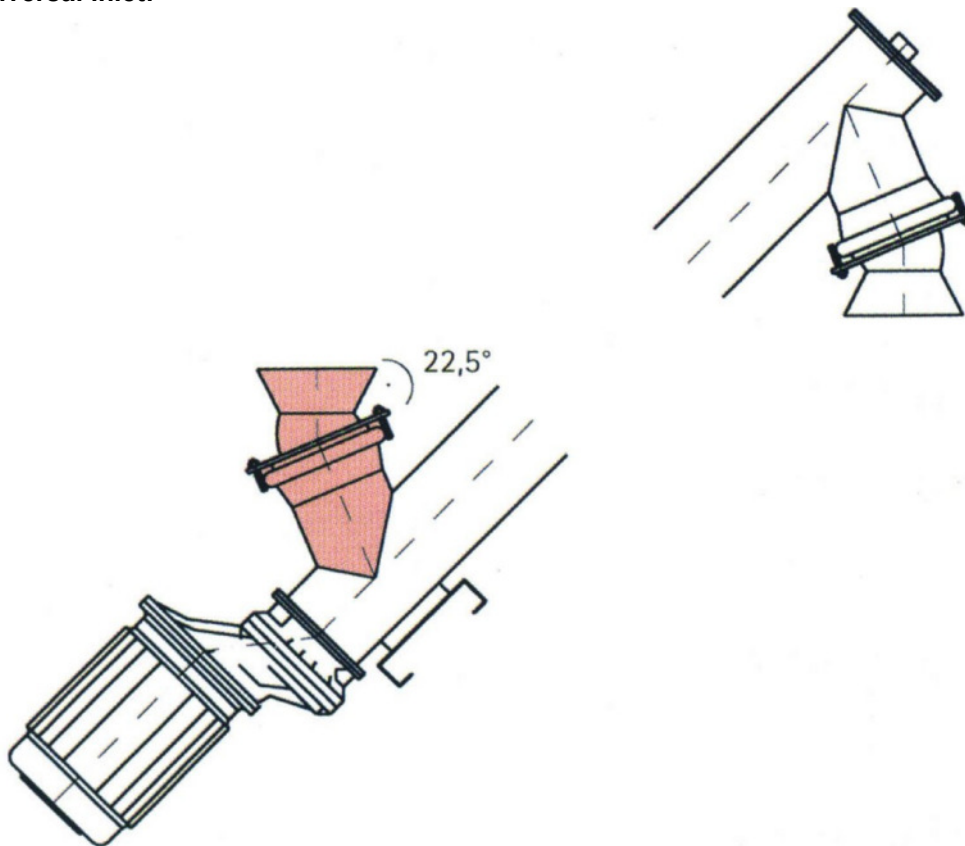

The universal inlet for inclination and dislocation adjustment simplifies installation and compensates for inaccuracies.



Bearing plate



Middle bearing



Geared motor



Automatic lubricator



Universal inlet

Standard translations

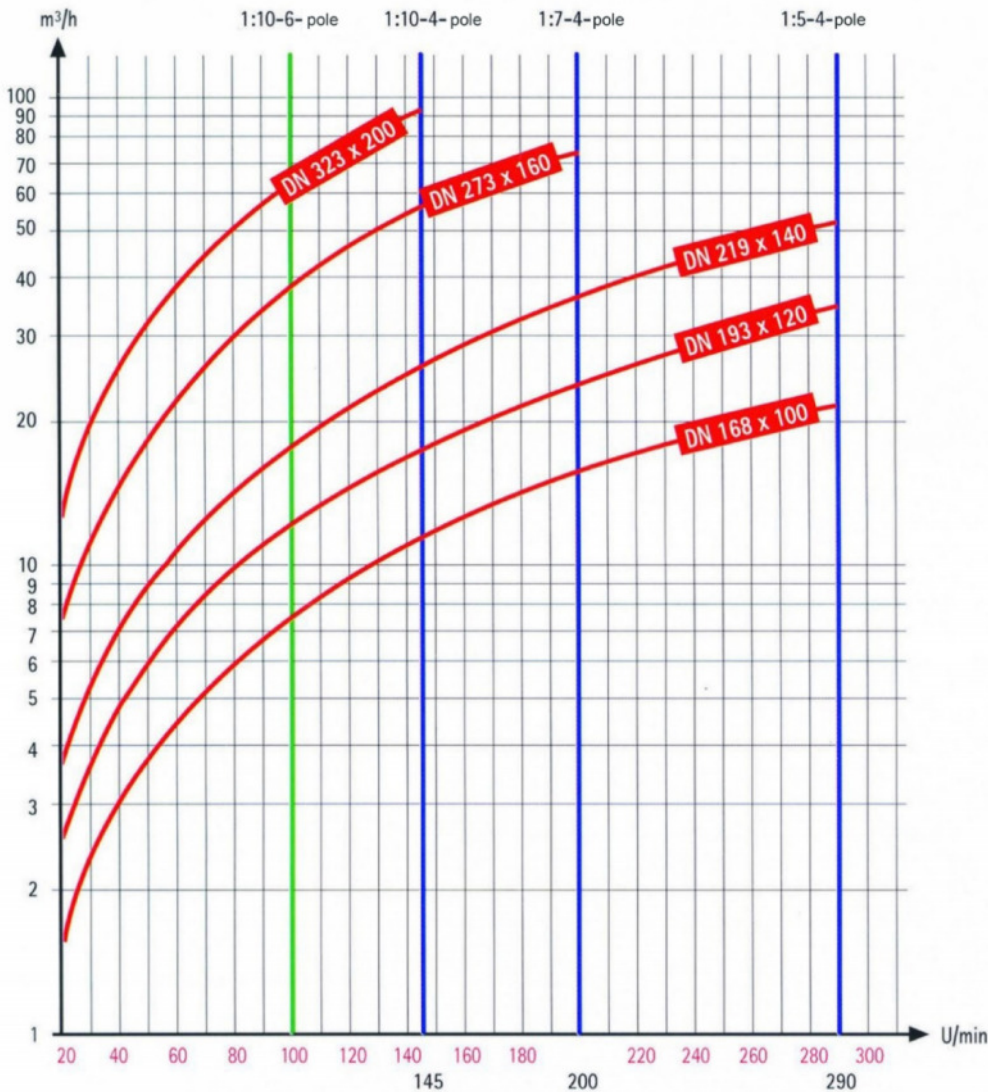

Two gear unit types and 4-pole motors are available for optimum design from 2.2 - 22 kW to choose from. At reduced speed and power throughput, weaker motors, as shown in the table, are used. Optionally available for reduction of the speed 6-pole motors and special gears are available.

Conveyor screws with a standard helix pitch tend to shoot through, depending on the flow behaviour of the material and a pitch of less than 10°. It is also possible that the pumped medium may run after the screw has come to a standstill.

We recommend the installation of overtravel flaps at the screw outlet !

Standard helical pitch progressive

Diameters, \varnothing (mm)	168	193	219	273	323
Spiral pitch in the inlet area, (mm)	100	120	140	160	200
Continuing Progressive, (mm)	150	170	200	250	300

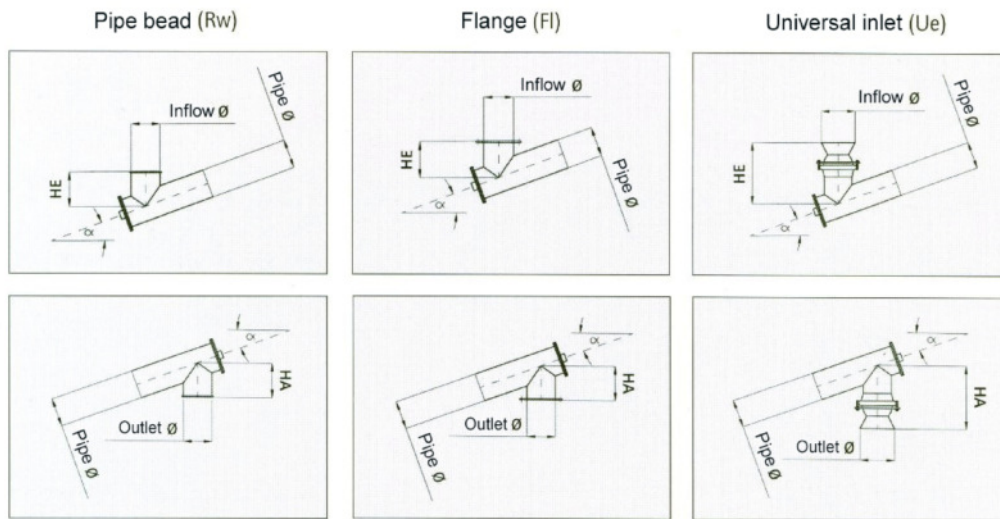

Standard input and outlets

Outlets must not be smaller in diameter than the screw pipe diameter.
Tolerance ± 1 degree for installation angle.
Height data HE + HA ± 10 mm

Screw pipe diameter in mm	Inlet / Outlet diameter in mm	Height data HE/HA in mm													
		0° - 15°		16° - 25°		26° - 30°		31° - 35°		36° - 40°		41° - 45°		22,5°	Inlet/Outlet diameter
		Fl	Rw	Fl	Rw	Fl	Rw	Fl	Rw	Fl	Rw	Fl	Rw	Ue	
168	168	175	175	175	175	175	175	225	225	225	225	250	250	425	273
	193	175	175	195	195	195	195	245	245	245	245	245	245	-	-
	219	175	175	175	175	175	225	225	225	365	365	365	365	425	273
	273	325	375	325	375	325	375	325	375	325	375	325	375	500	323
	323	325	375	325	375	325	375	325	375	325	375	325	375	500	323
193	193	175	175	175	175	225	225	275	275	275	275	275	275	-	-
	219	175	175	175	175	225	225	365	365	365	365	365	365	425	273
	273	250	300	250	300	250	300	300	300	300	300	300	300	500	323
	323	290	340	290	340	290	340	290	340	340	340	340	340	500	323
219	219	205	205	255	255	255	255	395	395	395	395	395	395	425	273
	273	220	220	220	220	270	270	370	370	370	370	370	370	500	323
	323	320	370	320	370	320	370	320	370	370	370	370	370	500	323
273	273	250	250	250	250	300	300	400	400	400	400	400	400	500	323
	323	265	265	325	325	325	325	425	425	425	425	425	425	500	323
	356	300	300	300	300	300	300	300	300	300	300	300	300	-	-
323	323	300	300	300	300	360	360	360	360	460	460	460	460	500	323
	356	310	310	360	360	360	360	360	360	460	460	460	460	-	-

Standard connection flange

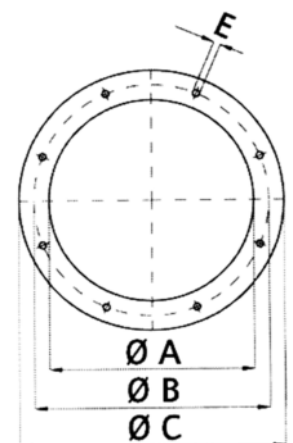

DN	150	175	200	250	300	350
A (mm)	170	195	221	275	325	358
B (mm)	200	250	250	300	350	400
C (mm)	228	278	278	328	378	440
E Ø (mm)	14	14	14	14	14	14
n°	4	4	4	8	8	8
S* (mm)	6	6	6	6	6	8

S* = Blade thickness, n° = Number of holes

Special connection pipe + flanges according to customer requirements

Available
as an option

- Pole-changing motors
- Frequency controlled motors
- Motors with PTC thermistor monitoring
- standstill monitors
- Motor make according to customer requirements
- Lateral geared motors with chain drive
- Bearing design for media temperatures above 80°C
- Automatic lubricator
- Inlet and outlet spigots with special flange or in rectangular design

Diameters	Ø 168	Ø193	Ø 219	Ø 273	Ø 323
max. conveying capacity	22 m ³ /h	35 m ³ /h	52 m ³ /h	75 m ³ /h	92 m ³ /h
Motor drive power up to a screw pitch of max. 45°					
1	3kW	4kW	5,5kW	7,5kW	7,5kW
2					9,2kW
3	4kW	5,5kW	7,5kW	9,2kW	11kW
4					15kW
5					18,5kW
6	5,5kW	7,5kW	9,2kW	11kW	22kW
7					15kW
8	7,5kW	9,2kW	11kW	18,5kW	22kW
9					15kW
10					18,5kW
11	9,2kW	11kW	18,5kW	22kW	22kW
12					22kW

Drive power of the
screw conveyors

The table values refer to cement with a medium bulk density of 1.15 t/m³, with uniform material entry into the screw conveyor.
The drive ratings refer to 4-pole electric motors according to IEC standard (design B5).
The output can be reduced proportionally by up to 10% depending on the screw pitch and the pumped medium.
Table values without guarantee.

Dimensions table tubular screw conveyor

Screw diameter	168	193	219	273	323
A (mm)	40	40	40	40	40
Ø B (mm)	according to customer requirements see inlets and outlets				
C (mm)	140	150	160	180	220
Ø D (mm)	according to customer requirements see inlets and outlets				
E (mm)	140	150	160	180	220
L	according to customer requirements				
HE	according to customer requirements see inlets and outlets				
HA	according to customer requirements see inlets and outlets				
α	0 – 45° according to customer requirements				
M	L + C + E				

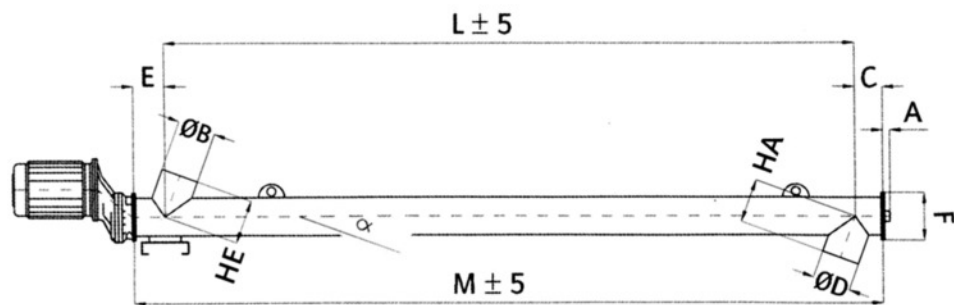

Installation dimensions geared motor U 2.1

Power in kW	2,2	3	4	5,5	7,5	9,2	11
O (mm)	222	222	222	222	222	222	222
P* (mm)	298	298	325	358	399	476	476
S (mm)	150	150	150	150	150	150	150
R (mm)	158	158	158	158	158	158	158
Q (mm)	125	125	125	150	150	175	175

Table values without guarantee
Subject to technical changes

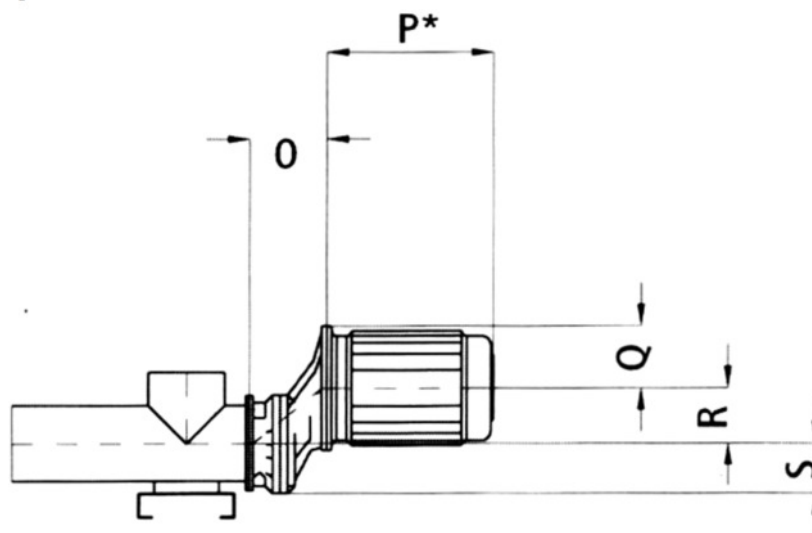

* Different according to make

Installation dimensions geared motor U 3.1

Power in kW (mm)	4	5,5	7,5	9,2	11	15	18,5	22
O (mm)	268	268	268	268	268	268	268	268
P* (mm)	325	358	399	476	476	476	519	519
S (mm)	205	205	205	205	205	205	205	205
R (mm)	200	200	200	200	200	200	200	200
Q (mm)	125	150	150	175	175	175	175	175

Ground for 4-pole motors

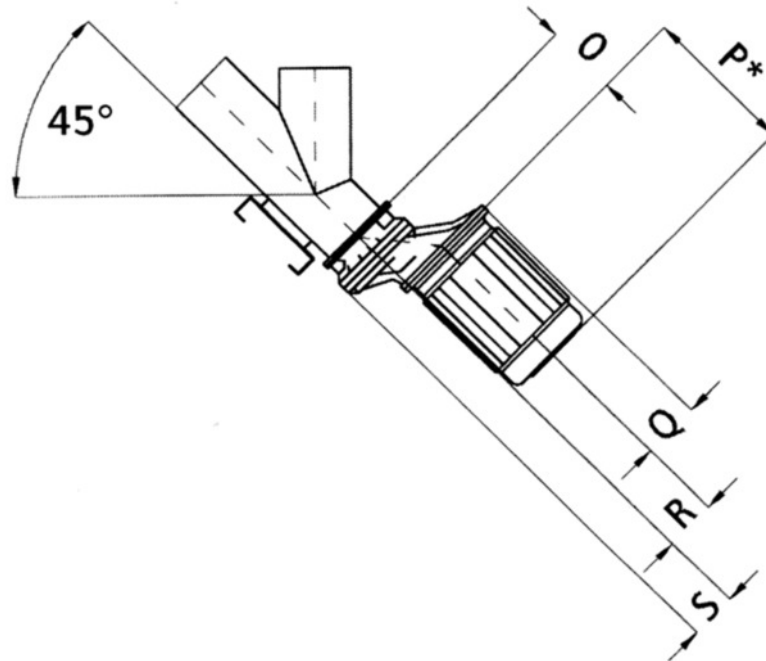

**FOR THE EFFICIENT DOSING OF BULK GOODS OF ALL KINDS
FROM SILOS AND BUNKERS**

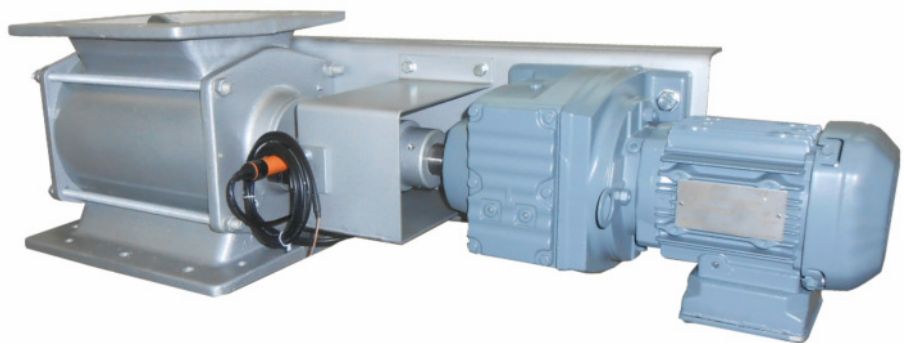

- The STANELLE rotary valve is robustly special designed for use conveying and dosing of solid products.
- Different cellular wheels, combined with an adapted number of revolutions, enable a fine graduation of through flow.

Areas of Application

- The rotary valve is built upon large dimensioned and permanently greased roller bearings, which are sealed by shaft sealing.
- The rotary valve guarantees perfect closing, due to closed and accurate design of casing and valves.

Details / Explanation

- Body and bearing cap: Cast iron
- Cellular wheel: Steel, partially with vulkollan strips

- Rust removal: SA 2,5
Primer: 2K; 40µm
Top coat: 2K; 40µm; RAL 9006
different colours on request

Finish

Dimension Drawing Cellular Wheel Sluice

Type	A 200/0,6	A 200/1,8	A 200/3,2	A 200/4,3	A 300/7,4	A 300/11,4	A 300/13	A 350/18	A 350/24
Total height (mm)	300	300	300	300	420	420	420	480	480
Total length (mm)	520	520	520	520	595	595	595	690	690
Total width (mm)	310	310	310	310	410	410	410	410	410
Inlet (mm x mm)	200 X 200	200 X 200	200 X 200	200 X 200	300 x 300	300 x 300	300 x 300	350 x 350	350 x 350
Volume flow per rotation (l)	0,6	1,8	3,2	4,3	7,4	11,4	13	18	24
Theoretical volume flow for regarding 25 Upm (m ³ / h)	1,0	3,5	6,0	7,5	12	18	20	25	35

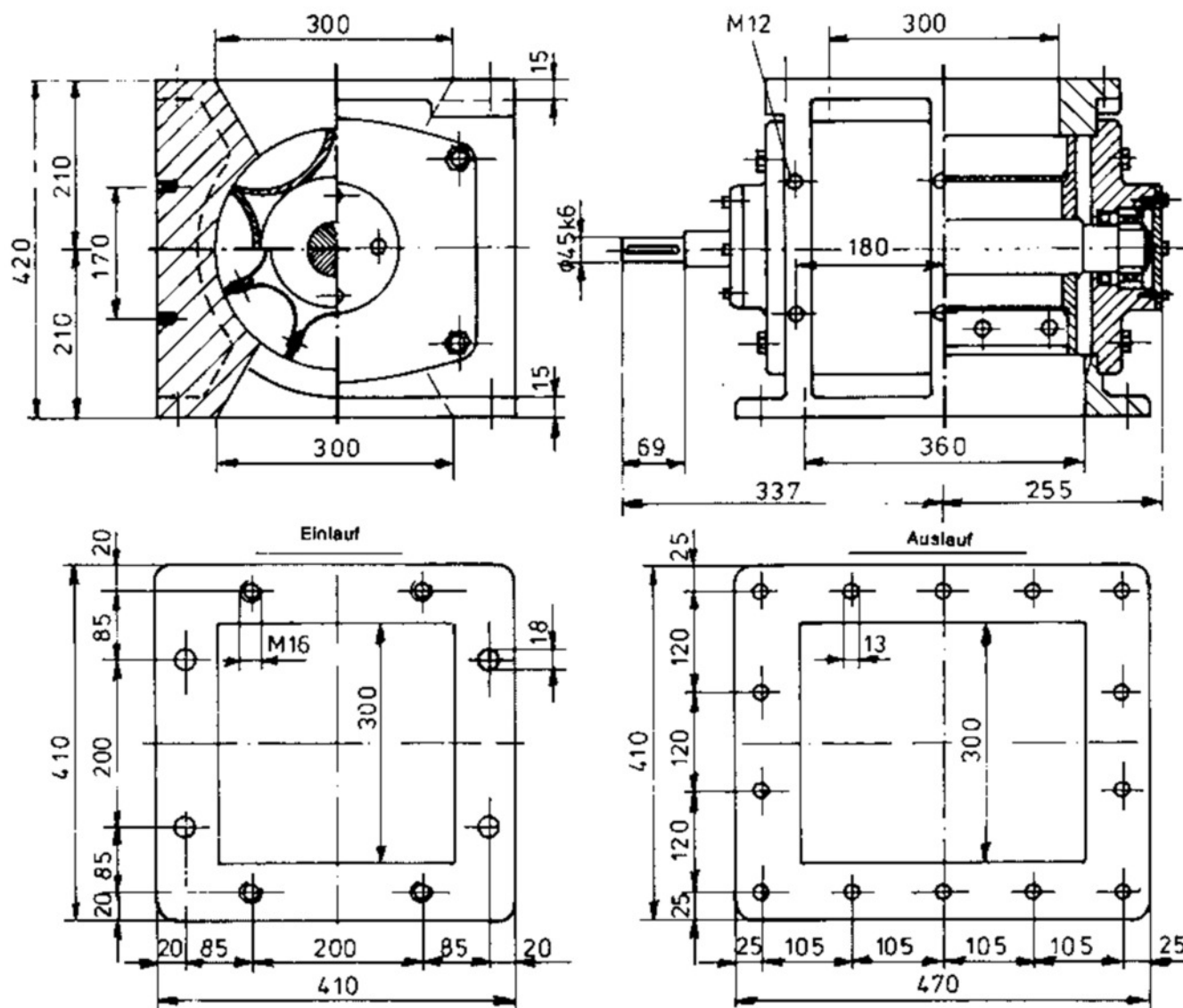

Article number

Type	A 200/0,6	A 200/1,8	A 200/3,2	A 200/4,3	A 300/7,4	A 300/11,4	A 300/13	A 350/18	A 350/24
Article number	on request								

Mobile BIG-BAG – filling station SBB 1000 M



The mobile BIG-BAG filling station SBB 1000 M can be used wherever a BIG-BAG filling station via an existing loading system, e.g. STANELLE JET LOADER RONDO/QUADRO is present.

Application

- **Mobil:**
The filling station can be easily moved with a forklift on-site
- **Multiple use RONDO/QUADRO:**
The existing STANELLE jet loaders RONDO/QUADRO normally for open and closed truck loading can also be used for BIG-BAG loading. An adaptation to existing loading systems is also available as an option.
- **Flexible:**
Perfect height adjustment due to two trapezoidal screws enable:
a) the filling of BIG-BAG´s with filling heights up 1.550 mm / optional 2.000 mm
b) the adaptation to different filling hose length depending on the BIG-BAG manufacturer
BIG-BAG´s up to 1400 x 1360 mm ground size fit into our SBB 1000 M.
- **Environmentally friendly:**
The filling-dome has an aspiration outlet to connect to central dust extraction.

Details / design

Optionally, a version with a direct filter mounting BELFI with on-site material can be adapted.

- **Continuous loading process:**
The implemented vacuum valve ensures an unwanted contraction of BIG-BAG and / or below.
- **Weighing unit:**
The weighing table is completely decoupled from the previous inflatable sleeve and butterfly valve and therefore a maximum weighing accuracy can be achieved.
- **Reliability / quality:**
STANELLE quality - ruggedized by perfect-engineered durable components.
- **Option / modifications**
Our own construction department is able to do individual adaptations / changes any time.
- **Steel Material:**
 - De-rust: SA 2,5
 - primer: 2K; EP; 40µm
 - finish paint: 2K; RAL 9006; 40µm
- **Stainless Steel :**
Glass beads blasted

Details / Design

Finish

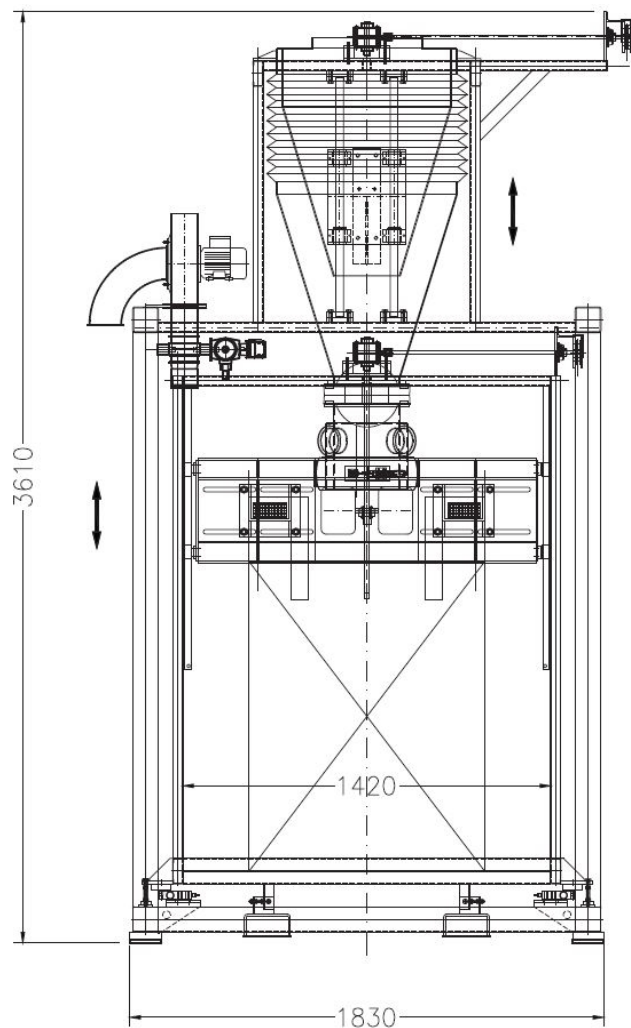

Technical Data

Frame: profil tube 100 mm x 100 mm with forklift shoes
 Filling connection: designed for JET-LOADER type QUADRO
 Vacuum valve: for ventilating the BIG-BAG station
 Vent Pipe: DN 100 with cover

Bellows: to compensate the height adjustment

Suspension: adjustment for BIG-BAG in height
 Connection device: for BIG-BAG with bulking and counter-cuff
 BIG-BAG height adjustment: manual rack winch
 Neck size inflatable sleeve: Ø 350 mm
 Butterfly valve (Loading): NW 250 electro pneumatic operated
 Weighing platform: suitable for pallet size 1200 mm x 1200 mm

BIG-BAG

BIG-BAG size: to Max. B X T max. 1200 mm x 1200 mm
 BIG-BAG height: without loops 1500 mm / optional 2000 mm
 BIG-BAG weight: max. 2000 kg
 BIG-BAG loop length: 330 - 350 mm (recommendation)
 Length of filling nozzle: mind. 350mm
 Size of filling nozzle: Ø 350 mm
 Transport: with pallet and a forklift
 Alternative: with a forklift and BIG-BAG loops

Load cells: 4 x 1.000 kg
 Weighing terminal: power supply 24VDC
 4 digital inputs and outputs
 RS-485 interface
 temperature range -20°C up to +50°C

Air blower: perfect filling of inliner BIG-BAG's
 power supply air blower
 400V/50 Hz, 0,37 kW

Control unit: standard control unit for inflatable sleeve, weighing
 terminal, air blower and potential free contacts
 400VAC/16A

Optional: filling sensor for BIG-BAG

Article number

BIG-BAG FILLING STATION SBB 1000 M	
	Article number
Design normal steel S235JR Mobile BIG-BAG filling station incl. control, weighing system, blow up clamp, butterfly valve, air blower	756 10 001
Product contact parts in stainless steel Mobile BIG-BAG filling station ATEX Zone 21, filling sensor, blow up clamp, butterfly valve	756 10 002

Bagemptying station SSA-10



The Stanelle bagemptying station SSA-10 consists of a stable robust steel construction with access door and sensor, inserted safetygrid, signal lamp, integrated suction filter system and filter control FST. The bag infeed is especially designed for low-dust bag emptying and provides the best possible operator protection. A guided air flow keeps the dust away from the operator and guides it directly into the filter. Depending on the process specification, product can be returned to the process container or to a collection container.

Areas of Application

Options:

- Bag tray for depositing the container
 - Empty bag ejection
 - Material: stainless steel 1.4301 / 1.4571
-
- Rust removal: SA 2,5
 - Primer: 2K; 40µm
 - Top coat: 2K; RAL 9006; 40µm

Details / Explanation

Finish

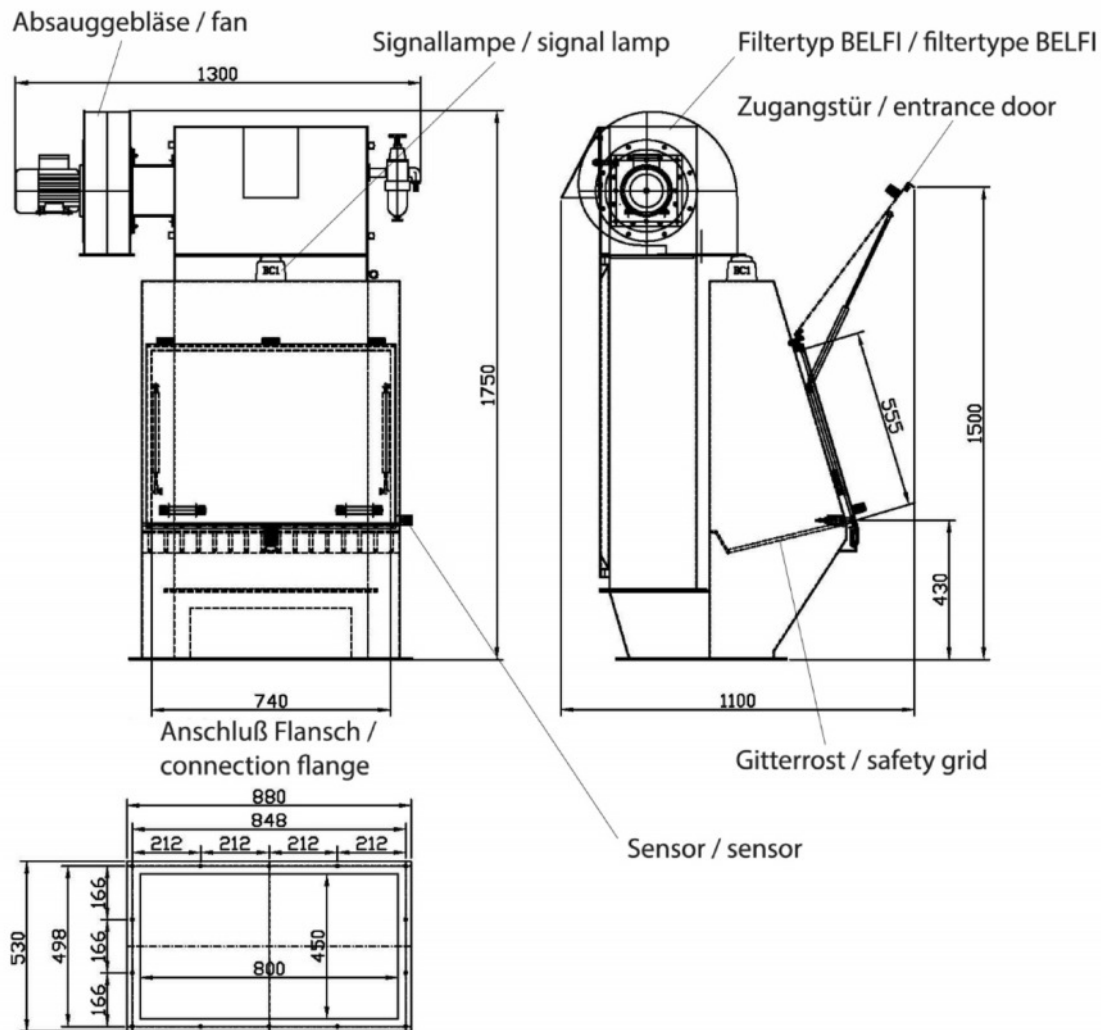

Dimensions

Bagemptying station SSA-10	
Width	1300
Height	1750
Depth	1100

Technical data bagemptying station SSA-10

Bagemptying station / SSA-10	
Opening sack chute	740 x 555 mm
Sensor	24V DC
Signal lamp	24V DC
Filter	Belfi 10, motor 230/400 V, 50 Hz
Total weight	165 kg





Technical data Belfi

Model	10
Capacity Nm ³ /h	500
Maximum temperature	120° C
Filter cartridges / pcs.	3 - 24V / DC
Filter medium	polyester
Solenoid valves / pcs.	3
Operating pressure	2,5 bar
Air connection / mm	ø 12
Actuation air	75 Nltr/min. with a break time of 20 sec.
Weight, kg	85

Article number

	Bagemptying station SSA-10
Bagemptying station SSA-10 prepared for filter Belfi 10	757 10 001
	751 10 002 (1.4301)
	751 10 002 (1.4571)
Filter Belfi 10	722 10 338
	702 10 338-06 (1.4301)
	702 10 338-11 (1.4571)

Equipment

Clock control for Belfi	Article number	
Control unit FST 3-4 Supply voltage 230V/AC Standard	881 10 206	
Control unit FST 3-4 Supply voltage 24V/DC Standard	881 10 240	
Filter control FST 3-4 Supply voltage 24V ATEX Zone 22 	881 10 265	

FOR STORAGE OF CEMENT AND OTHER DRY BULK MATERIALS



**Standard silos
in factory-welded
design**

The aggregate and cement silo in proven STANELLE quality made of steel sheet for the storage of cement and other dry bulk materials with a maximum bulk density of 1400 kg/m³.

As far as transport permits, the silos are manufactured in one piece and welded tightly. Equipped with loading and transport eyes, inspection opening NW 500, as well as welding frame or welding opening for a Stanelle type SDAK 150 overpressure/vacuum flap in the silo roof and on the silo cylinder a filling line DN100, up to height outlet flange, hot-dip galvanised, with fixed coupling type A and a STANELLE filling bend type FLOW BOW®.

The basic equipment includes a crushing cone inside the cone and a water-repellent ring outside the cone.

The substructure consists of 4 tubular steel supports, with all necessary bandages, Head and base plates as well as anchor screws. The height of outlet flange is approx. 1.500mm above foundation. Anchor bars must be provided and concreted in by the customer. All screws are hot-dip galvanized, anchor screws black.

Standard types with different diameters and volumes are available. In addition, we also offer other diameters and silo sizes according to customer requirements. The standard cone angle is 53°. For difficult to discharge media, steeper cone inclinations must be used and the discharge of the bulk material must be supported by special discharge aids, e.g. Stanelle LUALO air looseners or ASK1xxx discharge vibrating basket. As accessories we offer various prescribed and necessary accessories such as filling pipes, fixed ladders, roof edge railings, overpressure dampers, filters, level probes and discharge aids.

The corrosion protection on the outside of the standard types consists of rust removal by blasting, degree of rust removal SA 1 and a 2-component universal primer. Optionally, we also supply rust removal up to SA 2.5 and exterior paintwork with 2-component top coat in various RAL colours as well as interior paintwork and special paintwork.

Areas of Application

Details / design

Surface treatment

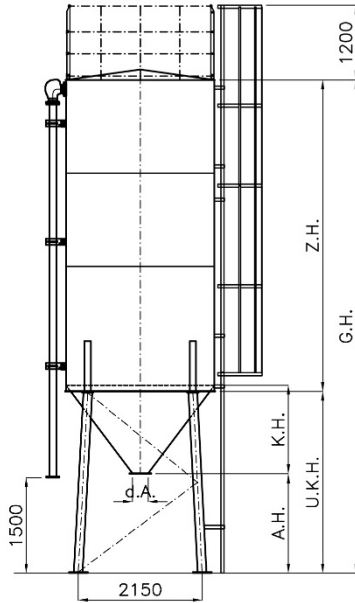

CEMENT-SILO Ø 2400

Volume m ³	U.K.H. mm	Z.H. mm	G.H. mm	G.G. kg		d.A. mm	A.H. mm	K.H. mm
24	2750	5010	7760	1800		200	1395	1455
33	2750	7010	9760	2200		250	1430	1420
39	2750	8410	11160	2600		300	1465	1385
						350	1495	1355
						400	1530	1320

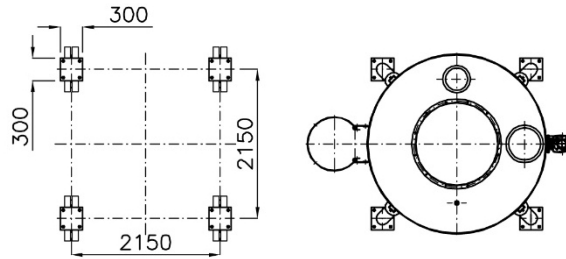

d.A. = Diameter outlet
A.H. = Discharge height
K.H. = Cone height

U.K.H. = Substructure height
Z.H. = Cylinder height
G.H. = Total height

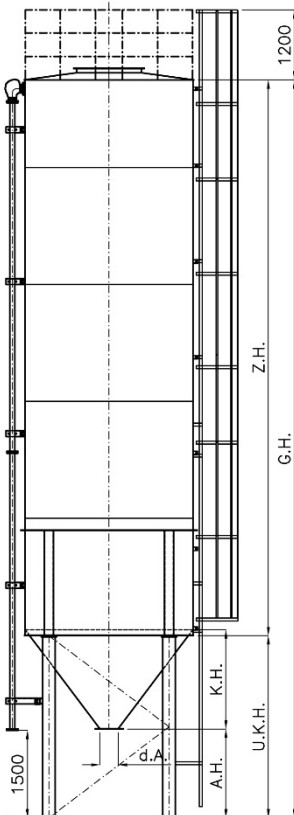

CEMENT-SILO Ø 2900

Volume m ³	U.K.H. mm	Z.H. mm	G.H. mm	G.G. kg		d.A. mm	A.H. mm	K.H. mm
32	3120	4530	7650	2150		200	1475	1775
42	3120	6030	9150	2500		250	1515	1735
48	3120	7030	10150	2650		300	1545	1705
64	3120	9530	12650	4000		350	1580	1670
80	3120	12030	15150	4900		400	1615	1635
96	3120	14530	17650	5550		500	1680	1570
						600	1745	1505
						800	1880	1370

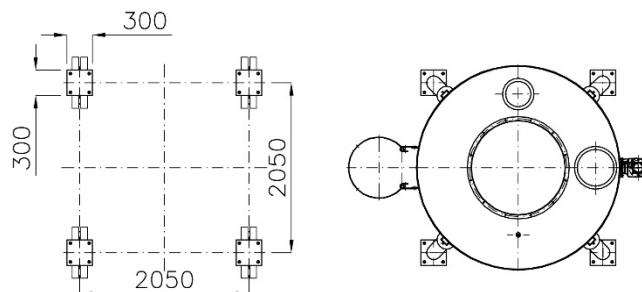

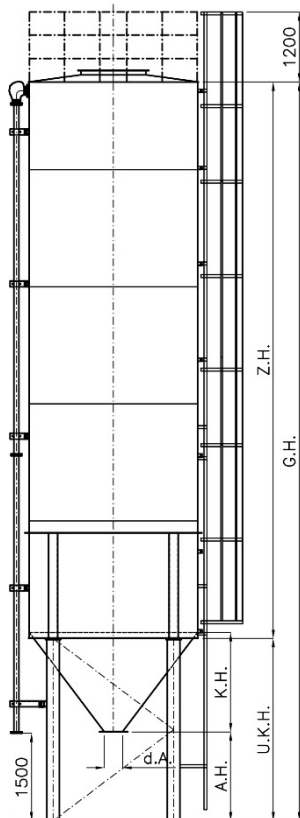

CEMENT-SILO Ø 3200

Volume m ³	U.K.H. mm	Z.H. mm	G.H. mm	G.G. kg	d.A. mm	A.H. mm	K.H. mm
55	3220	6510	9730	3350	250	1480	1950
64	3220	7510	10730	3900	300	1505	1915
80	3220	9510	12730	4700	350	1540	1880
96	3220	12010	15230	5600	400	1570	1850
128	3220	15510	18730	7800	500	1640	1780
					600	1705	1715
					800	1840	1580
					1000	1970	1450

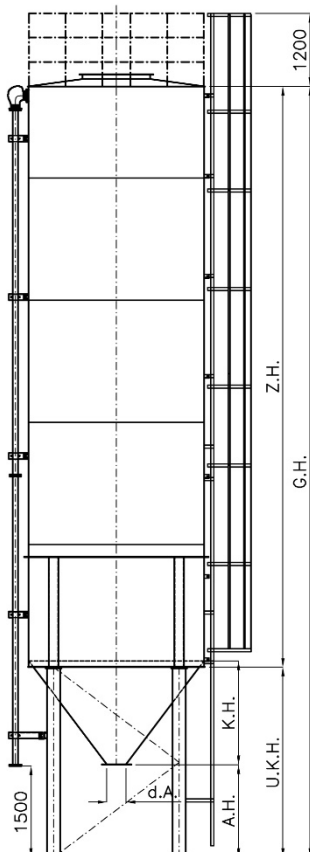
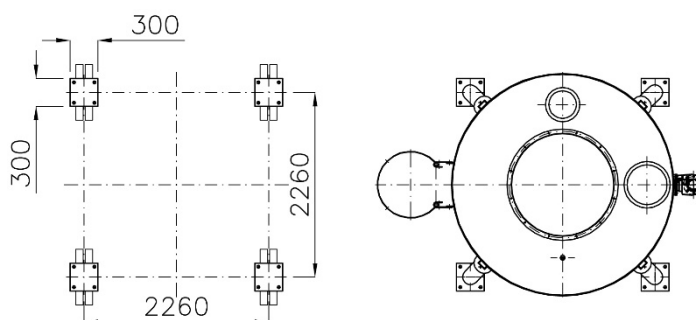

CEMENT-SILO Ø 3700

Volume m ³	U.K.H. mm	Z.H. mm	G.H. mm	G.G. kg	d.A. mm	A.H. mm	K.H. mm
70	3660	6150	9670	4500	250	1500	2460
80	3660	7010	10670	5000	300	1535	2425
102	3660	9010	12670	6000	400	1605	2355
129	3660	11510	15170	7650	500	1680	2280
156	3660	14010	17670	9300	600	1750	2210
					700	1820	2140
					800	1890	2070
					900	1960	2000

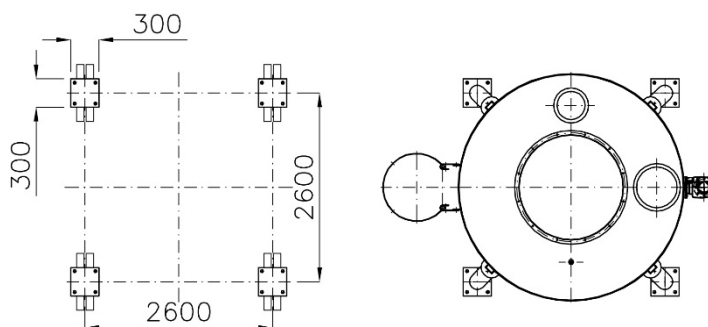

Construction of a silo

Depending on requirements, the silo consists of the following main groups:

Silo:

- 1 Roof with control opening
- 2 Steel cylinder
- 3 Cone with water-repellent ring, crushing cone and outlet flange
- 4 Substructure / clamps / support frame

Supplement:

- 21 Railing
- 22 Fixed ladder with / without resting platform
- 23 Injection nozzle
- 24 Partition wall

Components:

- 41 Overpressure/vacuum flap SDAK 150
- 42 Safety devices (e.g. overfill protection)
- 43 Filters with / without control PNEUFIX / STAFI
- 44 Level indicator Max.
- 45 Level indicator Min.
- 46 Discharge aids ASK / LUALO
- 47 Shut-off systems SMFS
- 48 Conveying system
- 49 Deflector elbow Flow-Bow[®]

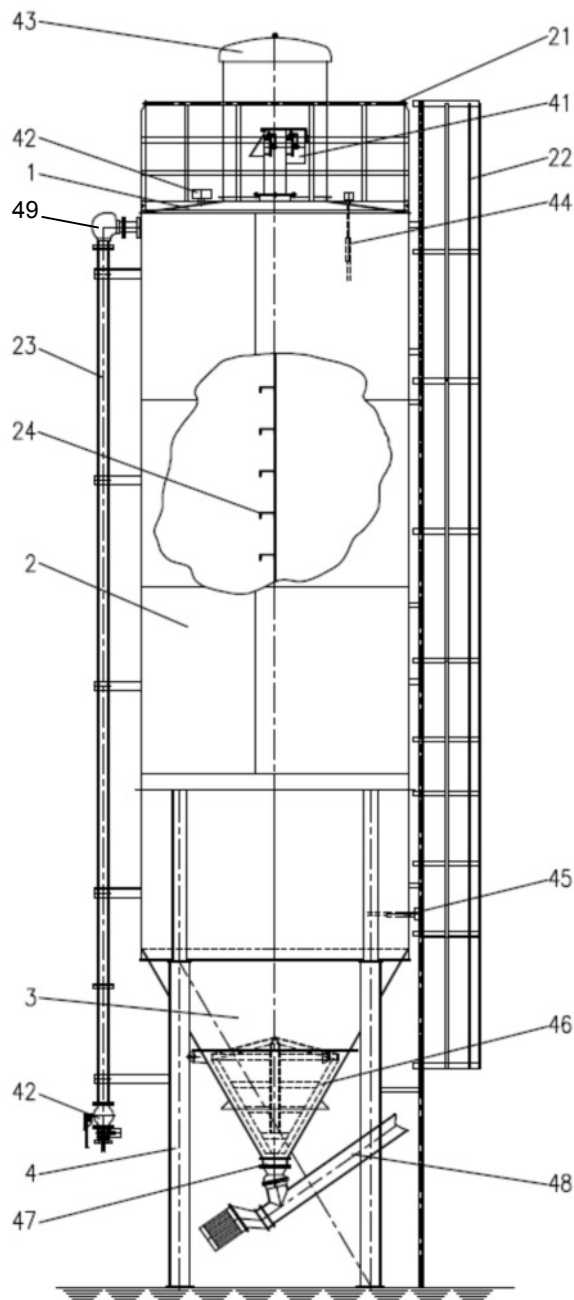

Support anchorage with 4 anchor screws (example)

$$F_{zul.} = 4 \times 35.55 \text{ kN} = 142.2 \text{ kN}$$

